

CONVERTEON™ Family

Two-Slot Chassis

AT-CV1203

Installation Guide

Copyright © 2009 Allied Telesis, Inc.

All rights reserved. No part of this publication may be reproduced without prior written permission from Allied Telesis, Inc.

Allied Telesis is a trademark of Allied Telesis, Inc. Microsoft and Internet Explorer are registered trademarks of Microsoft Corporation. Netscape Navigator is a registered trademark of Netscape Communications Corporation. All other product names, company names, logos or other designations mentioned herein are trademarks or registered trademarks of their respective owners.

Allied Telesis, Inc. reserves the right to make changes in specifications and other information contained in this document without prior written notice. The information provided herein is subject to change without notice. In no event shall Allied Telesis, Inc. be liable for any incidental, special, indirect, or consequential damages whatsoever, including but not limited to lost profits, arising out of or related to this manual or the information contained herein, even if Allied Telesis, Inc. has been advised of, known, or should have known, the possibility of such damages.

Electrical Safety and Emissions Standards

This product meets the following standards.

U.S. Federal Communications Commission

Radiated Energy

Note: This equipment has been tested and found to comply with the limits for a Class A digital device pursuant to Part 15 of FCC Rules. These limits are designed to provide reasonable protection against harmful interference when the equipment is operated in a commercial environment. This equipment generates, uses, and can radiate radio frequency energy and, if not installed and used in accordance with this instruction manual, may cause harmful interference to radio communications. Operation of this equipment in a residential area is likely to cause harmful interference in which case the user will be required to correct the interference at his own expense.

Note: Modifications or changes not expressly approved of by the manufacturer or the FCC, can void your right to operate this equipment.

Industry Canada

This Class B digital apparatus complies with Canadian ICES-003.

Cet appareil numérique de la classe A est conforme à la norme NMB-003 du Canada.

RFI Emissions FCC Class A, EN55022 Class A, EN61000-3-2, EN61000-3-3, VCCI Class A, C-TICK, CE

Warning: In a domestic environment this product may cause radio interference in which case the user may be required to take adequate measures.

Immunity EN55024

Electrical Safety EN60950 (TUV), UL 60950 (CUL_{US})



Laser Safety EN60825

Translated Safety Statements

Important: The  indicates that a translation of the safety statement is available in a PDF document titled *Translated Safety Statements* posted on the Allied Telesis website at www.alliedtelesis.com and on the documentation CD shipped with this product.

Contents

Preface	11
Safety Symbols Used in this Document	12
Where to Find Web-based Guides	13
Contacting Allied Telesis	14
Online Support	14
Email and Telephone Support	14
Returning Products	14
Sales or Corporate Information	14
Management Software Updates	14
Chapter 1: Overview	15
Features	16
Front and Back Panels	17
AT-CVMNT12 Wall-Mount Bracket	18
LEDs	19
Operations, Administration and Maintenance Features	20
Chapter 2: Installation	21
Reviewing the Safety Precautions	22
Selecting a Site for the Chassis	23
Unpacking the Chassis	24
Installing the Rubber Feet	26
Installing a Converteon Line Card	27
Grounding the Chassis	30
Powering On the Chassis	32
Verifying the Installation	35
Replacing a Line Card or the Management Card	36
Appendix A: Technical Specifications	37
Physical Specifications	37
Environmental Specifications	37
Power Specifications	37
Safety and Electromagnetic Emissions Certifications	38

Figures

Figure 1. AT-CV1203 Chassis.....	16
Figure 2. Front and Back Panels of the AT-CV1203 Chassis.....	17
Figure 3. AT-CVMNT12 Wall-Mount Bracket.....	18
Figure 4. Power LEDs	19
Figure 5. Attaching the Rubber Feet	26
Figure 6. Removing a Slot Cover.....	27
Figure 7. Alignment Guides	28
Figure 8. Inserting a Line Card	29
Figure 9. Tightening the Captive Screw.....	29
Figure 10. Stripping the Grounding Wire	30
Figure 11. Attaching the Grounding Wire to the Grounding Lug.....	30
Figure 12. Removing the Grounding Lug Screws.....	31
Figure 13. Attaching the Grounding Lug.....	31
Figure 14. Connecting the Power Adapter and Power Cord.....	32
Figure 15. Connecting the Power Cord	33
Figure 16. Securing the Power Cord with a Tie Wrap	33

Tables

Table 1. Safety Symbols 12
Table 2. Power LEDs 19
Table 3. AT-CV1203 Chassis Components 24

Preface



This guide contains the installation instructions for the Converteon AT-CV1203 Chassis. This preface contains the following sections:

- “Safety Symbols Used in this Document” on page 12
- “Where to Find Web-based Guides” on page 13
- “Contacting Allied Telesis” on page 14

Safety Symbols Used in this Document

This document uses the safety symbols defined in Table 1.

Table 1. Safety Symbols

Symbol	Meaning	Description
	Caution	Performing or omitting a specific action may result in equipment damage or loss of data.
	Warning	Performing or omitting a specific action may result in electrical shock.

Where to Find Web-based Guides

The installation and user guides for all Allied Telesis products are available in portable document format (PDF) on our web site at **www.alliedtelesis.com**. You can view the documents online or download them onto a local workstation or server.

Contacting Allied Telesis

This section provides Allied Telesis contact information for technical support as well as sales and corporate information.

Online Support

You can request technical support online by accessing the Allied Telesis Knowledge Base: www.alliedtelesis.com/support/kb.aspx. You can use the Knowledge Base to submit questions to our technical support staff and review answers to previously asked questions.

Email and Telephone Support

For Technical Support via email or telephone, refer to the Allied Telesis web site at www.alliedtelesis.com. Select your country from the list on the web site and then select the appropriate tab.

Returning Products

Products for return or repair must first be assigned a return materials authorization (RMA) number. A product sent to Allied Telesis without an RMA number will be returned to the sender at the sender's expense. For instructions on how to obtain an RMA number, go to the Support section on our web site at www.alliedtelesis.com.

Sales or Corporate Information

You can contact Allied Telesis for sales or corporate information through our web site at www.alliedtelesis.com.

Management Software Updates

New releases of the management software for our managed products are available from the following Internet sites:

- Allied Telesis web site: www.alliedtelesis.com
- Allied Telesis FTP server: <ftp://ftp.alliedtelesis.com>

If the FTP server prompts you to log on, enter "anonymous" as the user name and your email address as the password.

Chapter 1

Overview

This chapter contains the following sections:

- “Features” on page 16
- “Front and Back Panels” on page 17
- “AT-CVMNT12 Wall-Mount Bracket” on page 18
- “LEDs” on page 19
- “Operations, Administration and Maintenance Features” on page 20

Features

The AT-CV1203 Chassis is part of the Converteon product line. It is a two-slot enclosure for the Fast and Gigabit Ethernet media converter line cards and the AT-CV5M02 Management Card. The chassis is compatible with all the Converteon line cards and can accommodate two line cards, one line card and the AT-CV5M02 Management Card, or the dual-slot AT-CM70S Media Converter Line Card.

You can place the chassis on a table or desk, or mount it on the wall with the optional AT-CVMNT12 Wall-Mount Bracket.

The chassis comes with a single power adapter. A second power adapter can be added for power redundancy.

You can use the chassis and the line cards as managed or unmanaged devices. To add management, you can either install the AT-CV5M02 Management Card or use remote peer management, which is one of the Operations, Administration, and Maintenance features and which lets you manage remote line cards from their local counterparts in a managed chassis.

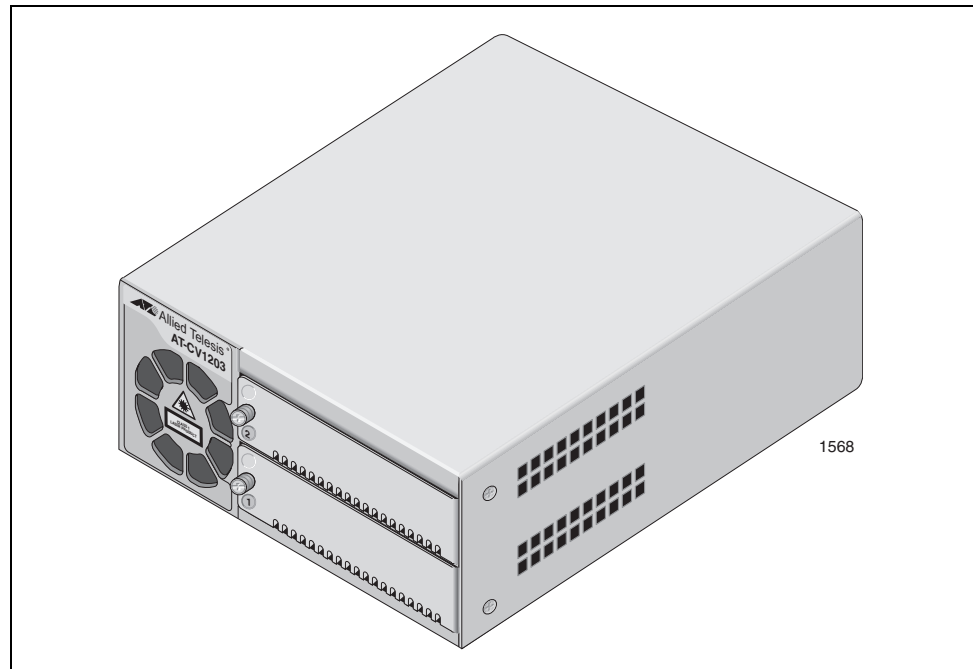

Figure 1. AT-CV1203 Chassis

Note

For the current list of the Converteon line cards, refer to the Allied Telesis web site or contact your authorized sales representative.

Front and Back Panels

Figure 2 shows the front and back panels of the AT-CV1203 Chassis.

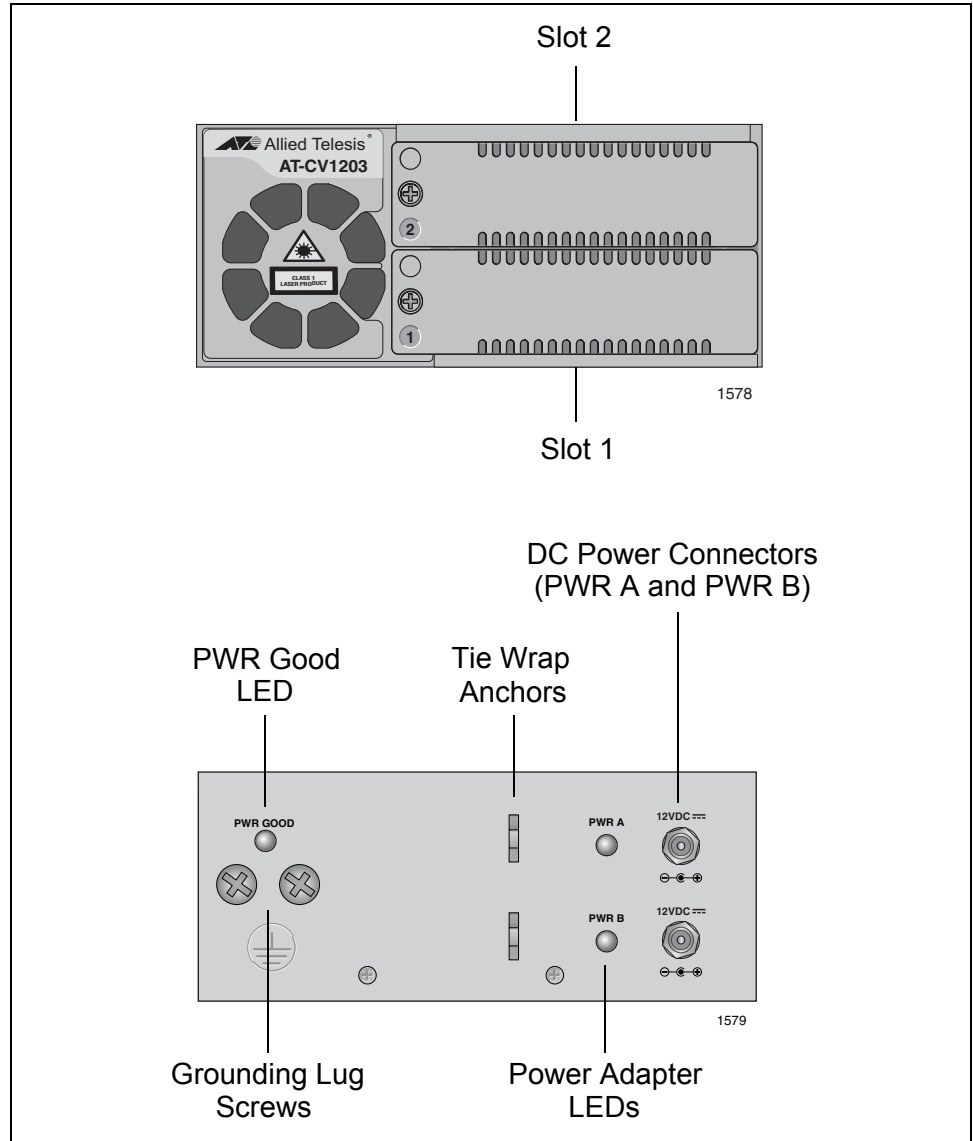

Figure 2. Front and Back Panels of the AT-CV1203 Chassis

AT-CVMNT12 Wall-Mount Bracket

The AT-CV1203 Chassis can be mounted on a wall with the optional AT-CVMNT12 Wall-Mount Bracket, shown in Figure 3. To order the bracket, contact your Allied Telesis sales representative.

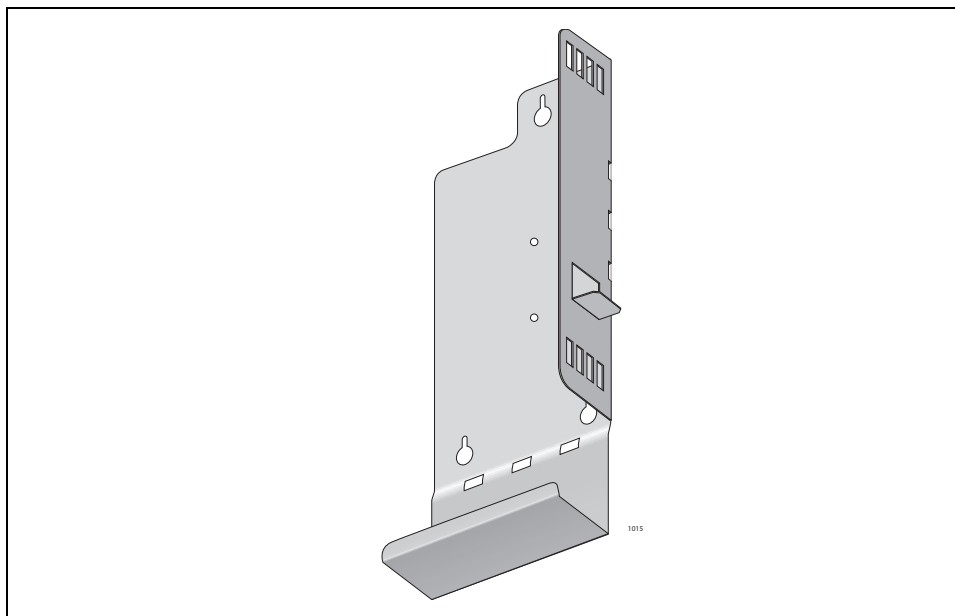

Figure 3. AT-CVMNT12 Wall-Mount Bracket

LEDs

Figure 4 identifies the power LEDs on the rear panel.

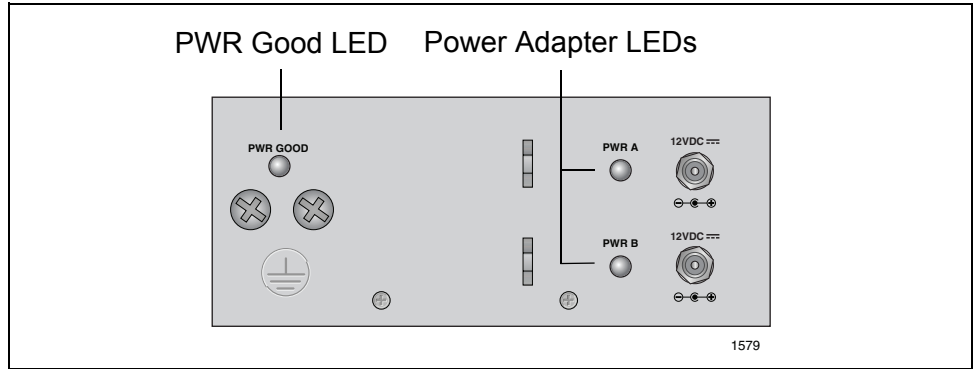

Figure 4. Power LEDs

Table 1 describes the power LEDs.

Table 1. Power LEDs

LED	State	Description
PWR GOOD	Green	The power being supplied to the line cards is within the normal operating range.
	OFF	The chassis is not receiving power or the power is outside the normal operating range.
PWR A	Green	Power adapter A is operating normally.
	OFF	Power adapter A is not receiving power, isn't present, or has failed.
PWR B	Green	Power adapter B is operating normally.
	OFF	Power adapter B is not receiving power, isn't present, or has failed.

Operations, Administration and Maintenance Features

The AT-CV1203 Chassis supports all the Operations, Administration and Maintenance (OAM) features of the managed AT-CM2 Series and AT-CM3 Series Line Cards and the AT-CM70S Line Card. The features are listed here and are fully described in the *Converteon AT-S73, AT-S99, and AT-S102 Management Software User's Guide*:

- ❑ Remote peer management - This feature lets you configure remote line cards in an unmanaged chassis through their line card counterparts in a managed chassis.
- ❑ Remote updates of the AT-S73 or AT-S102 Management Software - This feature lets you download new management software to remote AT-CM2 Series and AT-CM3 Series Line Cards from their local counterparts.
- ❑ OAM loopback tests - This feature lets you test the quality of the fiber optic cable that connects two line cards or that connects a line card to some other OAM-compliant device.
- ❑ Dying gasp and first RPS failure signals - This feature notifies you if a power supply on the AT-CV1203 Chassis loses power.
- ❑ OAM variable requests - This feature lets you send queries for the values of MIB objects on OAM-compliant devices.

If you plan to implement the dying gasp and the first RPS failure features, note the following:

- ❑ There are two versions of the AT-CV1203 Chassis. Units built after March 2009 and having "04187" or "04188" in their serial numbers support the first RPS failure signal on the AT-CM3 Series Media Converter Line Cards without the AT-CV5M02 Management Module:

Serial Number: x04187xxxxxxxxxx

Serial Number: x04188xxxxxxxxxx

- ❑ The dying gasp and first RPS failure signals will not work if the AT-CV1203 Chassis contains both an AT-CM2 Series Line Card and an AT-CM3 Series Line Card. If you plan to use these features, do not install cards from both series in the same chassis.

Chapter 2

Installation

This chapter contains the following installation procedures for the AT-CV1203 Chassis:

- “Reviewing the Safety Precautions” on page 22
- “Selecting a Site for the Chassis” on page 23
- “Unpacking the Chassis” on page 24
- “Installing the Rubber Feet” on page 26
- “Installing a Converteon Line Card” on page 27
- “Grounding the Chassis” on page 30
- “Powering On the Chassis” on page 32
- “Verifying the Installation” on page 35
- “Replacing a Line Card or the Management Card” on page 36

Note

For instructions on how to install the AT-CV1203 Chassis on a wall with the AT-CVMNT12 Wall-Mount Bracket, refer to the installation guide included with the bracket.

Reviewing the Safety Precautions

Please review the following safety precautions before you begin to install the chassis or any of its components.

Note

The  indicates that a translation of the safety statement is available in a PDF document titled *Translated Safety Statements* on the Allied Telesis website at www.alliedtelesis.com and on the documentation CD shipped with this product.





Warning: Do not work on equipment or cables during periods of lightning activity.  E2



Warning: Power cord is used as a disconnection device. To de-energize equipment, disconnect the power cord.  E3





Warning: Class I Equipment. This equipment must be earthed. The power plug must be connected to a properly wired earth ground socket outlet. An improperly wired socket outlet could place hazardous voltages on accessible metal parts.  E4

Pluggable Equipment. The socket outlet shall be installed near the equipment and shall be easily accessible.  E5



Caution: Air vents must not be blocked and must have free access to the room ambient air for cooling.  E6

Warning: Operating Temperature. This product is designed for a maximum ambient temperature of 40° degrees C.  E7

All Countries: Install product in accordance with local and National Electrical Codes.  E8



Warning: Remove all metal jewelry, such as rings and watches, before installing or removing a line card from a powered-on chassis.  E26

Selecting a Site for the Chassis

The site chosen for the unit should meet the following requirements:

- ❑ The power outlet should be close to the chassis and be easily accessible.
- ❑ The site should allow for easy access to the media converter module slots on the front panel and to the power supply connectors on the back panel.
- ❑ There should be unrestricted air flow around the vents of the chassis.
- ❑ There should not be any objects placed on top of the chassis.
- ❑ The site should be a moisture-free environment.
- ❑ The site should be a dust-free environment.
- ❑ The power sources for a chassis that has two power supplies should be located on different circuits to protect the unit from a power circuit failure.
- ❑ Dedicated power circuits or power conditioners should be used to provide reliable electrical power to the network device.
- ❑ If you are installing the chassis on a table, the table should be level and secure.
- ❑ The site should not expose the media converter chassis or the twisted pair cables to sources of electrical noise, such as radios, electric motors, transmitters, broadband amplifiers, power lines, and fluorescent fixtures.

Unpacking the Chassis

As you unpack the unit, verify that all the items listed in Table 2 are included in the shipping container. If an item is missing or damaged, contact your Allied Telesis sales representative for assistance.

Note

Store the packaging material in a safe location. You must use the original shipping material if you need to return the unit to Allied Telesis.

Table 2. AT-CV1203 Chassis Components





Component	Description
 <p>1568</p>	<p>One AT-CV1203 Chassis</p>
 <p>1569</p>	<p>One power adapter</p>
 <p>1570</p>	<p>One AC power cord with region-specific AC power connector</p>

Table 2. AT-CV1203 Chassis Components

Component	Description
 <p>Two AT-CV5PNL1 slot covers, shown as perspective views of the component. The part number 1571 is visible at the bottom right of the illustration.</p>	<p>Two pre-installed AT-CV5PNL1 slot covers</p>
 <p>Four rubber feet, shown as a perspective view of a rectangular strip with four square feet. The part number 1437 is visible at the bottom right of the illustration.</p>	<p>Four rubber feet</p>
 <p>One grounding lug, shown as a perspective view of a metal component with a threaded end and two circular holes. The part number 1409 is visible at the bottom right of the illustration.</p>	<p>One grounding lug</p>
 <p>Two tie wraps, shown as perspective views of two curved plastic straps with hook ends. The part number 1583 is visible at the bottom right of the illustration.</p>	<p>Two tie wraps</p>

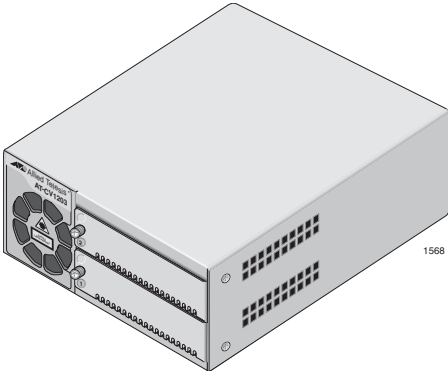
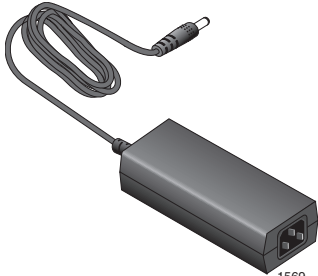
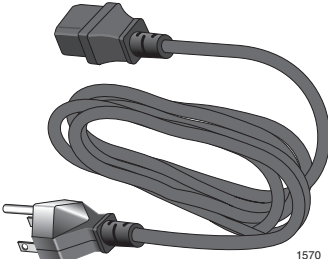
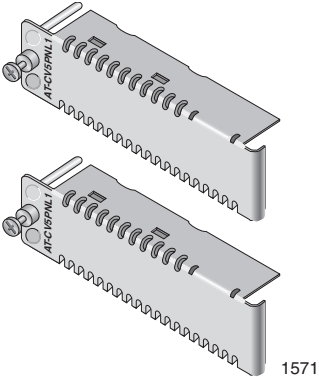
Installing the Rubber Feet

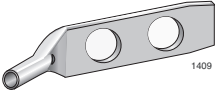
If you are installing the AT-CV1203 Chassis on a desktop, turn the unit over and attach the four rubber feet to the corners, as shown in Figure 5.

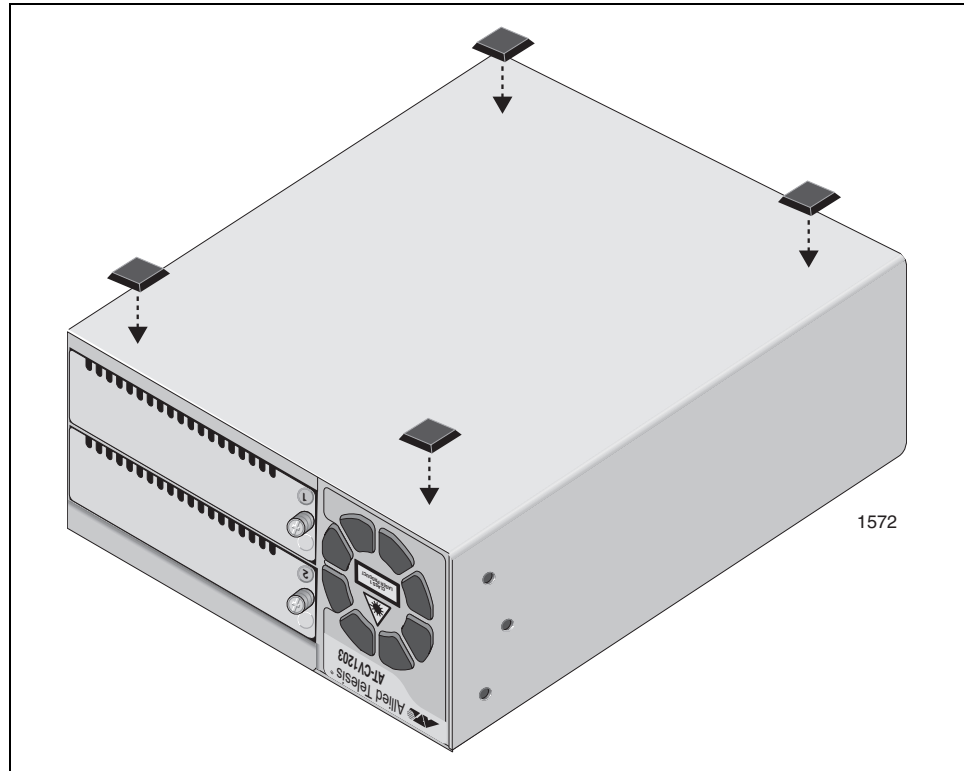

Figure 5. Attaching the Rubber Feet

Installing a Converteon Line Card

To install a Converteon media converter line card or the AT-CV5M02 Management Card in the chassis, perform the following procedure:

1. Using a Phillips-head screwdriver, loosen the captive screw on one of the AT-CV5PNL1 blank slot covers and remove the cover. The cards can be installed in either slot. If you are installing the AT-CM70S Line Card, remove the covers from both slots.

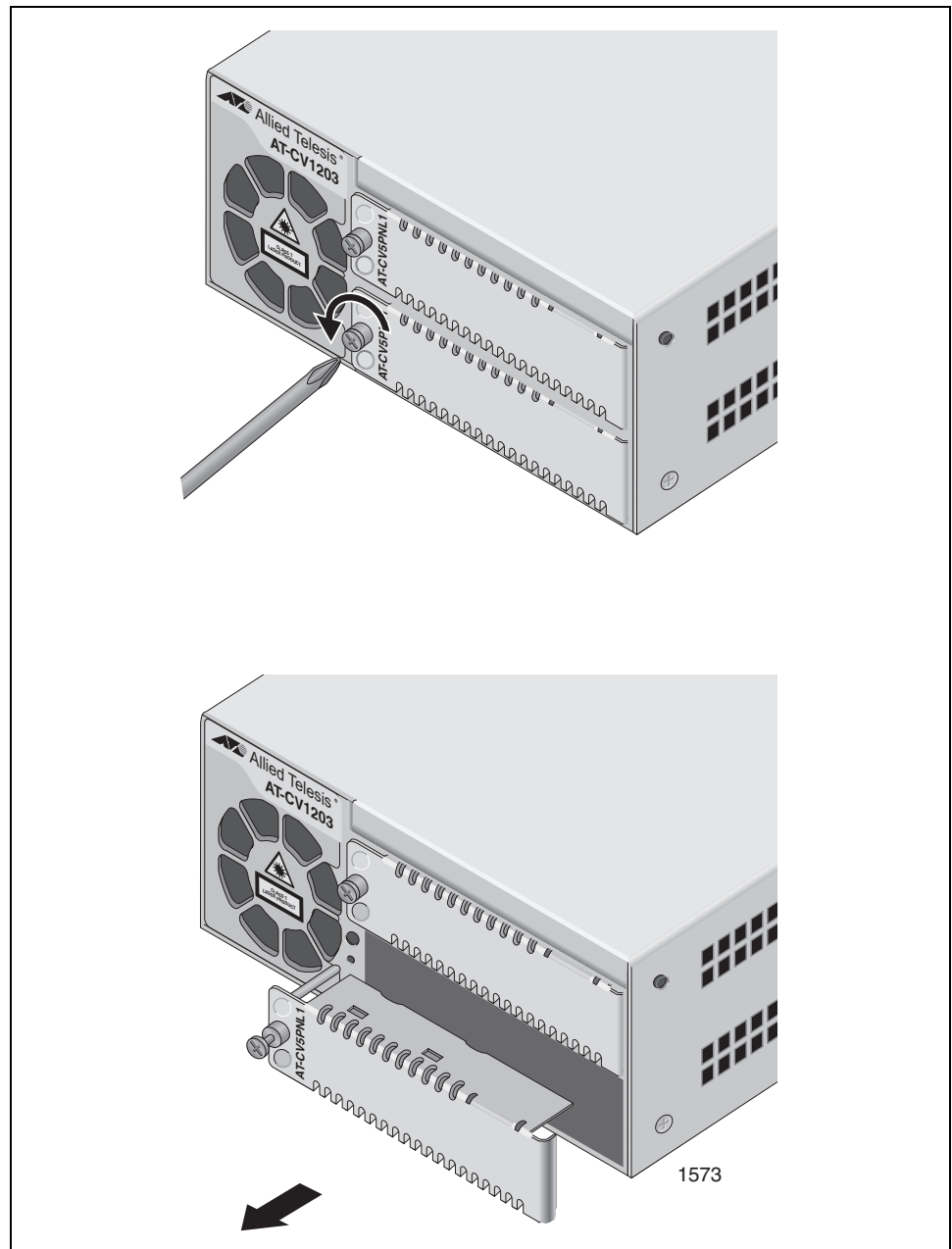

Figure 6. Removing a Slot Cover

Note

Empty slots should be kept covered. Retain the slot cover and reinstall it if you ever remove the line card without replacing it.

2. Remove the Converteon media converter line card or the AT-CV5M02 Management Card from its shipping package.

Store the package in a safe place. You must use the original package if you need to return the unit to Allied Telesis.



Caution

Be sure to observe all standard electrostatic discharge (ESD) precautions, such as wearing an antistatic wrist strap, to avoid damaging the device. Line cards can be damaged by static electricity.

3. Set the line card's DIP switches if necessary. For instructions, refer to the documentation that ships with the line card.
4. Align the edges of the line card with the left and right alignment guides located inside the slot.

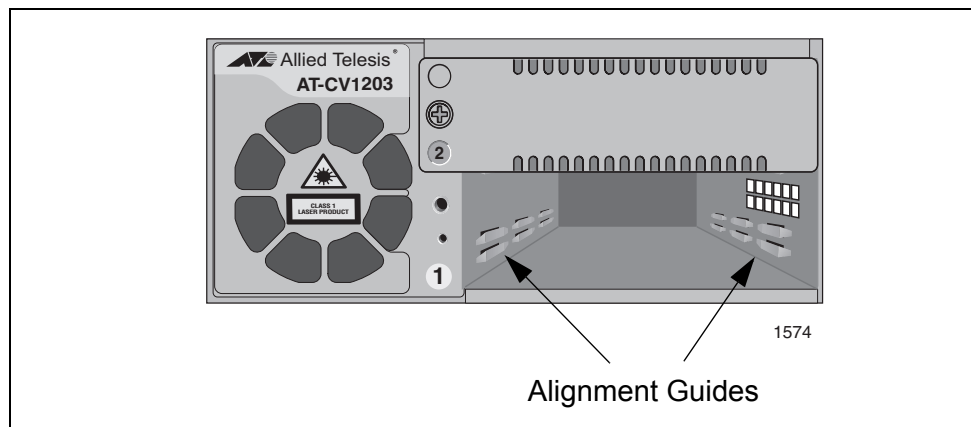

Figure 7. Alignment Guides

5. Slide the line card into the slot, as shown in Figure 8, until the front panel of the line card is flush with the front of the chassis.



Caution

Do not force the line card into place. If there is resistance, remove the card, verify that the edges of the card are properly aligned in the guides in the chassis' module slot, and reinsert it.

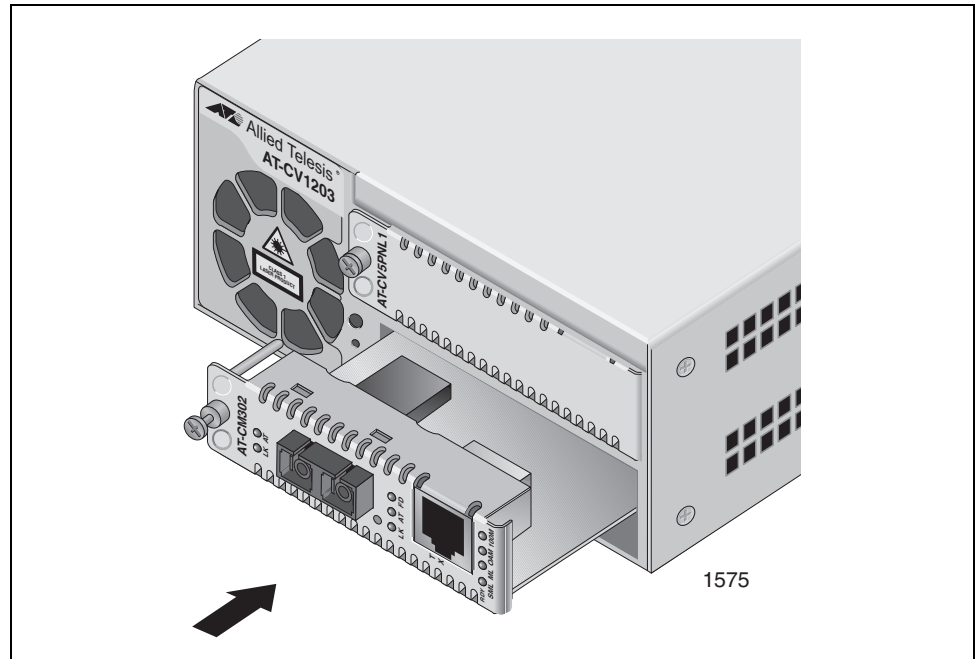

Figure 8. Inserting a Line Card

6. Use a Phillips screwdriver to tighten the captive screw on the line card, as shown in Figure 9.

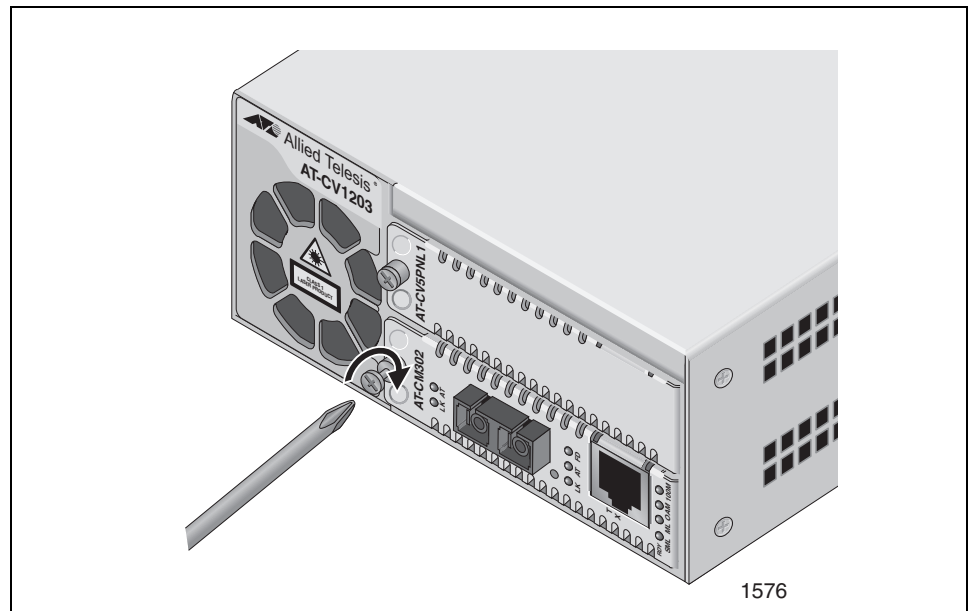

Figure 9. Tightening the Captive Screw

7. To install another card in the chassis, repeat this procedure.

For instructions on how to cable the line cards or the management card, refer to the documentation that ships with the units.

Grounding the Chassis

This procedure requires these items:

- ❑ Phillips head No. 2 screwdriver
- ❑ 10 AWG solid wire (The length of the wire will depend on your installation.)
- ❑ Crimping tool
- ❑ Grounding lug (included with the chassis)

To ground the AT-CV1203 Chassis, perform the following procedure:

1. Strip the grounding wire as shown in Figure 10.

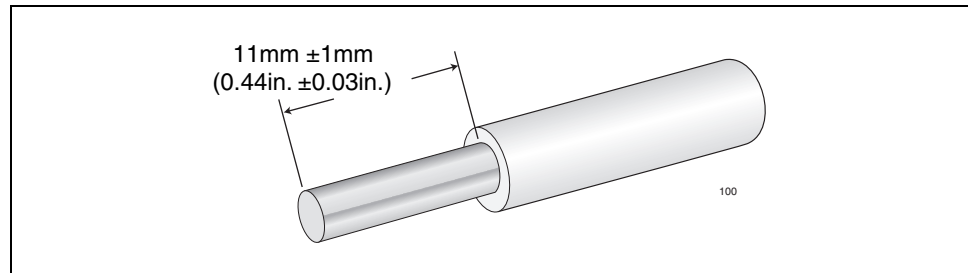

Figure 10. Stripping the Grounding Wire

2. Use a crimping tool to attach the wire to the grounding lug included with the chassis.

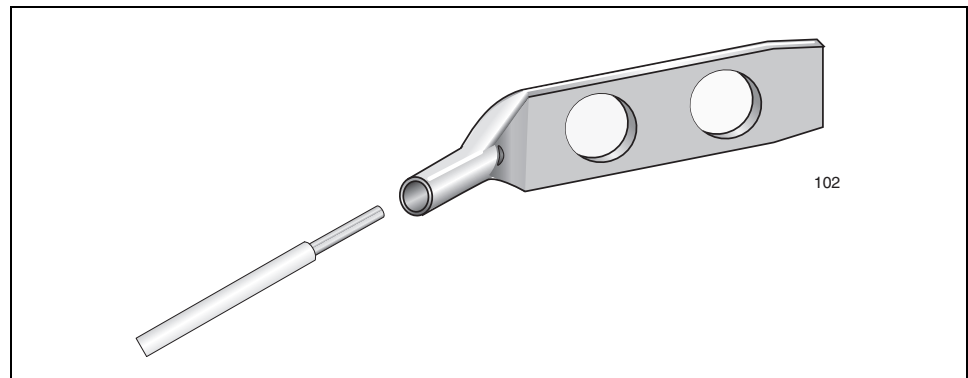

Figure 11. Attaching the Grounding Wire to the Grounding Lug

3. Remove the two grounding lug screws from the back panel of the chassis.

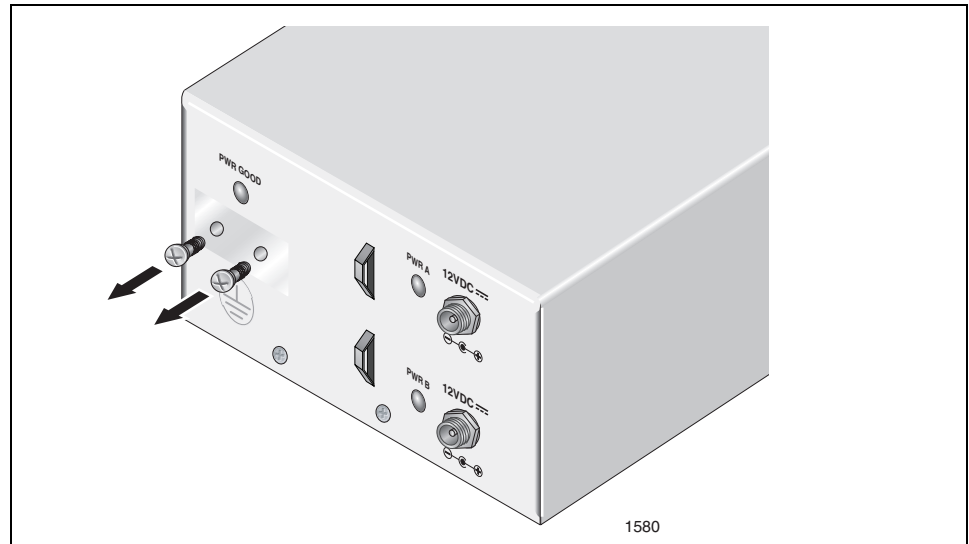

Figure 12. Removing the Grounding Lug Screws

4. Attach the grounding lug to the back panel of the chassis using the two screws removed in the previous step.

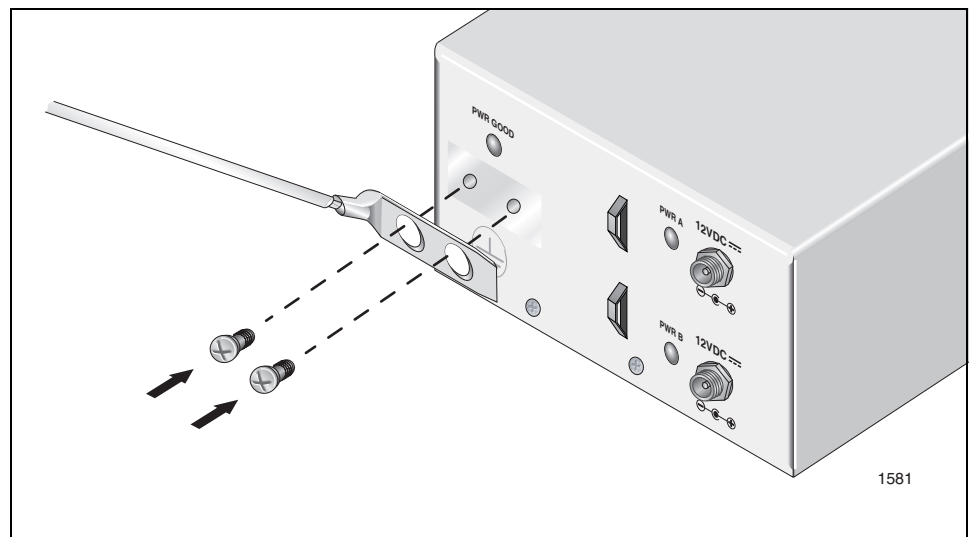

Figure 13. Attaching the Grounding Lug

5. Attach the other end of the grounding wire to an appropriate grounding point at your site.

Powering On the Chassis

Note

Use only power sources that are UL Listed (QQGQ or EPBU), TUV Licensed or other Safety Agencies approved, and that are suitable for country of use.

To power on the AT-CV1203 Chassis, perform the following procedure:

1. Connect the power cord to the power adapter, as shown in Figure 14.

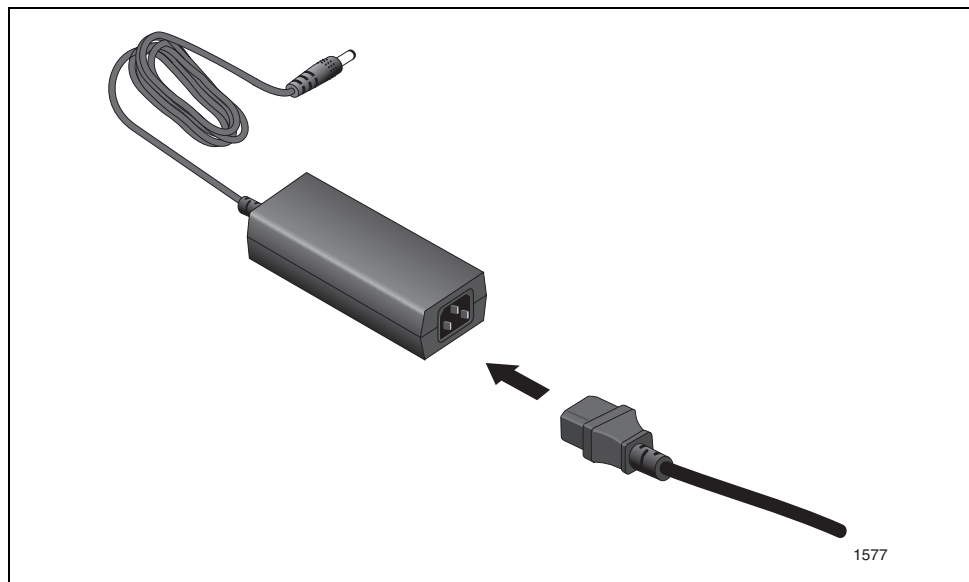

Figure 14. Connecting the Power Adapter and Power Cord

2. Plug the DC connector on the power adapter to either the PWR A or PWR B connector on the back panel of the chassis.

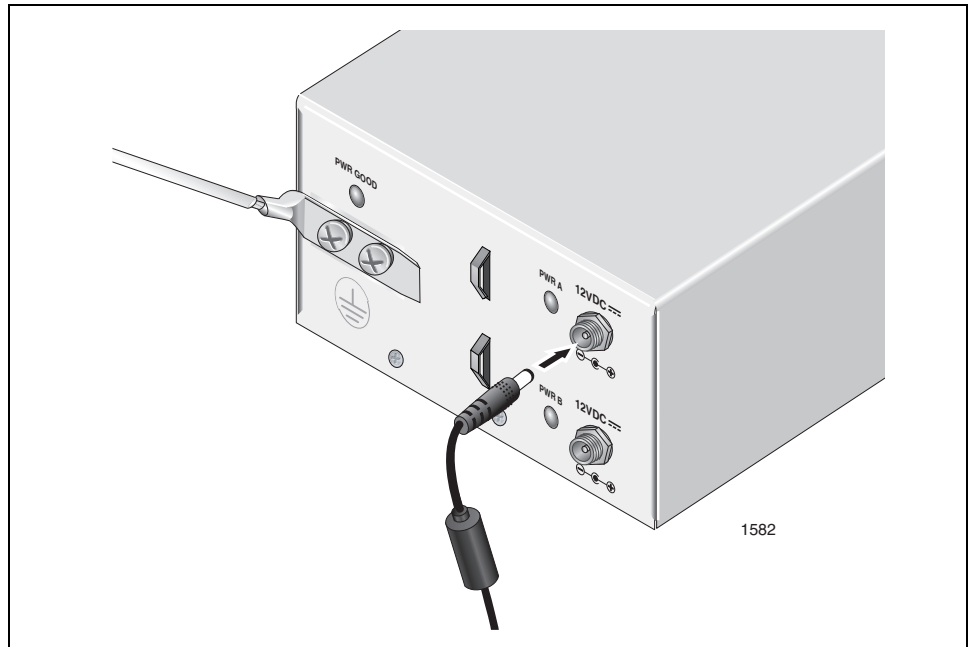

Figure 15. Connecting the Power Cord

3. To prevent accidentally disconnecting the power cord from the chassis, secure the cord to the tie anchor with a tie wrap.

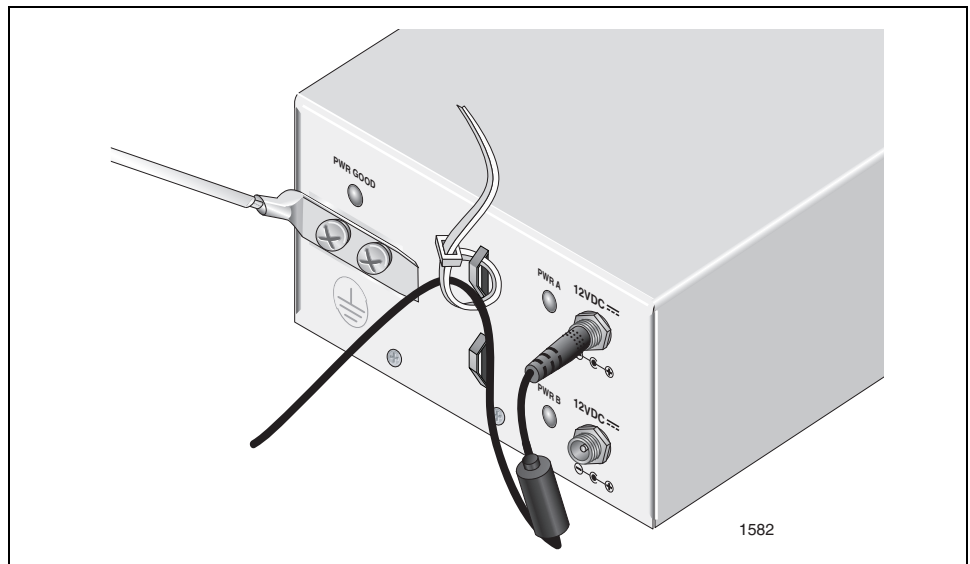

Figure 16. Securing the Power Cord with a Tie Wrap

4. Connect the power cord to an appropriate power source. For the power requirements, refer to “Power Specifications” on page 37. The chassis is now ready for network operations.



Warning: Power cord is used as a disconnection device. To de-energize equipment, disconnect the power cord. *↻* E3

Pluggable Equipment. The socket outlet shall be installed near the equipment and shall be easily accessible. *↻* E5

5. If you purchased a second power adapter, repeat this procedure to install it.

Note

Connecting the two power supplies to different circuits will protect the unit from a power circuit failure.

Verifying the Installation

After powering on the chassis, view the PWR GOOD LED. The LED should be ON. The PWR A and PWR B LEDs should also be ON for DC connectors that are connected to power adapters. If an LED is OFF, perform the following:

- ❑ Verify that the power cord is firmly connected to the AC power source and to the power adapter.
- ❑ Verify that the power adapter is firmly connected to a DC connector on the back panel of the chassis.
- ❑ Verify that the power source is operating properly by plugging a different device into it.
- ❑ Try connecting the power adapter to another power source, preferably located on a different circuit.
- ❑ Try using a different power adapter and power cord.
- ❑ Check that the voltage from the power source is within the required levels for your region.

For instructions on how to troubleshoot a problem with a line card, refer to the documentation that ships with the card.

Replacing a Line Card or the Management Card

All the Converteon media converter line cards and the AT-CV5M02 Management Card support hot-swapping and can be installed while the chassis is powered on.

To replace a line card, perform the following procedure:

1. Disconnect all the cables from the line card you want to remove from the chassis.
2. Insert the dust cap into the fiber optic port on the line card.
3. Using a Phillips-head screwdriver, loosen the captive screw of the line card.
4. Slide the line card from the chassis.
5. If you are replacing the line card, go to “Installing a Converteon Line Card” on page 27.
6. If you are not replacing the line card, insert the AT-CV5PNL1 slot cover in the slot and tighten the captive screw to secure it to the chassis.

Appendix A

Technical Specifications

Physical Specifications

Dimensions:	5.40 cm x 13.12 cm x 15.52 cm (2.12 in x 5.17 in x 6.11 in) (H x W x L):
Weight:	0.9 kg (1.98 lb)

Environmental Specifications

Operating Temperature:	0° C to 40° C (32° F to 104° F)
Storage Temperature:	-25° C to 70° C (-13°F to 158° F)
Operating Humidity:	5% to 90% non-condensing
Storage Humidity:	5% to 95% non-condensing
Maximum Operating Altitude:	3,000 m (10,000 ft.)
Maximum Storage Altitude:	4,000 m (13,100 ft.)

Power Specifications

Power Adapter Output	
Minimal Output:	9 VDC
Nominal Output:	12 VDC
Maximum Output:	15 VDC
Maximum Current:	3.3A @ 12 VDC
Output Connector:	Coaxial Female Barrel Inner Diameter: 2.5 mm Outer Diameter: 5.5 mm
Power Adapter Input	
Input Range:	100-240 AC @ 51-60 Hz
Input Connector:	IEC320-C14 (3-Pole AC inlet)

Safety and Electromagnetic Emissions Certifications

EMI:	FCC Class A, EN55022 Class A, VCCI Class A, C-TICK, CE
Immunity:	EN55024
Safety:	UL60950-1 (CUL _{US}), EN60950-1 (TUV), CAN/CSA C22.2 No. 60950-1
Laser:	EN60825
Quality and Reliability:	MTBF > 310,000 hrs. (Telcordia Standards)