

DRB Series

Industrial DC Power Supply

- AT-DRB15
- AT-DRB50



Installation Guide

Copyright © 2018 Allied Telesis, Inc.

All rights reserved. No part of this publication may be reproduced without prior written permission from Allied Telesis, Inc.

Allied Telesis and the Allied Telesis logo are trademarks of Allied Telesis, Incorporated. All other product names, company names, logos or other designations mentioned herein are trademarks or registered trademarks of their respective owners.

Allied Telesis, Inc. reserves the right to make changes in specifications and other information contained in this document without prior written notice. The information provided herein is subject to change without notice. In no event shall Allied Telesis, Inc. be liable for any incidental, special, indirect, or consequential damages whatsoever, including but not limited to lost profits, arising out of or related to this manual or the information contained herein, even if Allied Telesis, Inc. has been advised of, known, or should have known, the possibility of such damages.

General Safety Instructions:

READ SAFETY INSTRUCTIONS

Servicing:

These products are not customer serviceable TDK-Lambda UK LTD and their authorised agents only are permitted to carry out repairs.

Critical Components:

These products are not authorised for use as critical components in nuclear control systems, life support systems or equipment for use in hazardous environments without the express written approval of the Managing Director of TDK-Lambda EMEA.

Product Usage:

These products are designed for use within a host equipment which restricts access to authorised competent personnel.

This product is a component power supply considered apparatus and is only to be installed by qualified persons within other equipment and must not be operated as a stand-alone product.

This product is for sale to business to business customers and can be obtained via distribution channels. It is not intended for sale to end users.

This product is considered to be apparatus and complies with the EMC directive. Compliance with the EMC directive must be considered in the final installation. Please contact your local TDK-Lambda office

Environmental:

These products are IPX0, and therefore chemicals/solvents, cleaning agents and other liquids must not be used.

Environment:

This power supply is a switch mode power supply for use in applications within a Pollution Degree 2, overvoltage category II environment. Material Group IIIb PCB's are used within it.

Output Loading:

The output power taken from the power supply must not exceed the rating stated on the power supply label, except as stated in the product limitations in this handbook.

Input Parameters:

This product must be operated within the input parameters stated in the product limitations in this handbook.

End of Life Disposal:

The unit contains components that require special disposal. Make sure that the unit is properly disposed of at the end of its service life and in accordance with local regulations.

**RISK OF ELECTRIC SHOCK****High Voltage Warning:**

Dangerous voltages are present within the power supply. The professional installer must protect service personnel from inadvertent contact with these dangerous voltages in the end equipment.

WARNING: When installed in a Class 1 end equipment, this product must be reliably earthed and professionally installed.

The (+) or (-) output(s) can be earthed or left floating.

The unit cover(s)/chassis (where applicable) must not be made user accessible.

Internal fuses protect the unit and must not be replaced by the user. In case of internal defect, the unit must be returned to TDK-Lambda UK LTD or one of their authorised agents.

A suitable mechanical, electrical and fire enclosure must be provided by the end use equipment for mechanical, electric shock and fire hazard protection.

The ventilation openings on these products must not be impeded.

The unit cover/chassis, where applicable, is designed to protect skilled personnel from hazards. They must not be used as part of the external covers of any equipment where they may be accessible to operators, since under full load conditions, part or parts of the unit chassis may reach temperatures in excess of those considered safe for operator access.

Allgemeine Sicherheitsvorschriften:

LESEN SIE DIE SICHERHEITSVORSCHRIFTEN

Wartung:

Diese Produkte können nicht durch den Kunden gewartet werden. Nur TDK-Lambda UK LTD. und deren zugelassene Vertriebshändler sind zur Durchführung von Reparaturen berechtigt.

Kritische Komponenten:

Diese Produkte sind nicht für die Verwendung als kritische Komponenten in nuklearen Kontrollsystemen, Lebenserhaltungssystemen oder Geräten in gefährlichen Umgebungen geeignet, sofern dies nicht ausdrücklich und in Schriftform durch den Geschäftsführer von TDK-Lambda EMEA genehmigt wurde.

Produktverwendung:

Diese Produkte sind zur Verwendung innerhalb von Host-Anlagen gedacht, die einen auf das Fachpersonal beschränkten Zugang haben.

Dieses Produkt ist als eine Stromversorgungs-Baugruppe / Stromversorgungs-Einheit zu betrachten und es darf nur von qualifiziertem Personal in andere Geräte eingebaut werden und es darf NICHT als eigenständiges Gerät ("Stand-Alone") betrieben werden.

Dieses Produkt ist für den Verkauf an Geschäftskunden entwickelt worden und es kann über Distributionskanäle bezogen werden.

Es ist NICHT für den Verkauf an Endkunden gedacht und konzipiert.

Dieses Produkt ist als Gerät zu betrachten and entspricht der EMV Direktive. Die Konformität mit der EMV Direktive muss in der finalen Installation betrachtet werden. Bitte kontaktieren Sie Ihr regionales TDK-Lambda Vertriebsbüro bei Rückfragen

Umwelt:

Diese Produkte sind IPX0, aus diesem Grund dürfen keine Chemikalien/Lösungsmittel, Reinigungsmittel und andere Flüssigkeiten verwendet werden.

Umgebung:

Dieses Netzteil ist ein Schaltnetzteil zur Verwendung in einer Umgebung mit einem Verschmutzungsgrad 2, Überspannungskategorie II. Materialgruppe IIIb mit darin verwendeten PCBs.

Ausgangsstrom:

Der Ausgangsstrom des Netzteiles darf die Leistung, die auf dem Label des Netzteiles vermerkt ist, nur dann überschreiten, wenn dies in den Produktgrenzen dieses Handbuches ausgezeichnet ist.

Eingangsparameter:

Dieses Produkt muss innerhalb der Eingangsparameter, die in den Produktgrenzen dieses Handbuches angegeben sind, betrieben werden.

Entsorgung am Ende der Betriebszeit:

Das Gerät enthält Komponenten die unter Sondermüll fallen. Das Gerät muss am Ende der Betriebszeit ordnungsgemäß und in Übereinstimmung mit den regionalen Bestimmungen entsorgt werden.



GEFAHR DURCH ELEKTRISCHEN SCHLAG

Hochspannungswarnung:

Innerhalb des Netzteiles gibt es gefährliche Spannungen. Der Elektroinstallateur muss das Wartungspersonal vor versehentlichem Kontakt mit den gefährlichen Spannungen im Endgerät schützen.

WARNUNG! Falls Sie unser Netzgerät in eine Anwendung mit Schutzklasse 1 eingebaut haben, stellen Sie sicher, dass es fachgerecht installiert und zuverlässig geerdet ist.

Die (+) oder (-) Ausgänge können geerdet werden oder unangeschlossen bleiben.

Die Abdeckung des Gerätes/das Gehäuse darf für den Benutzer nicht zugänglich sein.

Eine interne Sicherung schützt das Gerät und darf durch den Benutzer nicht ausgetauscht werden. Im Fall von internen Defekten muss das Gerät an TDK-Lambda UK LTD oder einen der autorisierten Vertriebshändler zurückgeschickt werden.

Ein geeignetes mechanisches, elektrisches und brandgeschütztes Gehäuse muss als Schutz vor der Gefahr von mechanischen Risiken, Stromschlägen und Brandschutz in dem Endgerät vorgesehen werden.

Die Belüftungsöffnungen an diesem Produkt dürfen nicht blockiert werden.

Die Geräteabdeckung/das Gehäuse ist so entworfen, dass das Fachpersonal vor Gefahren geschützt wird. Sie dürfen nicht als Teil der externen Abdeckung für Geräte verwendet werden, die für den Betreiber zugänglich sein müssen, da Teile oder das gesamte Gerätegehäuse unter voller Auslastung übermäßige Temperaturen erreichen kann, die für den Zugang des Betreibers nicht mehr als sicher betrachtet werden.

Consignes générales de sécurité:

LIRE LES CONSIGNES DE SECURITE

Entretien:

Ces produits ne peuvent pas être réparés par l'utilisateur. Seuls, TDK-Lambda UK LTD et ses agents agréés sont autorisés à effectuer des réparations.

Composants critiques:

Ces produits ne doivent pas être utilisés en tant que composants critiques dans des systèmes de commande nucléaire, dans des systèmes de sauvetage ou dans des équipements utilisés dans des environnements dangereux, sans l'autorisation écrite expresse du directeur général de TDK-Lambda EMEA.

Utilisation du produit:

Ces produits sont conçus pour être utilisés dans un équipement hôte dont l'accès n'est autorisé qu'aux personnes compétentes.

Ce produit est une alimentation considérée comme un appareil devant être installé par des personnes qualifiées, dans un autre équipement. Il ne doit pas être utilisé en tant que produit fini.

Ce produit est destiné à la vente entre entreprises et peut être obtenu via des canaux de distribution.

Il n'est pas prévu à la vente pour les particuliers.

Ce produit considéré comme un appareil conforme à la directive CEM. Le respect de la directive CEM doit être pris en compte dans l'installation finale. Veuillez contacter votre bureau TDK-Lambda le plus proche.

Environnement:

Ces produits sont IPX0, et donc on ne doit pas utiliser des produits chimiques/solvants, des produits de nettoyage et d'autres liquides.

Environnement fonctionnel :

Cette alimentation fonctionne en mode commutation pour utilisation dans des applications fonctionnant dans un environnement avec Degré de Pollution 2 et catégorie de surtension II. Elle utilise des cartes des circuits imprimés (PCB) de Groupe IIIb.

Intensité soutirée:

L'intensité soutirée de l'alimentation ne doit pas dépasser l'intensité nominale marquée sur la plaque signalétique, sauf indications contraires dans les limitations du produit décrit dans ce manuel.

Paramètres d'entrée:

Ce produit doit être utilisé à l'intérieur des paramètres d'entrée indiqués dans les limitations du produit dans ce manuel.

Élimination en fin de vie:

L'alimentation contient des composants nécessitant des dispositions spéciales pour leur élimination. Vérifiez que cette alimentation est mise au rebut correctement en fin de vie utile et conformément aux réglementations locales en vigueur.

**RISQUE DE CHOC ELECTRIQUE****Attention-Danger haute tension :**

Des tensions dangereuses sont présentes dans l'alimentation. L'installateur doit protéger le personnel d'entretien contre un contact involontaire avec ces tensions dangereuses dans l'équipement final.

AVERTISSEMENT: Si ce produit est installé dans un équipement final de classe I, il doit être mis à la terre de manière fiable et installé par un professionnel averti.

Les sorties (+) ou (-) peuvent être raccordées à la terre ou laissées flottantes.

Le couvercle/châssis de l'alimentation ne doit pas être accessible à l'utilisateur.

Un fusible interne protège le module et ne doit pas être remplacé par l'utilisateur. En cas de défaut interne, le module doit être renvoyé à TDK-Lambda UK LTD ou l'un de ses agents agréés.

Une enceinte appropriée doit être prévue par l'utilisateur final pour assurer la protection contre les chocs mécaniques, les chocs électriques et l'incendie.

Les orifices de ventilation sur ces produits ne doivent pas être obstrués.

Le couvercle et le châssis du module sont conçus pour protéger des personnels expérimentés. Ils ne doivent pas être utilisés comme couvercles extérieurs d'un équipement, accessible aux opérateurs car en condition de puissance maximum, des parties du châssis peuvent atteindre des températures considérées comme dangereuses pour l'opérateur.

Norme generali di sicurezza:

SI PREGA DI LEGGERE LE NORME DI SICUREZZA

Manutenzione:

Il cliente non può eseguire alcuna manutenzione su questi prodotti. L'esecuzione delle eventuali riparazioni è consentita solo a TDK-Lambda UK LTD e ai suoi agenti autorizzati.

Componenti critici:

Non si autorizza l'uso di questi prodotti come componenti critici all'interno di sistemi di controllo nucleari, sistemi necessari alla sopravvivenza o apparecchiature destinate all'impiego in ambienti pericolosi, senza l'esplicita approvazione scritta dell'Amministratore Delegato di TDK-Lambda EMEA.

Uso dei prodotti:

Questi prodotti sono progettati per l'uso all'interno di un'apparecchiatura ospite che limiti l'accesso al solo personale competente e autorizzato.

Questo prodotto è un alimentatore professionale componente considerato apparato e come tale deve essere installato da qualificato personale all'interno di altre apparecchiature e non deve essere utilizzato come prodotto indipendente.

Questo prodotto è vendibile solo ad utilizzatori e compratori professionali, attraverso i vari canali di distribuzione. Questo prodotto non è inteso per la vendita al dettaglio o agli utilizzatori finali.

Questo prodotto è da considerarsi come apparato e conforme con la direttiva EMC. Conformità alla direttiva EMC deve essere considerata nell'installazione finale. Gli uffici di TDK-Lambda Sas Succursale Italiana sono a vostra disposizione per ulteriori ragguagli.

Condizioni ambientali:

Questi prodotti sono classificati come IPX0, dunque non devono essere utilizzati sostanze chimiche/solventi, prodotti per la pulizia o liquidi di altra natura.

Ambiente:

Questo prodotto è un alimentatore a commutazione, destinato all'uso in applicazioni rientranti in ambienti con le seguenti caratteristiche: Livello inquinamento 2, Categoria sovratensione II. Questo prodotto contiene schede di circuiti stampati in materiali di Gruppo IIIb.

Carico in uscita:

La potenza in uscita ottenuta dall'alimentatore non deve superare la potenza nominale indicata sulla targhetta dell'alimentatore, fatto salvo dove indicato nei limiti per il prodotto specificati in questo manuale.

Parametri di alimentazione:

Questo prodotto deve essere utilizzato entro i parametri di alimentazione indicati nei limiti per il prodotto, specificati in questo manuale.

Smaltimento:

L'unità contiene componenti che richiedono procedure speciali di smaltimento. Accertarsi che l'unità venga smaltita in modo corretto al termine della vita utile e nel rispetto delle normative locali.

**RISCHIO DI SCOSSA ELETTRICA****Avvertimento di alta tensione:**

All'interno dell'alimentatore sono presenti tensioni pericolose. Gli installatori professionali devono proteggere il personale di manutenzione dal rischio di contatto accidentale con queste tensioni pericolose all'interno dell'apparecchiatura finale.

ATTENZIONE: Se installato in un'attrezzatura di classe I, questo prodotto deve essere collegato a terra in modo affidabile ed installato in modo professionale.

Le uscite (+) o (-) possono essere messa a terra o lasciate isolate.

I coperchi/il telaio dell'unità non devono essere accessibili da parte dell'utente.

Un fusibile interno protegge l'unità e non deve essere sostituito dall'utente. Nell'eventualità di un difetto interno, restituire l'unità a TDK-Lambda UK LTD o a uno dei suoi agenti autorizzati.

L'apparecchiatura finale deve includere una recinzione meccanica, elettrica e antincendio per proteggere dai pericoli di natura meccanica, dalle scosse elettriche e dai pericoli di incendio.

Le griglie di ventilazione su questi prodotti non devono essere ostruite.

Il coperchio/telaio dell'unità è realizzato per proteggere il personale esperto dai pericoli. Non deve essere usato come parte degli involucri esterni di qualsiasi apparecchiatura, se risulta accessibile da parte degli addetti, poiché è possibile che in condizioni di pieno carico una o più parti del telaio dell'unità giunga/giungano a temperature superiori ai limiti considerati sicuri per l'accesso da parte degli addetti.

Instrucciones generales de seguridad:

LEA LAS INSTRUCCIONES DE SEGURIDAD

Servicio:

Estos productos no pueden ser reparados por los clientes. TDK-Lambda UK LTD. y sus agentes autorizados son los únicos que pueden llevar a cabo las reparaciones.

Componentes fundamentales:

Estos productos no pueden ser utilizados como componentes fundamentales en sistemas de control nuclear, sistemas de soporte vital o equipos a utilizar en entornos peligrosos sin el consentimiento expreso por escrito del Director General de TDK-Lambda EMEA.

Uso de los productos:

Estos productos han sido diseñados para ser utilizados en un equipo central que restrinja el acceso al personal cualificado autorizado.

Este producto es un aparato considerado fuente de alimentación y sólo para ser instalado por personas cualificadas dentro de otros equipos y no debe ser operado como un producto independiente .

Este producto está a la venta entre profesionales y se puede obtener a través de los canales de distribución . No está destinado para la venta a los usuarios finales .

Este producto es considerado un producto electrónico y cumple con la directiva EMC. Dicho cumplimiento debe ser considerado sobre la instalación final. Por favor, contacte con su oficina o distribuidor local de TDK-Lambda

Medioambiental:

Estos productos son IPX0 y, por tanto, no pueden utilizarse sustancias químicas/disolventes, agentes de limpieza ni otros líquidos.

Medio ambiente:

Esta fuente de alimentación es una fuente de alimentación de modo conmutado a utilizar en aplicaciones dentro de un entorno con un Grado de contaminación 2 y una Categoría de sobretensión II. En él se utilizan policloruros de bifenilo del Grupo de materiales IIIb.

Carga de salida:

La potencia de salida tomada de la fuente de alimentación no puede sobrepasar el valor nominal indicado en la etiqueta de la fuente de alimentación, excepto en los casos indicados en las limitaciones del producto en este manual.

Parámetros de entrada:

Este producto debe ser utilizado dentro de los parámetros de entrada indicados en las limitaciones del producto en este manual.

Desecho de la unidad:

La unidad contiene componentes que deben ser desechados de una manera especial. Asegúrese de desechar correctamente la unidad al final de su vida útil y conforme a las normas locales vigentes.

**PELIGRO DE DESCARGAS ELÉCTRICAS****Advertencia de alta tensión:**

En esta fuente de alimentación hay tensiones peligrosas. El instalador profesional debe proteger al personal de servicio contra cualquier contacto accidental con estas tensiones peligrosas en el equipo final.

ADVERTENCIA: La instalación de este producto en un equipo de clase I la deben llevar a cabo profesionales y el producto debe estar conectado a tierra.

La salida o salidas (+) o (-) pueden conectarse a tierra o se las puede dejar flotando.

Debe impedirse el acceso de los usuarios a la cubierta o cubiertas y al chasis de la unidad.

Un fusible interno protege la unidad y este no debe ser nunca reemplazado por el usuario. En caso de existir algún defecto interno, la unidad debe ser enviada a TDK-Lambda UK LTD o a uno de sus agentes autorizados.

El equipo de uso final debe constituir un recinto de protección mecánica, eléctrica y contra incendios de protección mecánica, contra descargas eléctricas y contra el peligro de incendios.

Las aberturas de ventilación de estos productos no deben obstruirse jamás.

La cubierta/chasis de la unidad ha sido diseñada para que proteja a las personas cualificadas de los peligros. No deben ser utilizadas como parte de las cubiertas externas de cualquier equipo al que pueden acceder los operarios, ya que bajo unas condiciones de carga completa, la pieza o piezas del chasis de la unidad pueden alcanzar temperaturas superiores a las consideradas seguras para el acceso de los operarios.

Instruções gerais de segurança:

LEIA AS INSTRUÇÕES DE SEGURANÇA

Manutenção:

Estes produtos não são podem ser submetidos a manutenção por parte do cliente. Apenas a TDK-Lambda UK LTD e os seus agentes autorizados têm permissão para realizar reparações.

Componentes essenciais:

Não é autorizada a utilização destes produtos como componentes essenciais de sistemas de controlo nuclear, sistemas de suporte de vida ou equipamento para utilização em ambientes perigosos sem a expressa autorização por escrito do Director-Geral da TDK-Lambda EMEA.

Utilização do produto:

Estes produtos foram concebidos para utilização dentro de um equipamento de alojamento que apenas permita o acesso a pessoal qualificado autorizado.

Este produto é uma alimentação considerado com um aparelho para ser instalado por pessoas qualificadas em outros equipamentos.

Não deve ser usado como um produto acabado.

Este produto é destinado para venda entre as empresas e pode ser obtido através de canais de distribuição.

Não se destina à venda aos particulares.

Este produto considerado com um aparelho de acordo com a directiva CEM.

Conformidade com a directiva CEM devem ser considerados na instalação final.

Entre em contacto com seu escritório TDK-Lambda mais próximo

Ambiental:

Estes produtos são IPX0 e, como tal, não se devem utilizar químicos/solventes, agentes de limpeza e outros líquidos.

Ambiente:

Esta fonte de alimentação é uma fonte de alimentação do modo de comutação para utilização em aplicações com um Nível de Poluição 2 e ambientes da categoria de sobretensão II. São utilizadas placas de circuitos impressos do grupo de materiais IIIb.

Carga de saída:

A potência de saída extraída da fonte de alimentação não deve exceder a classificação assinalada na etiqueta da fonte de alimentação, excepto quando indicado nas limitações do produto neste guia.

Parâmetros de entrada:

Este produto deve ser utilizado dentro dos parâmetros de entrada indicados nas limitações do produto neste guia.

Eliminação no fim de vida:

A unidade contém componentes que necessitam de procedimentos especiais de eliminação. Certifique-se de que a unidade é devidamente eliminada no fim da sua vida útil e que tal é feito em conformidade com os regulamentos locais.

**RISCO DE CHOQUE ELÉCTRICO****Aviso de alta tensão:**

Estão presentes tensões perigosas dentro da fonte de alimentação. O profissional que realizar a instalação deve proteger o pessoal de assistência contra contactos inadvertidos com estas tensões perigosas do equipamento final.

AVISO: Quando instalado num equipamento de Classe I, este produto deve ser ligado à terra de forma fiável e instalado por um profissional.

As saídas (+) e (-) podem ser ligadas à terra ou deixadas soltas.

O chassis/cobertura(s) da unidade não deve estar acessível ao utilizador.

Existe um fusível interno que protege a unidade e que não deve ser substituído pelo utilizador. Em caso de defeito interno, a unidade deve ser devolvida à TDK-Lambda UK LTD ou a um dos seus agentes autorizados.

O equipamento de utilização final deve fornecer um bastidor com protecção mecânica, eléctrica e contra incêndios adequada.

As aberturas de ventilação destes produtos não devem ser obstruídas.

O chassis/cobertura da unidade está concebido de forma a proteger o pessoal especializado de perigos. Não devem ser utilizados como parte das coberturas externas de qualquer equipamento em que possam estar acessíveis aos operadores, uma vez que em condições de carga máxima, algumas peças do chassis da unidade podem atingir temperaturas superiores às consideradas seguras para o acesso do operador.



DRB-1 Series

Instruction Manual

BEFORE USING THE POWER SUPPLY UNIT

Pay attention to all warnings and cautions before using the unit. Incorrect usage could lead to an electrical shock, damage to the unit or a fire hazard.

- **Warning Symbols**

CAUTION	
. DO NOT MODIFY, DISASSEMBLE THE POWER SUPPLY.	
. READ INSTRUCTION MANUAL BEFORE CONNECTING TO MAINS.	
. ELECTRIC SHOCK HAZARDOUS ON THE CONNECTOR SECTION.	

NOTICE:

Installing/Storage Environment

1. Store the product with ambient temperature -40 to +85 °C, and relative humidity 5 to 95% (No Dewdrop).
2. Avoid operating the unit in over current, short circuit conditions or outside the specified input voltage range as damage may occur.
3. Confirm connections to input/output terminals are correct as indicated in the instruction manual.
4. Use the product where the relative humidity is 5 to 95% (No Dewdrop).
5. Avoid places where the product is subjected to direct sun light.
6. Avoid places where the products is subjected to penetration of liquid, foreign substance or corrosive gas.

DWG NO. : CA798-04-01		
APPD	CHK	DWG
	zhouXin	Jenny
20/Dec/13	20/Dec/13	20/Dec/13

7. Avoid places subject to shock or vibration.

A device such as a contact breaker may be a vibration source. Set the Power Supply as far as possible from possible sources of shock or vibration.

8. If the Power Supply is used in an area with excessive electronic noise, be sure to separate the Power Supply as far as possible from the noise sources.

9. Don't use the product in the environment with strong electromagnetic field, corrosive gas and conductive substance.

Precautions in Using the product:

When the product is used under the circumstance or environment below, ensure adherence to limitations of the ratings and functions.

Also take countermeasures for safety precautions such as fail-safe installations.

1. Under the circumstances or environment which are not described in the instruction manual.
2. For nuclear power control, railway, aircraft, vehicle, incinerator, medical equipment, entertainment equipment, safety device etc...
3. For applications where death or serious property damage is possible and extensive safety precautions are required.
4. Don't recommend using input power source with large inductance, which may cause power supply operate unstably.

Note: CE MARKING

CE Marking, when applied to a product covered by this handbook indicates compliance with:
Restriction Of the use of certain Hazardous Substances Directive 2011/65/EU (RoHS2)
Low Voltage Directive 2006/95/EC
EMC Directive 2004/108/EC the low voltage Directive 2006/95/EC

1. Model name identification method

DRB 15 -24 - 1

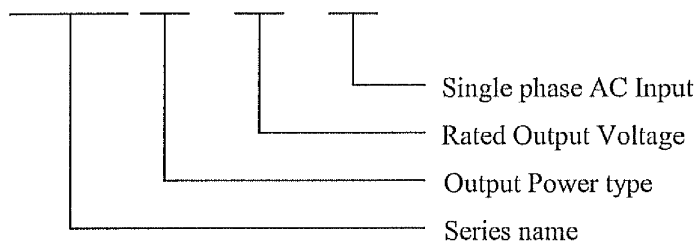

2. Terminal Explanation

2-1. DRB15-1

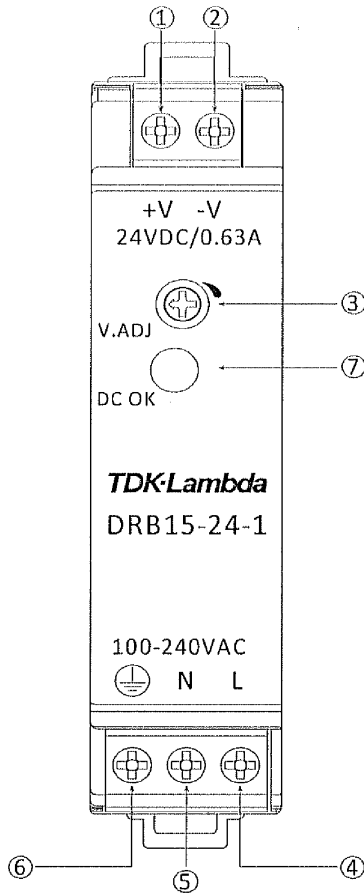

2-2. DRB30-1

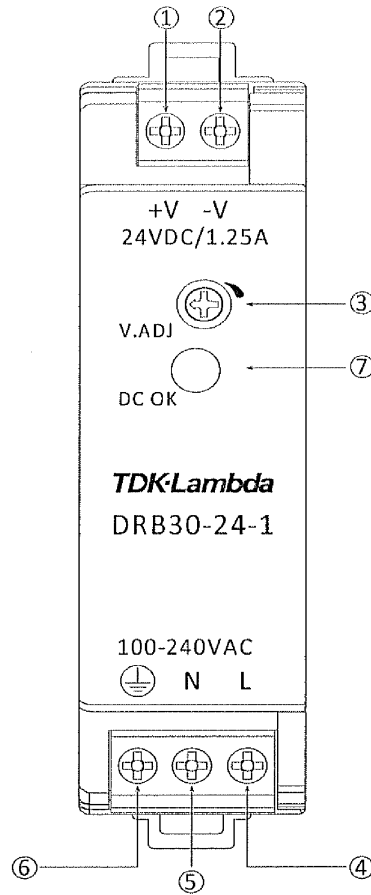

- ① +V: +Output terminal
- ② - V: - Output terminal
- ③ V.ADJ: Output voltage adjust trimmer
The output voltage rises when a trimmer is turned clockwise.
- ④ L: AC Input terminal
Live line (fuse in line)
- ⑤ N: AC Input terminal
Neutral line
- ⑥ : Protective Earth
Connect to safety ground of apparatus or equipment.
- ⑦ DC OK : Green LED lights when Output Voltage on

- ① +V: +Output terminal
- ② - V: - Output terminal
- ③ V.ADJ: Output voltage adjust trimmer
The output voltage rises when a trimmer is turned clockwise.
- ④ L: AC Input terminal
Live line (fuse in line)
- ⑤ N: AC Input terminal
Neutral line
- ⑥ : Protective Earth
Connect to safety ground of apparatus or equipment.
- ⑦ DC OK : Green LED lights when Output Voltage on

2-3 DRB50-1

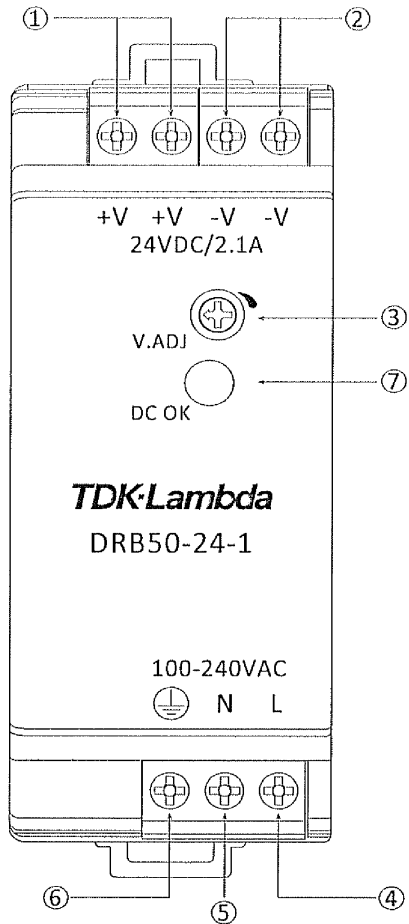

- ① +V: +Output terminal
- ② - V: - Output terminal
- ③ V.ADJ: Output voltage adjust trimmer
The output voltage rises when a trimmer is turned clockwise.
- ④ L: AC Input terminal
Live line (fuse in line)
- ⑤ N: AC Input terminal
Neutral line
- ⑥ : Protective Earth
Connect to safety ground of apparatus or equipment.
- ⑦ DC OK : Green LED lights when Output Voltage on

2-4 DRB100-1

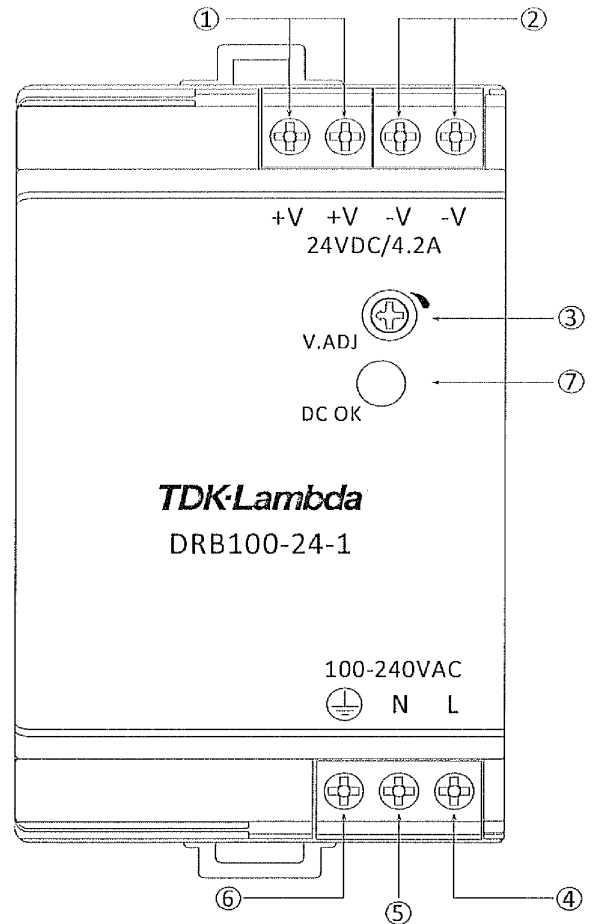

- ① +V: +Output terminal
- ② - V: - Output terminal
- ③ V.ADJ: Output voltage adjust trimmer
The output voltage rises when a trimmer is turned clockwise.
- ④ L: AC Input terminal
Live line (fuse in line)
- ⑤ N: AC Input terminal
Neutral line
- ⑥ : Protective Earth
Connect to safety ground of apparatus or equipment.
- ⑦ DC OK : Green LED lights when Output Voltage on

3. Terminal Connecting Method

Pay attention to the input wiring. If it is connected to wrong terminal, the power supply will be damaged.

- Input must be off when making connections.
- Connect ⊕ (Protective Earth) terminal of input connector to ground terminal of the equipment.
- The output load line and input line shall be separated and twisted to improve noise sensitivity.

When connecting or removing input and output wire, do not apply stress to PCB.

3-1 DRB15-1

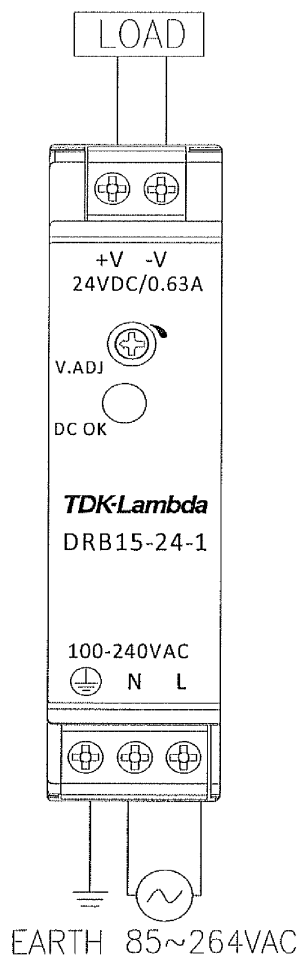

3-2 DRB30-1

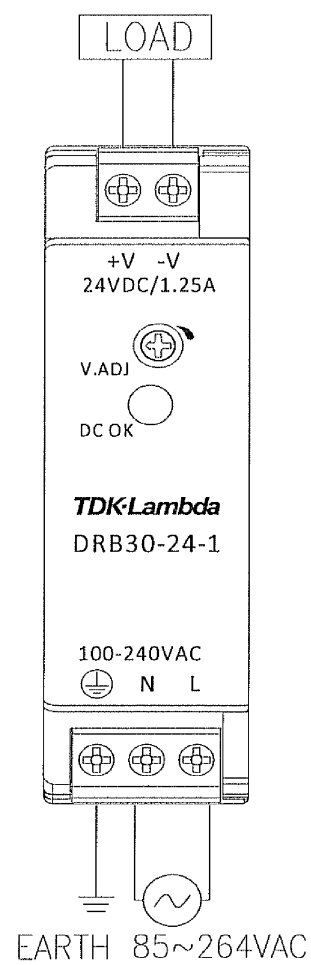

3-3 DRB50-1

3-4 DRB100-1

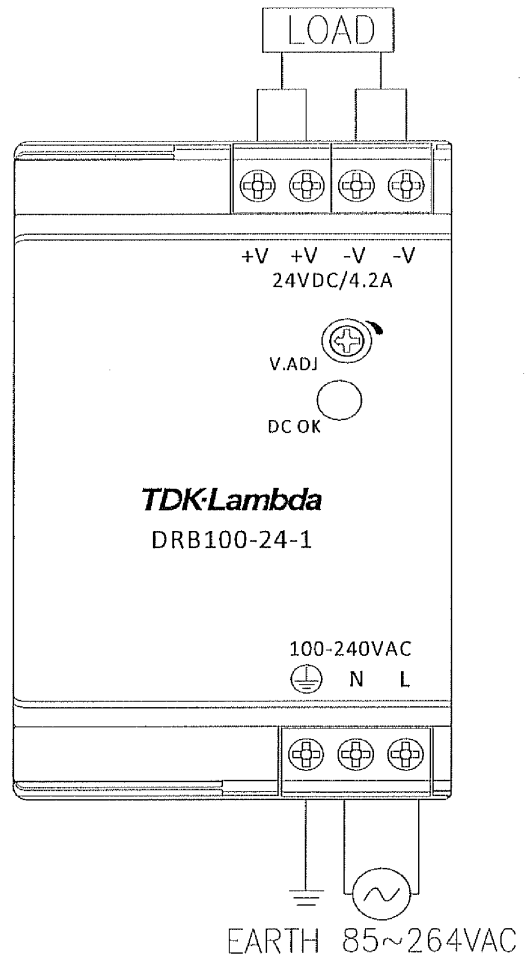
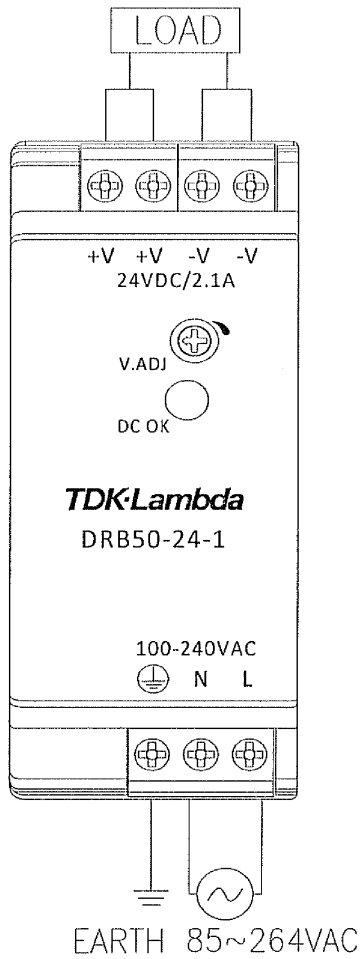

4. Explanation of Functions and Precautions

4-1. Input Voltage Range

Input voltage range is single phase 85 ~ 264VAC (47~63Hz) (not safety approved condition). For cases where conformance to various safety specs (UL, CSA, EN) are required, input voltage range will be 100 ~ 240VAC (50/60Hz). Power supply can withstand 300VAC surge for 5 seconds during operation. Input voltage which is out of specification may cause unit damage.

4-2. Output Voltage Range

Output voltage is set to the rated value at shipment. V.ADJ trimmer on the front panel side can be used to adjust the output voltage within the range specified (refer to specifications for adjustable range).

To turn the trimmer clockwise, the output voltage will be increased. Take note when the output voltage is increased excessively, over voltage protection (OVP) function may trigger and output voltage will be shut down.. Furthermore, when increasing the output voltage, reduce the output current so as not to exceed the maximum output power.

4-3. Inrush Current

This series has used Power Thermistor to protect the circuit from Inrush Current. Please carefully select input switch and fuse in cases of the high temperature and re-input the power.

4-4. Over Voltage Protection (OVP)

The OVP function (Inverter shutdown method, manual reset type) is provided. OVP function operates within specified range (refer to specification) of the rated output voltage value and the output will be shut down when OVP function triggers (refer to specifications for OVP range of each models). To reset OVP, remove the input of power supply for a few minutes, and then re-input. OVP value is fixed and not to be adjusted externally. Never apply more than rated output voltage to output terminal, which may leads to damage. In the case of inductive load, put protective diode in series to the output power line.

4-5. Over Current Protection (OCP)

Hiccup mode with automatic recovery.
OCP function operates when the output current exceeds OCP specification. The output will be automatically recovered when the overload condition is cancelled. Do not operate overload or dead short conditions for more than 30 seconds, which could result in damage or insulation failure. Due to internal protective function , output short causes DRB15-1, DRB30-1 hiccup or latch up, and causes DRB50-1, DRB100-1 hiccup.

4-6. Output Ripple & Noise

The standard specification for maximum ripple value is measured according to measurement circuit as below. When load lines are longer, ripple becomes larger. In this case, electrolytic capacitor, film capacitor, etc. might be necessary to use across the load terminal. The output ripple cannot be measured accurately if the probe ground lead of oscilloscope is too long.

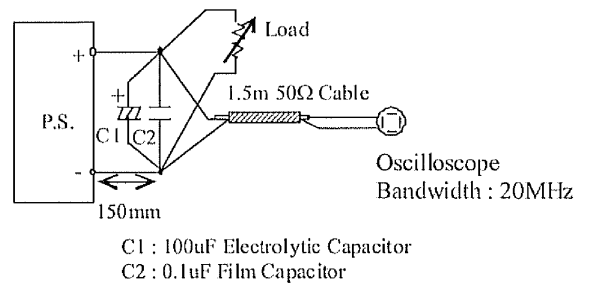

4-7. Series Operation

For series operation, either method (A) or (B) is possible.

Method (A)

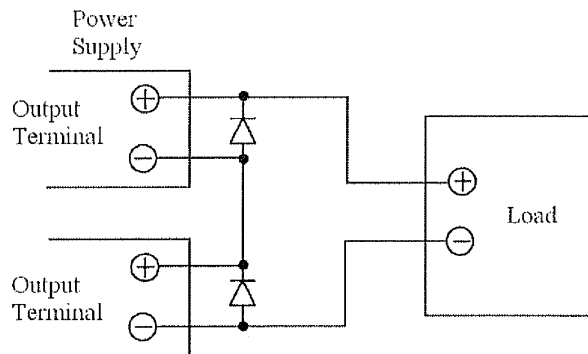

Method (B)

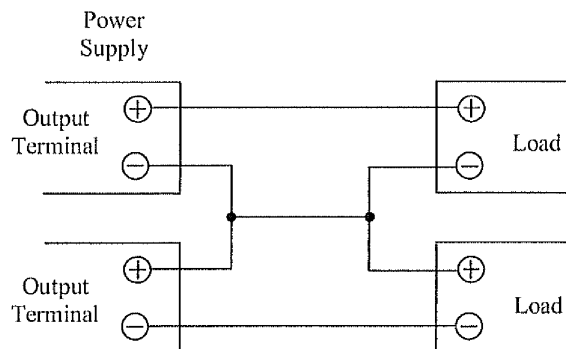

4-8. Parallel Operation

(A) To increase the output current is not possible.

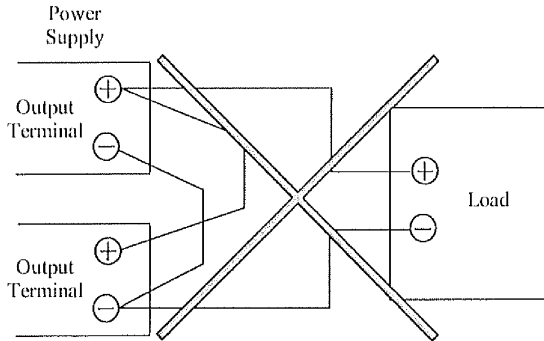

(B) To use as Back-up Power Supply

1. Set power supply output voltage higher by the forward voltage drop(VF) of diode
2. Adjust the output voltage of each power supply to be the same.
3. Use within the specifications for output voltage and output power.

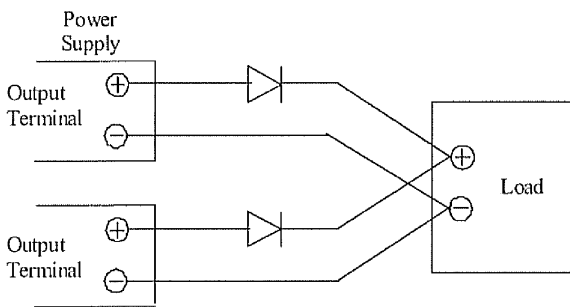

4-9. Isolation Test

Isolation resistance between output and \oplus (Protective Earth) shall be more than 100M Ω at 500VDC. For safety operation, voltage setting of DC isolation tester must be done before the test. Ensure that the unit is fully discharged after the test.

Output ~ \oplus (Protective Earth) : 500VDC 100M Ω or more

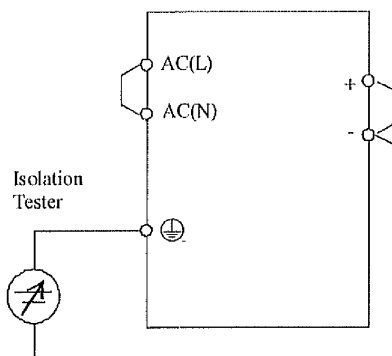

4-10. Withstand Voltage

This series is designed to withstand 3.0kVAC between input and output, 1.5kVAC between input and \oplus (Protective Earth) and 500VAC between output and the \oplus (Protective Earth) each for 1 minute. When testing withstand voltage, set current limit of the withstand voltage test equipment to 20mA (Output - \oplus (Protective Earth) : 100mA). The applied voltage must be gradually increased from zero to the testing value and then gradually decreased for shut down. When timer is used, the power supply may be damaged by high impulse voltage at timer switch on and off. Connect input and output as follows.

Input ~ Output (dotted line)

3kVAC 1min. (20mA)

Input ~ \oplus (Protective Earth) (solid line)

1.5kVAC 1min. (20mA)

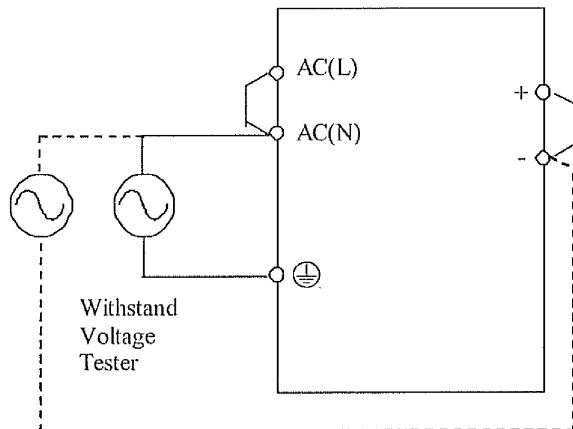

Output ~ \oplus (Protective Earth)

500VAC 1min. (100mA)

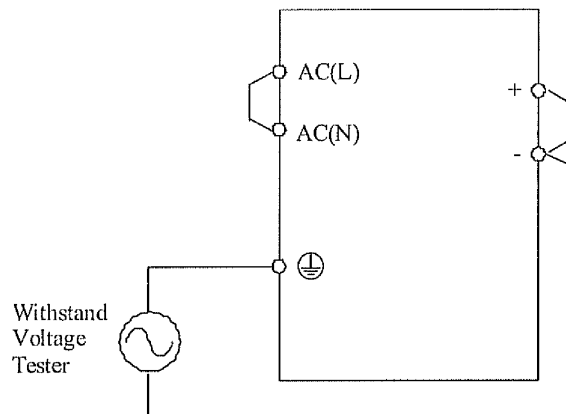

5. Mounting Directions

5-1. Mounting Directions

Recommended standard mounting method is (A). Please do not use installation method (B). Refer to the derating below. Do not exceed the load deratings. Leave enough space surround the units to ventilate heat efficiently.

Normal mounting (A)

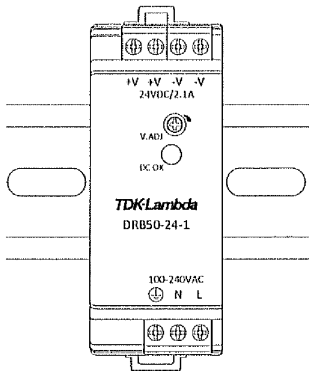

Back Down Mounting (B)

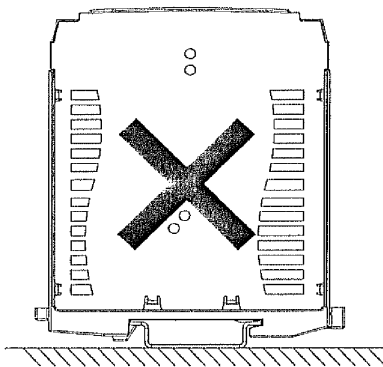

5-2. Output Derating

(Ts: measured at 50mm beneath the unit or less)

DRB15-1

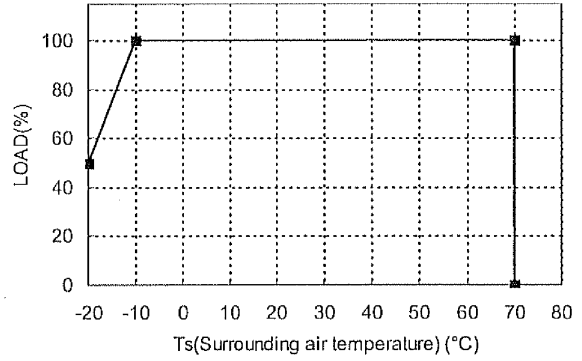

DRB30-1

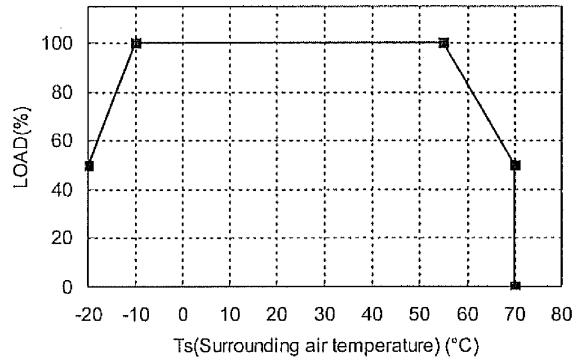

DRB50-1

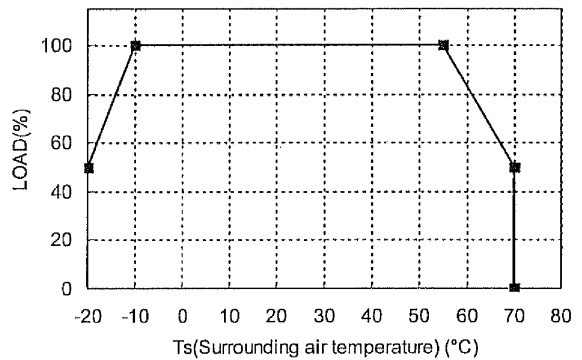

DRB100-1

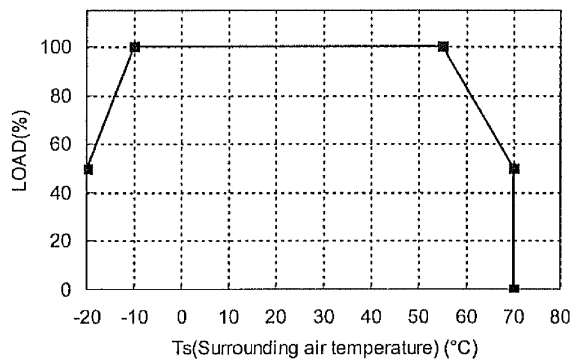

5-3. Surrounding space

Refer to below table to provide sufficient distance (X) when unit mounted with other devices at limited top/bottom space (Y,Z).

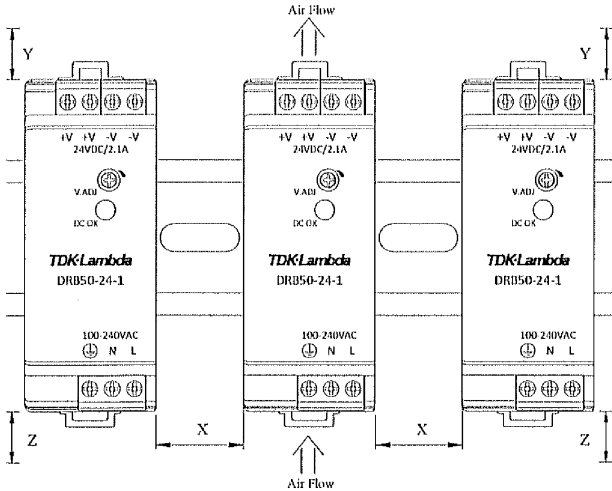

Y= 40mm minimum ; Z=20mm minimum.

(1) In the case that adjacent device is a cold source, X minimum refer to the table below:

Model	100%Load
DRB15-1	0mm
DRB30-12-1	20mm
DRB30-24-1	10mm
DRB50-1	15mm
DRB100-1	25mm

(2) In the case that adjacent device is a heat source (like the other power unit). X minimum refer to the table below:

Model	Ts	50%Load	100%Load
DRB15-1	55°C	0mm	0mm
	70°C	0mm	10mm

Model	Ts	95%Load	100%Load
DRB30-12-1	—	20mm	70mm
DRB30-24-1	—	10mm	40mm

Model	Ts	50%Load	100%Load
DRB50-5-1	—	15mm	25mm
DRB50-12-1	—	15mm	25mm
DRB50-24-1	—	15mm	15mm
DRB50-48-1	—	15mm	15mm

Model	Ts	95%Load	100%Load
DRB100-1	—	25mm	80mm

6. Wiring Method

- The output load line and input line shall be separated and twisted to improve noise sensitivity.
- Use all lines as thick and short as possible to make lower impedance.
- Noise can be eliminated by attaching a capacitor to the load terminals.
- EMI reduction performance by winding the cable around the toroidal ferrite core several times. Use any appropriate commercially available ferrite core from local vendor.
- For safety and EMI considerations, connect ⊕ (Protective Earth) terminal of input connector to ground terminal of equipment.
- Recommended screw torque is 0.51N.m (4.5Lb.inch).
- Recommended wire type: solid and stranded, AWG 12~24(wire strip length:4~5mm , 5mm max).

7. Internal and External Fuse Rating

(1) Internal fuse information:

DRB15-1	021502.5MXEP (Littelfuse) (AC250V T2.5AH)
DRB30-1	021502.5MXEP (Littelfuse) (AC250V T2.5AH)
DRB50-1	02153.15MXEP (Littelfuse) (AC250V T3.15AH)
DRB100-1	02153.15MXEP (Littelfuse) (AC250V T3.15AH)

(2) External fuse rating:

Refer to the following fuse rating when selecting the external fuses that are to be used on input line. Surge current flows when line turns on. Use slow-blow fuse or time-lag type fuse. Do not use fast-blow fuse. Fuse rating is specified by in-rush current value at line turn-on. Do not select the fuse according to input current (RMS.) values under the actual load condition.

DRB15-1	AC250V 2.5A~8A
DRB30-1	AC250V 2.5A~8A
DRB50-1	AC250V 3.15A~8A
DRB100-1	AC250V 3.15A~8A

8-1. Power supply mounting on DIN RAIL (TS35 or equivalent)

Make sure input and output wire disconnected when mount power supply onto rail

- (1) Tilt the unit slightly rearwards, fit the unit over top hat rail.

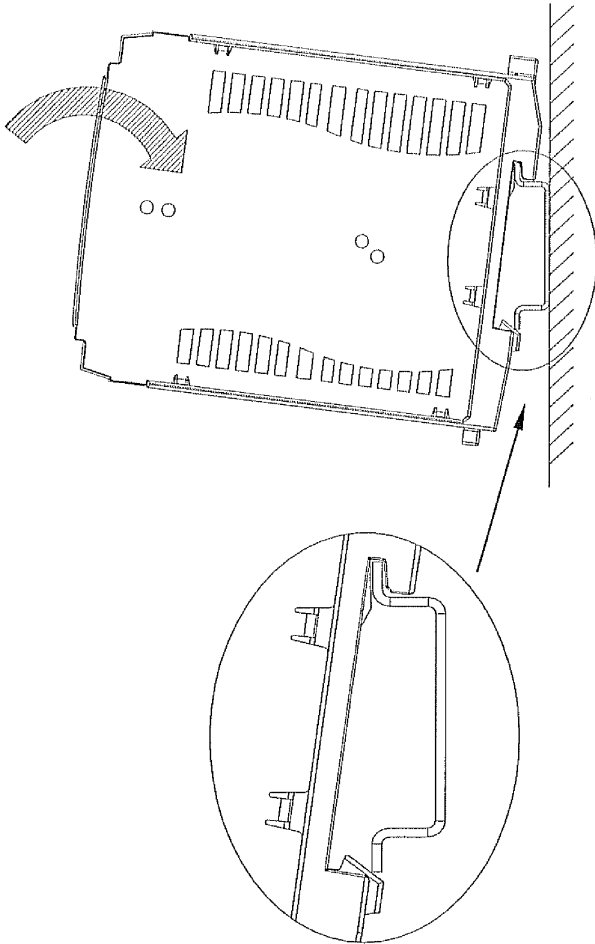

- (3) Press against the bottom front side for locking. Shake the unit slightly to check the locking action.

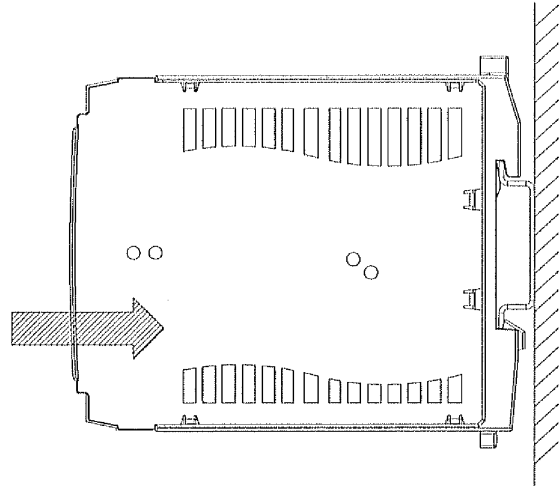

8-2. Power supply removal from DIN RAIL

Switch main power off and disconnect your system from the supply network. Push the button on the rear upper edge of the unit or move the removal hole on the rear down edge downwards by rotating screw driver. Gently lift lower front edge of the unit (tipping) and remove it.

- (2) Slide it downward until it hits the stop.

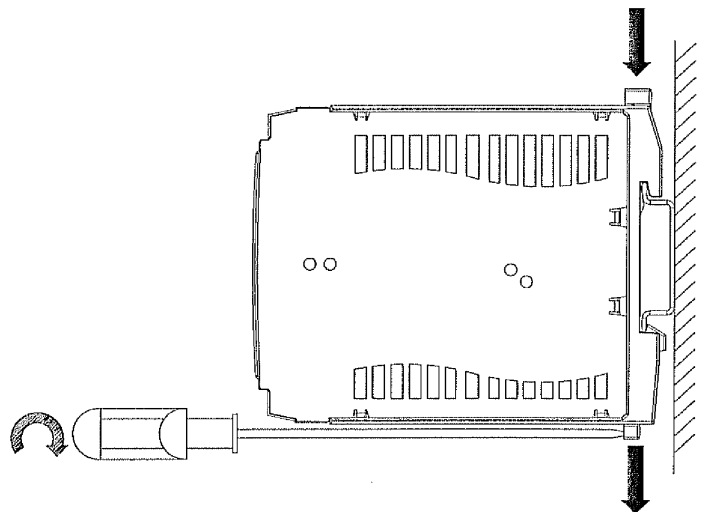
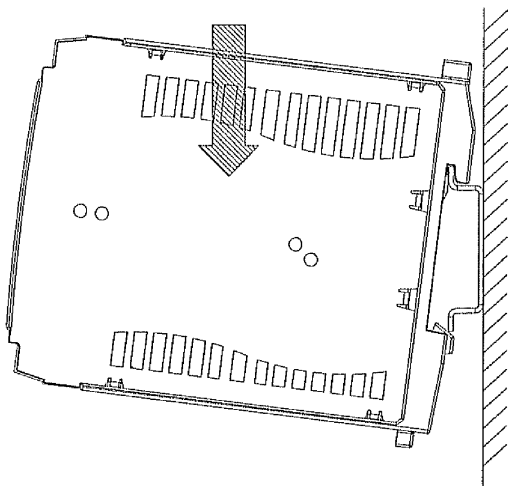

9. Before concluding that the unit is at fault...

Before concluding that the unit is at fault, make the following checks.

- Check if the rated input voltage is connected.
- Check if the wiring of input and output is correct.
- Check if the wire material is not too thin.
- Check if the output voltage control (V.ADJ) is properly adjusted.
- Check if the output current and output wattage do not over specification.
- Audible noise can be heard during Dynamic-Load operation.
- Audible noise can be heard when input voltage waveform is not sinusoidal wave.

10. Returns

Please contact your local sales office or visit our website to arrange return of any faulty product..

11. DRB-1 series UL508 Listed Condition

1) Wire Requirement

- Use minimum 75°C wire
- Use copper conductor only

Connector	Recommended Wire	Max. Torque
INPUT (L, N, FG)	solid and stranded, AWG12~24(wire strip length:4~5mm , 5mm max).	0.51N.m (4.5Lb.inch)
OUTPUT (+V, -V)	solid and stranded, AWG12~24(wire strip length:4~5mm , 5mm max).	0.51N.m (4.5Lb.inch)

- 2) For use in a Pollution degree 2 environment only
- 3) These products are considered for use where maximum surrounding air temperature does not exceed 70°C. When installing these products please refer to section 5-2 for deratings.
- 4) Indoor use only

TDK·Lambda

TDK-Lambda UK Ltd
Kingsley Avenue, Ilfracombe
Devon, EX34 8ES
Telephone - Sales and Service +44 (0)1271 856666
Head Office and Works +44 (0)1271 856600
Facsimile +44 (0)1271 864894
WEBSITE: www.uk.tdk-lambda.com