

# Allied Telesyn International

*CentreCOM*

***AT-4016F/ST***  
***AT-4016F/SC***

*Ethernet Switch with ATM Access*

***Installation Manual***

© Copyright 1996 Allied Telesyn International Corporation

All rights reserved. No part of this publication may be reproduced without prior written permission from Allied Telesyn International Corporation.

Allied Telesyn International Corporation reserves the right to make changes in specifications and other information contained in this document without prior written notice. The information provided herein is subject to change without notice. In no event shall Allied Telesyn International Corporation be liable for any incidental, special, indirect, or consequential damages whatsoever, including but not limited to lost profits, arising out of or related to this manual or the information contained herein, even if Allied Telesyn International Corporation has been advised of, known, or should have known, the possibility of such damages.

Trademarks: CentreCOM is a registered trademark of Allied Telesyn International Corporation. Ethernet is a registered trademark of Xerox Corporation. UNIX is a registered trademark of UNIX System Laboratories. Novell and NetWare are registered trademarks of Novell, Inc. Microsoft and MS-DOS are registered trademarks and LAN Manager and Windows for Workgroups are trademarks of Microsoft Corporation. 3Com is a registered trademark of 3Com. PC-NFS is a trademark of Sun Microsystems, Inc. PC/TCP is a registered trademark of FTP Software, Inc. DECnet is a registered trademark of Digital Equipment Corporation.

# Electrical Safety and Installation Requirements

---

## RADIATED ENERGY

### U.S. Federal Communications Commission

Note: This equipment has been tested and found to comply with the limits for a Class A digital device pursuant to Part 15 of the FCC Rules. These limits are designed to provide reasonable protection against harmful interference when the equipment is operated in a commercial environment. This equipment generates, uses, and can radiate radio frequency energy and, if not installed and used in accordance with this instruction manual, may cause harmful interference to radio communications. Operation of this equipment in a residential area is likely to cause harmful interference in which case the user will be required to correct the interference at his own expense.

Note: Modifications or changes not expressly approved by the manufacturer or the FCC can void your right to operate this equipment.

### Canadian Department of Communications

This Class A digital apparatus meets all requirements of the Canadian Interference-Causing Equipment Regulations.

Cet appareil numérique de la classe A respecte toutes les exigences du Règlement sur le matériel brouilleur du Canada.



## SAFETY

### ELECTRICAL NOTICES

#### WARNING: ELECTRIC SHOCK HAZARD

To prevent ELECTRIC shock, do not remove cover. No user-serviceable parts inside. This unit contains HAZARDOUS VOLTAGES and should only be opened by a trained and qualified technician. To avoid the possibility of ELECTRIC SHOCK, disconnect electric power to the product before connecting or disconnecting the LAN cables.



This is a "CLASS 1 LED PRODUCT"



### LIGHTNING DANGER

**DANGER:** DO NOT WORK on equipment or CABLES during periods of LIGHTNING ACTIVITY.

**CAUTION: POWER CORD IS USED AS A DISCONNECTION DEVICE.** TO DE-ENERGISE EQUIPMENT, disconnect the power cord.

## INSTALLATION

### ELECTRICAL—AUTO VOLTAGE ADJUSTMENT

This product will automatically adjust to any voltage between the ranges shown on the label.

### ELECTRICAL—TYPE CLASS 1 EQUIPMENT

**THIS EQUIPMENT MUST BE EARTHED.** Power plug must be connected to a properly wired earth ground socket outlet. An improperly wired socket outlet could place hazardous voltages on accessible metal parts.

### ELECTRICAL—CORD NOTICE

Use power cord, maximum 4.5 meters long, rated 6 amp minimum, 250V, made of HAR cordage molded IEC 320 connector on one end and on the other end a plug approved by the country of end use.

**CAUTION: Air vents must not be blocked** and must have free access to the room ambient air for cooling.

**CAUTION: DO NOT** detach rubber feet from the product unless an Allied Telesyn vertical mounting chassis is being used.

### Operating Temperature

This product is designed for a maximum ambient temperature of **40° C**.

**All Countries:** Install product in accordance with local and National Electrical Codes.

---

**NORMEN:** Dieses Produkt erfüllt die Anforderungen der nachfolgenden Normen.

### Hochfrequenzstörung

EN55022 Klasse A  
Störsicherheit EN50082-1

**WARNUNG:** Bei Verwendung zu Hause kann dieses Produkt Funkstörungen hervorrufen. In diesem Fall müßte der Anwender angemessene Gegenmaßnahmen ergreifen

### Störsicherheit

EN50082-1

### Elektrische Sicherheit

EN60950, UL1950, CSA 950



## SICHERHEIT

### ACHTUNG: GEFÄHRLICHE SPANNUNG

Das Gehäuse nicht öffnen. Das Gerät enthält keine vom Benutzer wartbaren Teile. Das Gerät steht unter Hochspannung und darf nur von qualifiziertem technischem Personal geöffnet werden. Vor Anschluß der LAN-Kabel, Gerät vom Netz trennen.



Das ist ein "LED Produkt der Klasse 1."

**GEFAHR DURCH BLITZSCHLAG**

**GEFAHR:** Keine Arbeiten am Gerät oder an den Kabeln während eines Gewitters ausführen.



**VORSICHT:** DAS NETZKABEL DIENST ZUM TRENNEN DER STROMVERSORGUNG. ZUR TRENNUNG VOM NETZ, KABEL AUS DER STECKDOSE ZIEHEN.

**INSTALLATION**

**AUTOMATISCHE SPANNUNGSEINSTELLUNG**

Dieses Gerät stellt sich automatisch auf die auf dem Etikett aufgeführten Spannungswerte ein.

**GERÄTEDER KLASSE 1**

**DIESE GERÄTE MÜSSEN GEERDET SEIN.** Der Netzstecker darf nur mit einer vorschriftsmäßig geerdeten Steckdose verbunden werden. Ein unvorschriftsmäßiger Anschluß kann die Metallteile des Gehäuses unter gefährliche elektrische Spannungen setzen.

**NETZKABEL**

Das Netzkabel sollte eine maximale Länge von 4,5 Metern, einen Nennwert von mindestens 6 A und 250 V haben, aus HAR-Material hergestellt und mit einer gepreßten, IEC 320 entsprechenden, Anschlußverbindung an einem Ende, und am anderen Ende mit einem im Land des Endverbrauchers geprüften Stecker ausgestattet sein.

**VORSICHT:** Die Entlüftungsöffnungen dürfen nicht versperrt sein und müssen zum Kühlen freien Zugang zur Raumluft haben.

**VORSICHT:** Die Gummifüße NICHT ENTFERNEN, außer bei Gebrauch des Allied Telesyn-Vertikalmontagegestells.

**BETRIEBSTEMPERATUR**

Dieses Produkt wurde für den Betrieb in einer Umgebungstemperatur von nicht mehr als 40° C entworfen.

**Alle Länder:** Installation muß örtlichen und nationalen elektrischen Vorschriften entsprechen.

**Radiofrekvens forstyrrelsesemission**

EN55022 Klasse A

**ADVARSEL:** I et hjemligt miljø kunne dette produkt forårsage radio forstyrrelse. Bliver det tilfældet, påkræves brugeren muligvis at tage tilstrækkelige foranstaltninger.

**Immunitet**

EN50082-1

**Elektrisk sikkerhed**

EN60950, UL1950, CSA 950



**SIKKERHED**

**ELEKTRISKE FORHOLDSREGLER**

**ADVARSEL: RISIKO FOR ELEKTRISK STØD**

For at forebygge ELEKTRISK stød, undlad at åbne apparatet. Der er ingen indre dele, der kan repareres af brugeren. Denne enhed indeholder LIVSFARLIGE STRØMSPÆNDINGER og bør kun åbnes af en uddannet og kvalificeret tekniker. For at undgå risiko for ELEKTRISK STØD, afbrydes den elektriske strøm til produktet, før LAN-kablerne monteres eller afmonteres.



Dette er et "Produkt under Klasse 1 LED"



**FARE UNDER UVEJR**

**FARE:** UNDLAD at arbejde på udstyr eller KABLER i perioder med LYNAKTIVITET.

**ADVARSEL:** DEN STRØMFØRENDE LEDNING BRUGES TIL AT AFBRYDE STRØMMEN. SKAL STRØMMEN TIL APPARATET AFBRYDES, tages ledningen ud af stikket.

**INSTALLATION**

**ELEKTRISK—AUTOMATISK SPÆNDINGSREGULERING**

Dette apparat vil automatisk tilpasse sig enhver spænding indenfor de værdier, der er angivet på etiketten.

**ELEKTRISK—KLASSE 1-UDSTYR**

**DETTE UDSTYR KRÆVER JORDFORBINDELSE.** Stikket skal være forbundet med en korrekt installeret jordforbunden stikkontakt. En ukorrekt installeret stikkontakt kan sætte livsfarlig spænding til tilgængelige metaldele.

**ELEKTRISK—LEDNING**

Anvend ledning af maksimum 4,5 meters længde, med en kapacitet på minimum 6 amp., 250 v, bestående af en IEC 320 connector med indstøbt HAR ledning i den ene ende og et stik i den anden ende godkendt der er af myndighederne i brugerlandet.

**ADVARSEL:** Ventilationsåbninger må ikke blokeres og skal have fri adgang til den omgivende luft i rummet for afkøling.

**ADVARSEL:** UNDLAD at fjerne gummisoklerne fra apparatet, med mindre der anvendes et Allied Telesyn vertikalt monteringsstel.

**BETJENINGSTEMPERATUR**

Dette apparat er konstrueret til en omgivende temperatur på maksimum 40 grader C.

**Alle Lande:** Installation af produktet skal ske i overensstemmelse med lokal og national lovgivning for elektriske installationer.

---

**RFI Emissie**  
EN55022 Klasse A

**WAARSCHUWING:** Binnenshuis kan dit product radiostoring veroorzaken, in welk geval de gebruiker verplicht kan worden om gepaste maatregelen te nemen.

**Immunititeit**  
EN50082-1

**Electrische Veiligheid**  
EN60950, UL1950, CSA 950



**VEILIGHEID**  
**WAARSCHUWINGEN MET BETREKKING TOT ELEKTRICITEIT**

**WAARSCHUWING: GEVAAR VOOR ELEKTRISCHE SCHOKKEN**

Gelieve het deksel niet te verwijderen, teneinde ELEKTRISCHE schokken te voorkomen. Binnenin bevinden zich geen onderdelen die door de gebruiker kunnen worden onderhouden. Dit toestel staat onder GEVAARLIJKE SPANNING en mag alleen worden geopend door een daartoe opgeleide en bevoegde technicus. Om het gevaar op ELEKTRISCHE SCHOKKEN te vermijden, moet u het toestel van de stroombron ontkoppelen alvorens de LAN-kabels te koppelen of ontkoppelen.



Dit is een "**Klasse 1 LED-produkt**"

**GEVAAR VOOR BLIKSEMINSLAG**

**GEVAAR:** NIET aan toestellen of KABELS WERKEN bij BLIKSEM.



**WAARSCHUWING: HET TOESTEL WORDT UITGESCHAKELD DOOR DE STROOMKABEL TE ONTKOPPELEN. OM HET TOESTEL STROOMLOOS TE MAKEN: de stroomkabel ontkoppelen.**

**INSTALLATIE**

**ELEKTRISCH—AUTOMATISCHE AANPASSING VAN DE SPANNING**

Dit toestel past zich automatisch aan elke spanning aan, tussen de waarden op het label vermeld.

**ELEKTRISCHE—TOESTELLEN VAN KLASSE 1**

DIT TOESTEL MOET GEAARD WORDEN. De stekker moet aangesloten zijn op een juist gearde contactdoos. Een onjuist gearde contactdoos kan de metalen onderdelen waarmee de gebruiker eventueel in aanraking komt onder gevaarlijke spanning stellen.

**ELEKTRISCHE—SNOEREN**

Gebruik een elektrisch snoer, maximum 4,5 meter lang, berekend voor ten minste 6 ampère, 250 V, uit HAR vervaardigd, met aan het ene uiteinde een gevormde IEC 320 stekker en aan het andere uiteinde een stekker die goedgekeurd is door het land waar het toestel zal worden gebruikt.

**WAARSCHUWING:** De ventilatiegaten mogen niet worden gesperd en moeten de omgevingslucht ongehinderd toelaten voor afkoeling.

**WAARSCHUWING:** De rubberen voetjes NIET van het produkt LOSMAKEN behalve wanneer een chassis voor verticale montage van Allied Telesyn wordt gebruikt.

**Bedrijfstemperatuur**

De omgevingstemperatuur voor dit produkt mag niet meer bedragen dan 40 graden Celsius.

**Alle landen:** het toestel installeren overeenkomstig de lokale en nationale elektrische voorschriften.

---

**NORMES :** ce produit est conforme aux normes de suivantes :

**Emission d'interférences radioélectriques**  
EN55022 Classe A

**MISE EN GARDE :** dans un environnement domestique, ce produit peut provoquer des interférences radioélectriques. Auquel cas, l'utilisateur devra prendre les mesures adéquates.

**Immunité**  
EN50082 - 1

**Sécurité électrique**  
EN60950, UL1950, CSA 950



**SECURITE**  
**INFORMATION SUR L'ELECTRICITE**

**AVERTISSEMENT: DANGER D'ELECTROCUTION**

Pour empêcher les dangers d'ELECTROCUTION, ne pas enlever le couvercle. L'équipement ne contient aucun élément réparable par l'utilisateur. Cet appareil comprend des TENSIONS DANGEREUSES et ne doit être ouvert que par un technicien dûment qualifié. Pour éviter tout risque d'ELECTROCUTION, débrancher l'appareil de la prise de courant avant de connecter ou de déconnecter les câbles LAN.



Ce produit est un « **Produit à diode électroluminescente de class 1.** »



**DANGER DE Foudre**

**DANGER:** NE PAS MANIER l'équipement ou les CABLES pendant les périodes d'activité orageuse.

**ATTENTION:** LE CORDON D'ALIMENTATION SERT DE MISE HORS CIRCUIT POUR COUPER L'ALIMENTATION DE L'APPAREIL, débranchez le cordon.

## INSTALLATION

### ELECTRICITE—REGLAGE DE TENSION AUTOMATIQUE

Ce produit peut s'ajuster automatiquement sur n'importe quelle tension comprise dans la plage indiquée sur le label.

### ELECTRICITE—EQUIPEMENT DE CLASSE 1

CET APPAREIL DOIT ETRE MIS A LA TERRE. La prise de courant doit être branchée dans une prise femelle correctement mise à la terre. Sinon, des tensions dangereuses risqueraient d'atteindre les pièces métalliques accessibles à l'utilisateur.

### ELECTRICITE—INFORMATION SUR LE CORDON

Utiliser un cordon secteur de 4,5 mètres de long maximum, calibré à 6 ampères minimum, 250V, et fabriqué en câblage HAR avec connecteur IEC 32C moulé à une extrémité et à l'autre extrémité, une prise de courant mâle répondant aux normes du pays d'utilisation.

**ATTENTION:** Ne pas bloquer les fentes d'aération, ce qui empêcherait l'air ambiant de circuler librement pour le refroidissement.

**ATTENTION:** NE PAS ôter les pattes d'attache en caoutchouc du produit, à moins d'utiliser un châssis de montage vertical Allied Telesyn.

### TEMPERATURE DE FONCTIONNEMENT

Ce produit est capable de tolérer une température ambiante maximum de 40 degrés Celsius

**Pour tous pays:** Installer le produit conformément aux normes électriques nationales et locales.

---

### Radioaaltojen häirintä

EN55022 Luokka A

**VAROITUS:** Kotiolosuhteissa tämä laite voi aiheuttaa radioaaltojen häiröitä, missä tapauksessa laitteen käyttäjän on mahdollisesti ryhdyttävä tarpeellisiin toimenpiteisiin.

### Kestävyys

EN50082-1

### Sähköturvallisuus

EN60950, UL1950, CSA 950



### TURVALISUUS

#### SÄHKÖÖN LIITTYVIÄ HUOMAUTUKSIA

##### VAROITUS: SÄHKÖISKUVAARA

Estääksesi SÄHKÖISKUN älä poista kantta. Sisällä ei ole käyttäjän huollettavissa olevia osia. Tämä laite sisältää VAARALLISIA JÄNNITTEITÄ ja sen voi avata vain koulutettu ja pätevä teknikko. Vältä äläkäsesi SÄHKÖISKUN mahdollisuuden katkaise sähkövirta tuotteeseen ennen kuin liität tai irrotat paikallisverkon (LAN) kaapelit.



Tämä on "ensimmäisen luokan valodiodituote."



### SALAMANISKUVAARA

HENGENVAARA: ÄLÄ TYÖSKENTELE laitteiden tai KAAPELEIDEN KANSSA SALAMOINNIN AIKANA.

**HUOMAUTUS:** VIRTajohtoa KÄYTETÄÄN VIRRANKATKAISULAITTEENA. VIRTA KATKAISTAAN irrottamalla virtajohto.

### ASENNUS

#### SÄHKÖ—AUTOMAATTINEN JÄNNITTEENSÄÄTÖ

Tämä tuote säätää automaattisesti mihin tahansa jännitteeseen ohjetarrassa annettujen arvojen välillä.

#### SÄHKÖ—TYYPPILUOKAN 1 LAITTEET

**TÄMÄ LAITE TÄYTY MAADOITTA.** Pistoke täytyy liittää kunnollisesti maadoitettuun pistorasiaan. Virheellisesti johdotettu pistorasia voi altistaa metalliosat vaarallisille jännitteille.

#### SÄHKÖ—JOHTOON LIITTYVÄ HUOMAUTUS

Käytä seuraavanlaista virtajohtoa: maksimipituus 4,5 metriä, minimiteho 6 ampeeria, 250 V, valmistettu HAR-johdostosta, muovattu IEC 320 -liitin toisessa päässä ja käyttömaassa hyväksytty pistoke toisessa päässä.

**HUOMAUTUS:** Ilmavaihtoreikiä ei pidä tukkia ja niillä täytyy olla vapaa yhteys ympäröivään huoneilmaan, jotta ilmanvaihto tapahtuisi.

**HUOMAUTUS:** ÄLÄ irroita kumijalkoja tuotteesta, ellei Allied Telesyn-pystykiinnitysalusta ole käytössä.

#### KÄYTTÖLÄMPÖTILA

Tämä tuote on suunniteltu ympäröivän ilman maksimilämpötilalle 40° C.

**Kaikki maat:** Asenna tuote paikallisten ja kansallisten sähköturvallisuusmääräysten mukaisesti.

---

**Emissione RFI (interferenza di radiofrequenza)**

EN55022 Classe

**AVVERTENZA:** in ambiente domestico questo prodotto potrebbe causare radio interferenza. In questo caso potrebbe richiedersi all'utente di prendere gli adeguati provvedimenti.

**Immunità**

EN50082-1

**Sicurezza elettrica**

EN60950, UL1950, CSA 950

**NORME DI SICUREZZA****AVVERTENZE ELETTRICHE****ATTENZIONE: PERICOLO DI SCOSSE ELETTRICHE**

Per evitare SCOSSE ELETTRICHE non asportare il coperchio. Le componenti interne non sono riparabili dall'utente. Questa unità ha TENSIONI PERICOLOSE e va aperta solamente da un tecnico specializzato e qualificato. Per evitare ogni possibilità di SCOSSE ELETTRICHE, interrompere l'alimentazione del dispositivo prima di collegare o staccare i cavi LAN.



Questo è un "**Prodotto con LED di Classe I.**"

**PERICOLO DI FULMINI**

**PERICOLO:** NON LAVORARE sul dispositivo o sui CAVI durante PRECIPITAZIONI TEMPORALESCHIE.

**ATTENZIONE:** IL CAVO DI ALIMENTAZIONE È USATO COME DISPOSITIVO DI DISATTIVAZIONE. PER TOGLIERE LA CORRENTE AL DISPOSITIVO staccare il cavo di alimentazione.

**INSTALLAZIONE****ELETTRICITÀ—REGOLAZIONE AUTOMATICA DELLA TENSIONE**

Questo prodotto regolerà automaticamente la tensione ad un valore compreso nella gamma indicata sull'etichetta.

**ELETTRICITÀ—DISPOSITIVI DI CLASSE 1**

**QUESTO DISPOSITIVO DEVE AVERE LA MESSA A TERRA.** La spina deve essere inserita in una presa di corrente specificamente dotata di messa a terra. Una presa non cablata in maniera corretta rischia di scaricare una tensione pericolosa su parti metalliche accessibili.

**ELETTRICITÀ—AVVERTENZA SUL CAVO**

Usare un cavo della lunghezza massima di metri 4,5, con capacità minima di 6 A, 250 V, di filo HAR, dotato di connettore stampato IEC 320 ad un'estremità e di spina approvata dal paese di destinazione all'altra.

**ATTENZIONE:** le prese d'aria non vanno ostruite e devono consentire il libero ricircolo dell'aria ambiente per il raffreddamento.

**ATTENZIONE:** NON staccare il piedino in gomma dal prodotto tranne qualora si utilizzi il telaio Allied Telesyn per il montaggio verticale.

**Temperatura di funzionamento**

Questo prodotto è concepito per una temperatura ambientale massima di 40 gradi centigradi.

**Tutti i paesi:** installare il prodotto in conformità alle vigenti normative elettriche nazionali.

---

**RFI stråling**

EN55022 Klasse A

**ADVARSEL:** Hvis dette produktet benyttes til privat bruk, kan produktet forårsake radioforstyrrelse. Hvis dette skjer, må brukeren ta de nødvendige forholdsregler.

**Immunitet**

EN50082-1

**Elektrisk sikkerhet**

EN60950, UL1950, CSA 950

**SIKKERHET****ELEKTRISKE MEDDELELSE****ADVARSEL: FARE FOR ELEKTRISK SJOKK**

For å unngå ELEKTRISK sjokk, må dekslet ikke tas av. Det finnes ingen deler som du kan bruke på innsiden. Denne enheten inneholder FARLIGE SPENNING, og må kun åpnes av en opplært, kvalifisert tekniker. For å unngå muligheten av ELEKTRISK SJOKK, må den elektriske strømmen til produktet være av når du slår LAN-ledninger av og på.



Dette er et "**klasse en LED produkt.**"

**FARE FOR LYNANTENNELSE**

**FARE:** MÅ IKKE BRUKES på utstyr eller ledninger mens LYN-AKTIVITET er i gang.



**FORSIKTIG:** STRØMLEDNINGEN BRUKES TIL Å SLÅ APPARATET AV. HVIS DU VIL DEAKTIVISERE UTSTYRET, må du fjerne strømledningen.

**INSTALLASJON****ELEKTRISK—AUTO SPENNINGSTILPASSING**

Dette produktet vil automatisk bli tilpasset hvilken som helst strømstilling i de områdene som vises på etiketten.

#### **ELEKTRISKE—TYPE 1. KLASSE UTSTYR**

DETTE UTSTYRET MÅ JORDES. Strømkontakten må være tilkopleet en korrekt jordet grunnstøpselkontakt. En støpselkontakt som ikke er jordet på rett måte, kan tilføre farlig spenning til lett tilgjengelige metalldeleer.

#### **ELEKTRISKE—MEDDELELSE OM LEDNINGER**

Bruk en strømledning av maksimal størrelse 4,5 m i lengde, vurdert for minst av 6 amp, 250V, fremstilt av HAR ledning IEC 320 koplingsstykke på den ene kanten og på den andre kanten en plugg som har blitt godkjent i det landet hvor den siste brukeren befinner seg.

**FORSIKTIG:** Luftventilene må ikke blokkeres og må ha fri tilgang til luft med romtemperatur for avkjøling.

**FORSIKTIG:** Gummiføttene må IKKE fjernes fra produktet med mindre en Allied Telesyn vertikal monteringschassis er i bruk.

#### **Driftstemperatur**

Dette produktet har blitt fremstilt til bruk med maksimum romtemperatur på 40 grader celsius.

**Alle land:** Produktet må installeres i samsvar med de lokale og nasjonale elektriske koder.

---

#### **Emissão de interferência de radiofrequência**

EN55022 Classe A

**AVISO:** Num ambiente doméstico este produto pode causar interferência na radiorecepção e, neste caso, pode ser necessário que o utente tome as medidas adequadas

#### **Imunidade**

EN50082-1

#### **Segurança Eléctrica**

EN60950, UL1950, CSA 950



#### **SEGURANÇA**

#### **AVISOS SOBRE CARACTERÍSTICAS ELÉTRICAS**

#### **ATENÇÃO: PERIGO DE CHOQUE ELÉTRICO**

Para evitar CHOQUE ELÉTRICO, não retire a tampa. Não contém peças que possam ser consertadas pelo usuário. Este aparelho contém VOLTAGENS PERIGOSAS e só deve ser aberto por um técnico qualificado e treinado. Para evitar a possibilidade de CHOQUE ELÉTRICO, desconecte o aparelho da fonte de energia elétrica antes de conectar e desconectar os cabos da LAN.



Este é um "**Produto Classe 1 LED.**"



#### **PERIGO DE CHOQUE CAUSADO POR RAIOS**

**PERIGO:** NÃO TRABALHE no equipamento ou nos CABOS durante períodos suscetíveis de QUEDAS DE RAIOS.

**CUIDADO:** O CABO DE ALIMENTAÇÃO É UTILIZADO COMO UM DISPOSITIVO DE DESCONEXÃO. PARA DESELETRIFICAR O EQUIPAMENTO desconecte o cabo de alimentação.

#### **INSTALAÇÃO**

#### **ELÉTRICO—AJUSTE AUTOMÁTICO DE VOLTAGEM**

Este produto ajustar-se-á automaticamente a qualquer voltagem que esteja dentro dos limites indicados no rótulo.

#### **ELÉTRICO—EQUIPAMENTOS DO TIPO CLASSE 1**

DEVE SER FEITA LIGAÇÃO DE FIO TERRA PARA ESTE EQUIPAMENTO. O plugue deve ser conectado a uma tomada com ligação de fio terra. Tomadas sem ligação de fio terra podem transmitir voltagens perigosas a peças metálicas expostas.

#### **ELÉTRICO—AVISO SOBRE O CABO DE ALIMENTAÇÃO**

Use cabo de alimentação com comprimento máximo de 4,5 metros, com uma capacidade mínima de 6 amp e 250 V, fabricado de material para cabo HAR com conector moldado IEC 320 em uma extremidade e, na outra extremidade, um plugue aprovado para uso no país em questão.

**CUIDADO:** As entradas de ar não devem ser bloqueadas e devem ter acesso livre ao ar ambiente para arrefecimento adequado do aparelho.

**CUIDADO: NÃO RETIRE** os calços de borracha do produto a menos que esteja sendo usado um chassis de montagem vertical Allied Telesyn.

#### **TEMPERATURA DE FUNCIONAMENTO**

Este produto foi projetado para uma temperatura ambiente máxima de 40 graus centígrados.

**Todos os países:** Instale o produto de acordo com as normas federais e locais para instalações elétricas.



---

**Emisión RFI**  
EN55022 Clase A

**ADVERTENCIA:** en un entorno doméstico, este producto puede causar radiointerferencias, en cuyo caso, puede requerirse del usuario que tome las medidas que sean convenientes al respecto.

**Inmunidad**  
EN50082-1

**Seguridad eléctrica**  
EN60950, UL1950, CSA 950



**SEGURIDAD**  
**AVISOS ELECTRICOS**  
**ADVERTENCIA: PELIGRO DE ELECTROCHOQUE**

Para evitar un ELECTROCHOQUE, no quite la tapa. No hay ningún componente en el interior al cual puede prestar servicio el usuario. Esta unidad contiene VOLTAJES PELIGROSOS y sólo deberá abrirla un técnico entrenado y calificado. Para evitar la posibilidad de ELECTROCHOQUE desconecte la corriente eléctrica que llega al producto antes de conectar o desconectar los cables LAN.



Este es un "producto de diodo luminiscente (LED) clase 1."



**PELIGRO DE RAYOS**

**PELIGRO:** NO REALICE NINGUN TIPO DE TRABAJO O CONEXION en los equipos o en LOS CABLES durante TORMENTAS DE RAYOS.

**ATENCION:** EL CABLE DE ALIMENTACION SE USA COMO UN DISPOSITIVO DE DESCONEXION. PARA DESACTIVAR EL EQUIPO, desconecte el cable de alimentación.

**INSTALACION**

**ELECTRICO—AUTO-AJUSTE DE TENSION**

Este producto se ajustará automáticamente a cualquier tensión entre los valores máximos y mínimos indicados en la etiqueta.

**ELECTRICO—EQUIPO DEL TIPO CLASE 1**

ESTE EQUIPO TIENE QUE TENER CONEXION A TIERRA. El cable tiene que conectarse a un enchufe con tierra debidamente instalado. Un enchufe que no está correctamente instalado podría ocasionar tensiones peligrosas en las partes metálicas están expuestas.

**ELECTRICO—ADVERTENCIA SOBRE EL CABLE**

Use un cable eléctrico con un máximo de 4, 5 metros de largo, con una capacidad mínima de 6 amperios, 250 V, hecho de cable HAR, con el conector moldeado IEC 320 en un extremo y con un enchufe que está aprobado por el país de uso final en el otro.

**ATENCION:** Las aberturas para ventilación no deberán bloquearse y deberán tener acceso libre al aire ambiental de la sala para su enfriamiento.

**ATENCION:** NO separe las patas de goma del producto a menos que se esté usando un chasis de montaje vertical de Allied Telesyn.

**Temperatura requerida para la operación**

Este producto está diseñado para una temperatura ambiental máxima de 40 grados C.

**Para todos los países:** Monte el producto de acuerdo con los Códigos Eléctricos locales y nacionales.

---

**Radiostörning**  
EN55022 Klass A \

**WARNING:** Denna produkt kan ge upphov till radiostörningar i hemmet, vilket kan tvinga användaren till att vidtaga erforderliga åtgärder.

**Immunitet**  
EN50082-1

**Elsäkerhet**  
EN60950, UL1950, CSA 950



**SÄKERHET**  
**TILLKÄNNAGIVANDEN BETRÄFFANDE ELEKTRICITETSRIK:**  
**RISK FÖR ELEKTRISK STÖT**

För att undvika ELEKTRISK stöt, ta ej av locket. Det finns inga delar inuti som behöver underhållas. Denna apparat är under HÖGSPÄNNING och får endast öppnas av en utbildad kvalificerad tekniker. För att undvika ELEKTRISK STÖT, koppla ifrån produktens strömanslutning innan LAN-kablarna ansluts eller kopplas ur.



Detta är en "Klass 1 lysdiodprodukt"

**FARA FÖR BLIXTNEDSLAG**

**FARA:** ARBETA EJ på utrustningen eller kablarna vid ÅSKVÄDER.



**WARNING:** NÄTKABELN ANVÄNDS SOM STRÖMBRYTARE FÖR ATT KOPPLA FRÅN STRÖMMEN, dra ur nätkabeln.

**INSTALLATION**

**ELEKTRISKT—AUTOMATISK SPÄNNINGSJUSTERING**

Denna produkt justeras automatiskt till alla spänningar inom omfånget som indikeras på produktens märkning.

**ELEKTRISKT—TYP KLASS 1 UTRUSTNING**

DENNA UTRUSTNING MÅSTE VARA JORDAD. Nätkabeln måste vara ansluten till ett ordentligt jordat uttag. Ett felaktigt uttag kan göra att närliggande metalldelar utsätts för högspänning. Apparaten skall anslutas till jordat uttag, när den ansluts till ett nätverk.

**ELEKTRISKT—ANMÄRKNING BETRÄFFANDE KABELN**

Använd en kabel med maximum längd 4,5 meter och minimum 6 amp nominal, 250V, av HAR kabelfabrikat med ett specialutformat IEC 320-kontaktdon i ena änden och i den andra en plugg som godkänts i landet där produkten används.

**VARNING:** Luftventilerna får ej blockeras och måste ha fri tillgång till omgivande rumsluft för avsvälning.

**VARNING:** Ta ej bort gummifötterna från produkten om inte ett Allied Telesyn vertikalt monteringschassi används.

**DRIFTSTEMPERATUR**

Denna produkt är konstruerad för rumstemperatur ej överstigande 40 grader Celsius.

**Alla länder:** Installera produkten i enlighet med lokala och statliga bestämmelser för elektrisk utrustning.

# Table of Contents

---

## Electrical Safety and Installation Requirements

### About This Manual

Background .....	xiii
Document Conventions .....	xiv
Related Documentation .....	xiv
Contacting ATI Technical Support .....	xv
Phone Numbers .....	xv
Bulletin Board Services .....	xvi
Internet Mail .....	xvi
CompuServe Forum .....	xvi
World Wide Web .....	xvi
FTP Server .....	xvi

## Chapter 1

### Overview

AT-4016F Ethernet Switch with ATM Access .....	1
Features .....	2
ATI's Solution .....	3
MIB Support .....	6
Ethernet-to-Ethernet Switch .....	6
ATM Addresses .....	6
Network Prefix .....	6
Selector Byte .....	7
MAC Address .....	7
Two Modes of Ethernet Switching .....	8
Cut-Through .....	8
Store-and-Forward .....	8
Bridging .....	9
Bridge Address Table .....	9
AT-4016F User Topology .....	10
AT-4016F/ST .....	11
AT-4016F/SC .....	12
FOIRL, 10Base-FL Wiring Specifications .....	13
Duplex Fiber Optic Cable .....	13
Configuration Rules .....	14
Power Supply .....	14
Network Management .....	14
Upgrading Software .....	14

**Chapter 2**

**Installation**

Site Preparation . . . . . 15  
     Location . . . . . 15  
     Ventilation . . . . . 15  
     Power . . . . . 15  
 Installing the AT-4016F ATM Ethernet Switch . . . . . 16  
 Installing the Redundant Power Supplies . . . . . 17  
 Media Module Installation . . . . . 18

**Chapter 3**

**Connectivity**

Front Panel . . . . . 19  
 Back Panel . . . . . 20  
 AT-4016F Ports . . . . . 21  
     Station Ports . . . . . 21  
     RS232 Terminal Port . . . . . 21  
     PCMCIA Interface . . . . . 21  
     ATM Media Interface . . . . . 21  
 LED Displays . . . . . 22  
     System Status LEDs . . . . . 22  
     Power Supply LEDs . . . . . 23  
     Fiber Optic Port LEDs . . . . . 24  
 ATM Interface LEDs . . . . . 25  
     ATM Port LEDs . . . . . 25  
     Alarms LEDs . . . . . 25  
     LOOP LEDs . . . . . 25  
     ATM Media Module LEDs . . . . . 26  
 Reset Switch . . . . . 27

**Chapter 4**

**Troubleshooting**

Troubleshooting the Installation . . . . . 29  
 LED Indicators . . . . . 29  
     Power Supply LEDs . . . . . 29  
     ATM Media Module LEDs . . . . . 29

**Appendix A**

**Glossary** . . . . .

**Appendix B**

**Technical Support Fax Order** . . . . . 37  
 Incident Summary . . . . . 37

**Appendix C**

**Installation Manual Feedback** . . . . . 39

**Appendix D**

**Where To Find Us** . . . . . 41

**Appendix E**

**Index** . . . . . 43

# About This Manual

---

## Background

---

This manual assumes that you, the user, are familiar with the fundamentals of Asynchronous Transfer Mode (ATM) technology and the operation of switching bridges. If you are unsure about some of the features included in this document, we refer you to the reference documentation noted in this preface under the subheading “Related Documentation.”

The contents of each chapter are described below.

- ❑ Chapter 1, “Overview” describes both the AT-4016F/SC and AT-4016F/ST hardware platforms. These platforms are identical in that they combine 10 Mbps of *dedicated* Ethernet-to-Ethernet bandwidth on each of sixteen (16) FOIRL, 10BASE-FL, Fiber Optic ports with a 155 Mbps Asynchronous Transfer Mode (ATM) Fiber Optic port for Ethernet-to-ATM connectivity. They differ only by the type of Ethernet-to-Ethernet front panel connector (SC or ST).
- ❑ Chapter 2, “Installation” details how to install an AT-4016F in a standalone configuration. It also describes the redundant, dual power-supply and ATM Media Modules.
- ❑ Chapter 3, “Connectivity” describes network hardware functions. The first two sections cover the layout of the front and back panels. The rest of the chapter covers the functionality of the different components: connectors, indicators and switches.
- ❑ Chapter 4, “Troubleshooting” tells you how to troubleshoot the installation as well as how to use LED indicators towards the resolution of problems.

## Document Conventions

---

The following conventions are used in this manual:

Commands, prompts, and information displayed by the computer appear in Courier typeface, for example:

```
Current Number of Learned Addresses: 133
Number of Defined Filters: 4
```

Information *that you enter* appears in Courier bold typeface, for example:

```
AT-4016F >status
```

Information that you *need to enter with a command* is enclosed in angle brackets < >. For example, you must enter a port number and an IP address to execute the `ipaddr <port #> <IP address>` command. Note that the IP address shown below is for illustration only and not meant to represent your actual IP address.

```
AT-4016F <ipaddr 6 192.138.217.40>
```

Field value options appear in bold typeface. For example, an AT-4016F filter type can be either **Entry** or **Exit**.

---

Note

---

A note provides additional information about, or possible consequence of, a specific action you can perform.

---

## Related Documentation

---

You may find the following networking reference material helpful:

- ❑ *Interconnections, Bridges and Routers*, Radia Perlman, Addison Wesley © 1992.
- ❑ *Internetworking with TCP/IP: Principles, Protocols, and Architecture* (2nd edition), Volumes I and II, Douglas Comer, Prentice Hall © 1991.
- ❑ *The Simple Book, An Introduction to Management of TCP/IP-based internets*, Marshall T. Rose, Prentice Hall © Second Edition, 1994.
- ❑ ATM Forum contributions are only available to Principal Members of the ATM Forum although published Forum specifications are available for purchase. Call the ATM Forum at 415.578.6860, fax server at 415.525.0182, or send e-mail to [af-info@atmforum.com](mailto:af-info@atmforum.com) for details about ATM Forum membership.
- ❑ Internet RFCs can be obtained through anonymous FTP or e-mail to [rfc-info@ISI.EDU](mailto:rfc-info@ISI.EDU) with the message: `help: ways_to_get_rfc`

- Internet drafts are available by anonymous FTP. Internet draft directories are located at:
  - US East Coast: *ds.internic.net*
  - US West Coast: *ftp.isi.edu*
  - Europe: *nic.nordu.net*
  - Pacific Rim: *nunnari.oz.au*
- ATM documentation is also available through Phillips Publishing International: (301) 424-3700 or (703) 281-1135

## Contacting ATI Technical Support

---

Problems? You can contact ATI's Technical Support staff by:

- Telephone
- Bulletin board services
- Electronic mail via the Internet
- CompuServe forum

When you contact Technical Support, you should have the following information available:

- Serial number of your AT-4016F
- Power-up test codes, if any
- Diagnostic test codes, if any

### Phone Numbers

Commercial telephone service is available Monday through Friday from 6:30 AM to 5:00 PM PST:

**1 (800) 428-4835  
(United States)**

The FAX number is:

**(206) 481-3790**

For telephone numbers outside of the United States and Canada, contact your reseller or regional ATI office.

## Bulletin Board Services

A bulletin board is available. The number is:

**(206) 483-7979**

Modem settings for the bulletin board is: 9600 baud; 8 bits; no parity; 1 stop bit.

The process is straightforward: Once the BBS is accessed, it requests that you register either as a new user or as a current user. It then provides instructions on the various features and functions available. This is followed by a list and description of all available technical notes and files that can be downloaded.

## Internet Mail

You can send electronic mail via the Internet to:

**tech\_support@centre.com**

## CompuServe Forum

ATI has a forum on CompuServe. You can reach us by typing **GO ALLIED** at the CompuServe prompt (!).

## World Wide Web

You can access Allied Telesyn at our new Web Site using the following:

**http://www.alliedtelesyn.com**

## FTP Server

Allied Telesyn has Internet access to an FTP Server in Bothell, WA., for driver and Readme files on our adapter cards and managed products. The server can be accessed through your Internet connection as follows (note — use lower case letters):

Address	gateway.centre.com [lowercase letters]
Login	anonymous [lowercase letters]
Password	your e-mail address [requested by the server when you login]



# Chapter 1

## Overview

---

This manual describes the AT-4016F hardware platform and provides installation procedures and connectivity information. For information on network management and firmware, see the separate *CentreCOM AT-4016F Ethernet Switch with ATM Access — Operations Manual* which is shipped with each system.

### AT-4016F Ethernet Switch with ATM Access

---

This manual describes both the AT-4016F/SC and the AT-4016F/ST hardware platforms. While these platforms are identical in form and function they differ only by the type of Ethernet-to-Ethernet front panel connector.

That is, in addition to the Ethernet-to-ATM fiber optic interface, you have the option of using either Straight Tip (ST) or Subscriber Channel (SC) fiber optic Ethernet-to-Ethernet connectors. Figure 1 shows both connectors.

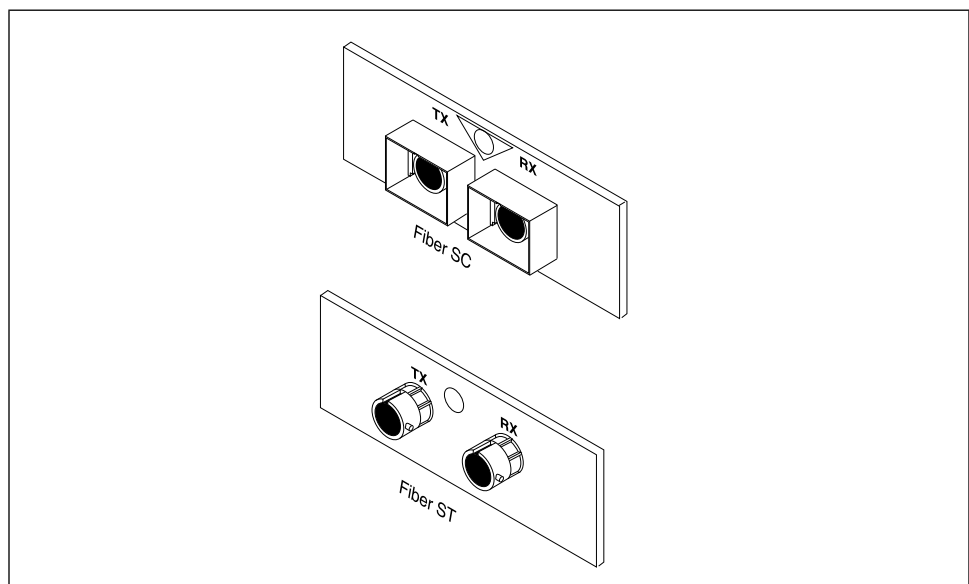

Figure 1: ST and SC Connectors

## Features

---

The following features are fully implemented

- ❑ “Hot swappable,” dual-redundant, load-sharing, modular power supplies
- ❑ 16 Fiber Optic — either SC or ST connectors — ports
- ❑ ATM media interface, configurable by means of removable media cards in several different media types
- ❑ RS232C ASYNC ASCII terminal port for local network management
- ❑ Recessed reset switch
- ❑ Stand-alone or 19-inch rack mount chassis options
- ❑ Software upgradeability through a PCMCIA memory card
- ❑ Comprehensive diagnostic LEDs
- ❑ Separate Ethernet segment availability, with one or multiple DTEs on all 16 switched ports
- ❑ Plug-in 155 Mbps Synchronous Optical Network (SONET) OC-3c or SDH STM-1 ATM physical media modules that allow various media choices:
  - multimode fiber/SC connectors
  - single mode fiber/SC connectors
  - Level 5 UTP/100  $\Omega$  STP
- ❑ Signaling between AT-4016TR and ATM switches in conformance with ATM Forum UNI 3.0 Specifications (Firmware dependent)

---

Note

---

Note that UNI 3.0 protocols cannot communicate with UNI 3.1 protocols due to differences in signaling. Therefore, ensure that all your equipment is at the same UNI standard.

---

Table 1 summarizes both versions of ATI's Fiber Optic AT-4016F Switch.

**Table 1:** AT-4016F Multimode Fiber Options

Model Number	Port Count	Media/Connector Type
AT-4016F (ST)	16	Fiber Optic (FOIRL, 10Base-FL) with Straight Tip (ST) connectors
AT-4016F (SC)	16	Fiber Optic (FOIRL, 10Base-FL) with Subscriber Channel (SC) connectors

## ATI's Solution

---

In the past, a legacy Ethernet-to-Ethernet switch partially resolved fundamental bandwidth congestion problems by assigning each node to a unique segment.

That was yesterday. Unfortunately, legacy Ethernet-to-Ethernet switching is not a total solution to bandwidth congestion when it originates from the backbone or if you (and others at the same time) access a server or data base which is outside your local network.

For example, bandwidth congestion — and subsequent degradation of network throughput — will occur if just a single node in the network is either the source, or destination, of excessive traffic.

ATI's solution is straightforward.

First. If your LAN is out of bandwidth then you can use your AT-4016F to convert your legacy, shared-media traffic to a dedicated 10 Mbps for each port.

Next. Use ATM functionality to connect traffic to a server or backbone (at up to 155 Mbps in this case). Once you have done this, you will have eliminated the focused load problem associated with other switching technologies that force the server to run at the same rate as the client devices.

The advantage of this approach is that you only have to “upgrade” those devices that actually need the increased bandwidth (like the server).

Figure 2 shows the front panel of an AT-4016F/SC. It is presented here as a review of the positioning of the relevant ports. A full discussion of the functions, LEDs and other features of this switch will be discussed later.

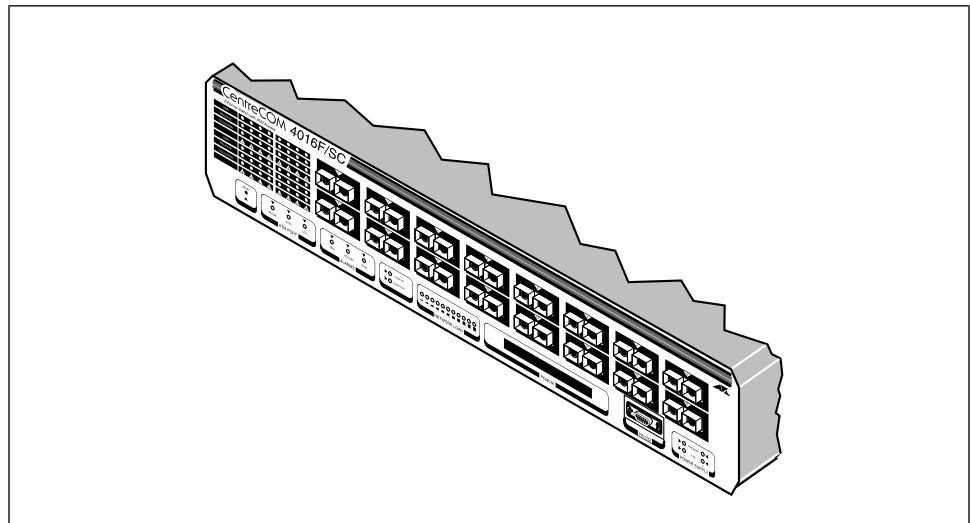

Figure 2: AT-4016F/SC Front Panel

Figure 3 shows the front panel of an AT-4016F/ST.

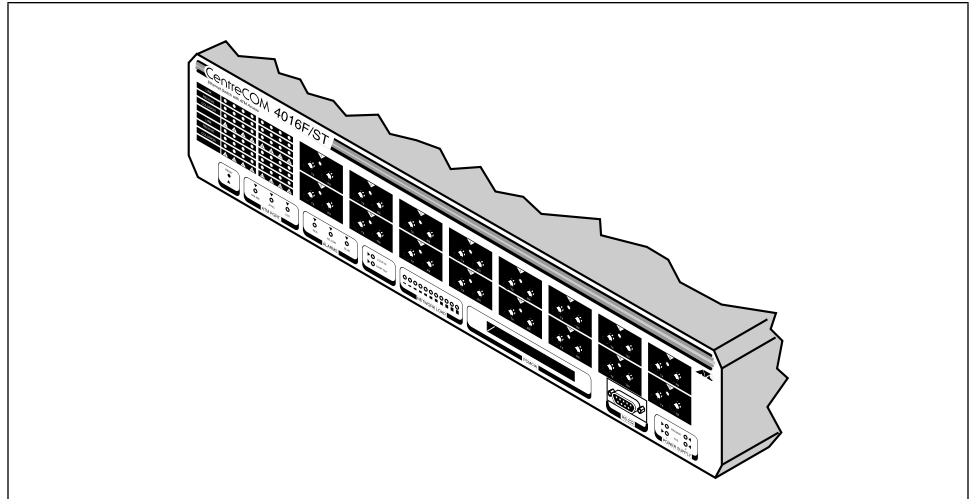

Figure 3: AT-4016F/ST Front Panel

Figure 4 shows the Ethernet-to-ATM modular media interface which is located on the back panel.

Both the AT-4016F/SC and the AT-4016F/ST have identical back panels.

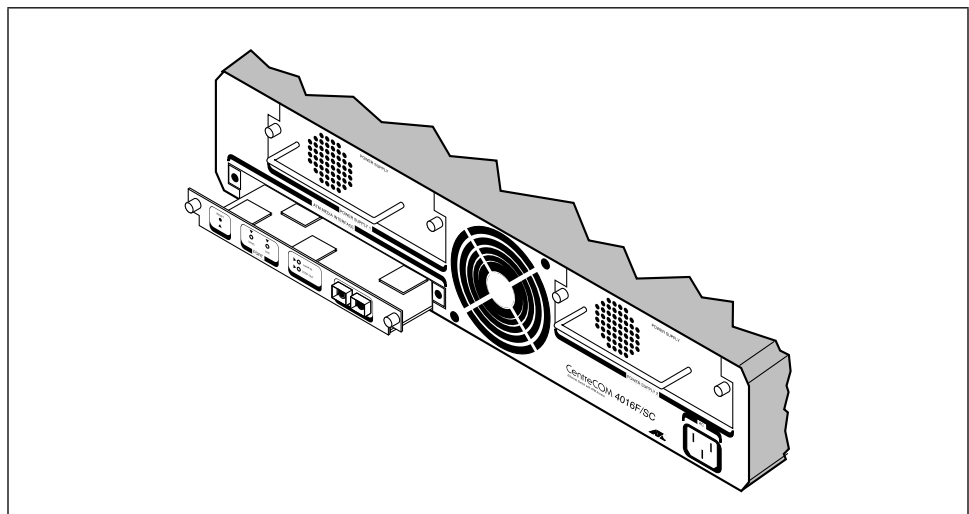

Figure 4: ATM Media Interface

Figure 5 shows a close-up of the ATM Media Module faceplate using an SC connector.

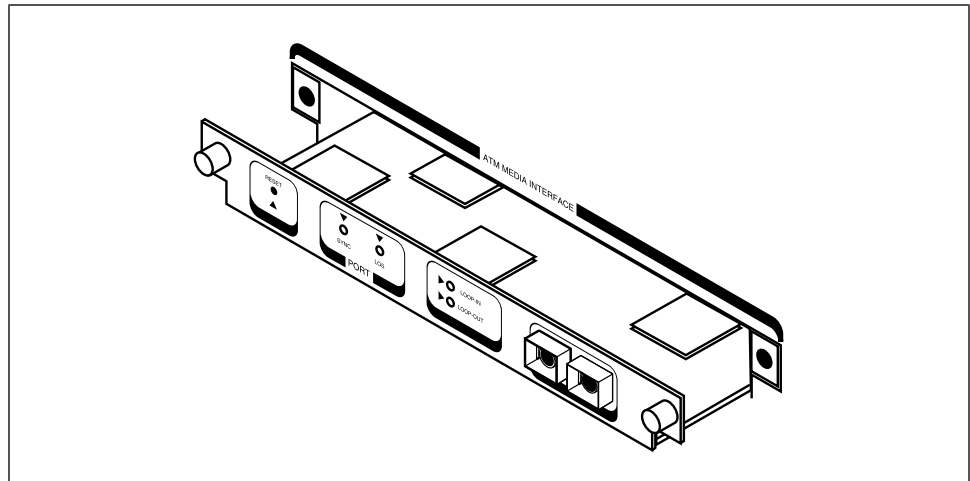

Figure 5: ATM Faceplate

Without a media module installed, or installed but not used, the AT-4016F operates as a standalone Ethernet switch.

When ordered factory-installed, the media module version is indicated by the third digit in the model name suffix. You can also order additional ATM Physical Media Modules separately for different media requirements.

Table 2 shows the suffixes and separate model numbers for ATM Media Modules.

Table 2: ATM Media Modules

AT-4016F Model Suffix	Media Module Model	Description
0	—	ATM slot (i.e., the AT-4016F acts as an Ethernet switch without ATM connectivity)
2	AT-4002	155 Mbps OC-3c/STM-1 multimode optical media module
3	AT-4003 <sup>1</sup>	155 Mbps OC-3c/STM-1 twisted pair media module
5	AT-4005 <sup>2</sup>	155 Mbps OC-3c/STM-1 single mode optical media module

1. Available 2Q96

2. Available 3Q96

## MIB Support

The following Management Information Base (MIB) protocols are supported by ATI's AT-4016F Omega Management Software.

- SNMP MIB2 (RFC 1213)
- Ethernet MIB (RFC 1643)
- Partial Bridge MIB (RFC 1493)
- ATM Forum ILMI MIB

## Ethernet-to-Ethernet Switch

---

Your AT-4016F combines Ethernet-to-Ethernet device switching with Ethernet-to-ATM backbone/server connectivity. As such, it provides user-programmable capabilities that can screen data packets based on several user-defined criteria including port (or protocol) criteria.

Additional user-programmable capabilities provide:

- Enhanced network security
- Improved network performance
- Greater network traffic control

For example, your switch can be programmed to restrict access to a specific network segment or device, or to limit multicast traffic. In short, the user-programmable capabilities of your switch can be used to establish virtual LANs which, in turn, allows physical segments to be dynamically assigned to logical workgroups.

## ATM Addresses

---

ELAN membership requires ATM addresses.

That is, ATM addresses are used by each device attached to your LEC to register and acknowledge membership to an ELAN. Specifically, ELAN assignment is based upon an address registration which consists of a network prefix, a Media Access Control (MAC) address (also known as Ethernet addresses) and a selector byte.

[network prefix] [MAC address] [selector byte]

### Network Prefix

The network prefix is determined through the ILMI protocol.

**[network prefix]** [MAC address] [selector byte]

During the AT-4016F power on cycle, internal tests are automatically run to test the integrity of the CPU and memory. After the tests are successfully completed, a request is sent to the ATM switch for a network prefix assignment.

## Selector Byte

The selector byte is used to denote specific ELAN membership.

[network prefix] [MAC address] [**selector byte**]

Selector bytes consist of integers ranging from 00 to 64 and includes a “Super LEC.”

For example, a complete ATM port address will resemble of the following:

[network prefix] [MAC address] [00] — The “Super LEC”

[network prefix] [MAC address] [01] — LEC for ELAN #1

[network prefix] [MAC address] [02] — LEC for ELAN #2

\*

\*\*

\*\*\*

[network prefix] [MAC address] [0x40] — LEC for ELAN #64

These ATM addresses are used to join ELANs 01 through 64 (hex 40).

## MAC Address

A basic MAC address has been assigned to each switch by the manufacturer.

[network prefix] [**MAC address**] [selector byte]

If you are unsure of the base MAC address, it can be found either as a decal above the RS232 port and/or on the Omega **Diagnostics** menu.

Figure 6 shows the location of the MAC address label on the front panel.

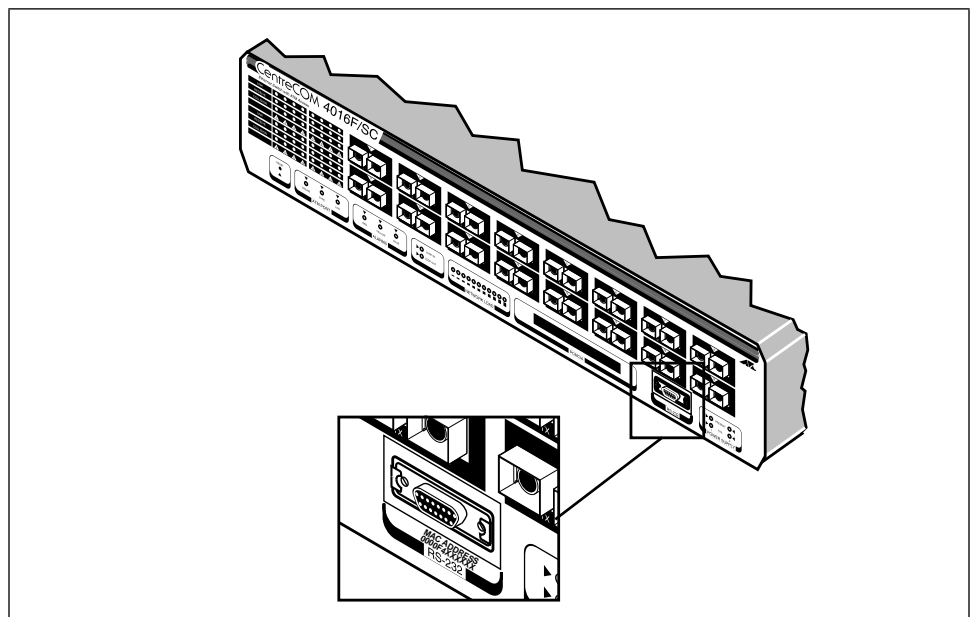

Figure 6: AT-4016F MAC Address Label

Each ATM MAC address is created by adding the port number to the basic AT-4016F MAC address.

Since the AT-4016F has 16 ports there are 16 MAC addresses:

**Port #1 - [basic MAC address + 01]**

**Port #2 - [basic MAC address + 02]**

\*  
\*\*  
\*\*\*

**Port #16 - [basic MAC address +16]**

## Two Modes of Ethernet Switching

---

There are two popular methods to forward information: cut-through and store-and-forward. Although your AT-4016F employs store-and-forward as the default, you can also choose cut-through.

### Cut-Through

In a cut-through system, the device starts to forward the incoming packet while the packet is still being received on the inbound link.

Cut-through switching requires software that can both look at the start of the packet and determine which outbound link is to be used to forward the packet. Cut-through does not check for Cyclic Redundancy Check (CRC) errors before forwarding a packet.

### Store-and-Forward

Store-and-forward means that your AT-4016F stores the incoming packet as it receives it until it has the entire packet and then forwards it.

Store-and-forward switching, performed at the MAC layer, not only checks for a valid CRC before forwarding a packet, but allows your AT-4016F to temporarily store packets until network resources, typically an unused link, are available for forwarding. This allows complete error checking until the entire packet is received correctly and limits the amount of time between when a device requests access to the network and when it is granted permission to transmit. Full store-and-forward switching, therefore, ensures data integrity, thus preventing network error conditions from being generated throughout the network.

On the other hand, in a store-and-forward system, every device in the path from the sender of the packet to the packet's receiver adds a small delay due to the time spent storing the packet before forwarding it.



## Bridging

---

Your AT-4016F acts as a transparent bridge to the Ethernet ports and the ATM interface. As such, it learns the source MAC address of all incoming packets and ages out devices which have not been heard for a period of time.

Bridging involves a forwarding table with a maximum storage capacity of 2,048 MAC address. These addresses are associated with all devices that have been detected recently either from Ethernet ports or the ATM interface.

Each virtual LAN uses a unique bridge. Therefore, relayed data within a virtual LAN is segregated from relayed data in other virtual LANs and broadcast traffic is isolated within each virtual LAN, even if the virtual LAN resides in the same AT-4016F.

Since the AT-4016F switch automatically routes traffic onto virtual LANs, you can only connect virtual LANs either to each other or to external routers.

### Bridge Address Table

Your AT-4016F checks all incoming packets from each port for their destination address against a Bridge Address Table. If a packet's destination address is not on the same network segment as the originating packet, the AT-4016F forwards the packet to the network segment associated with that destination address. However, if the packet's source and destination address are on the same network segment, known as local traffic, the packet is automatically discarded (ignored).

The AT-4016F creates and maintains a dynamic database of addresses which are stored in a Bridge Address Table. Port information entries in the Bridge Address Table are, in turn, used as a basis from which to compare and examine every packet to determine its source address, segment origin and port information.

If a packet's MAC address is not already stored in the Bridge Address Table, the AT-4016F adds the learned address, the associated port number and a timer value that indicates the age of the dynamic Bridge Address Table entry. Consequently, the AT-4016F knows the address and associated port number the next time it sees that address. By using the information stored in the Bridge Address Table, the AT-4016F is able to quickly forward each packet to the correct port.

The AT-4016F learns addresses from all packets. When devices are added to the network, removed from it, or relocated, you do not have to reconfigure your AT-4016F. Your AT-4016F automatically learns all addresses.

An address stored in the Bridge Address Table is discarded if there is no activity from that address after a configured length of time (the default is five minutes). This aging process ensures that the Bridge Address Table is not only continually updated but does not grow too large.

Each entry which is automatically entered (a dynamic entry) includes:

- ❑ An Ethernet MAC address
- ❑ The port number of the LAN on which the address resides
- ❑ The age of the entry
- ❑ ELAN/VLAN membership

Each entry which is manually entered (a static entry) contains the same information as a dynamic entry, except that a static entry is not aged.

The AT-4016F can store up to 2,048 static and dynamic entries in its Bridge Address Table.

## AT-4016F User Topology

As defined by the ATM Forum, the AT-4016F offers interoperability with Ethernet hosts and other LAN Emulation Clients (LECs) through a LAN Emulation User to Network Interface (LUNI).

Figure 7 shows an example linking many LANs across an ATM network. In this example, even if all AT-4016F switches are in separate locations, all the computing resources connected to them behave as if they are co-located on the same LAN.

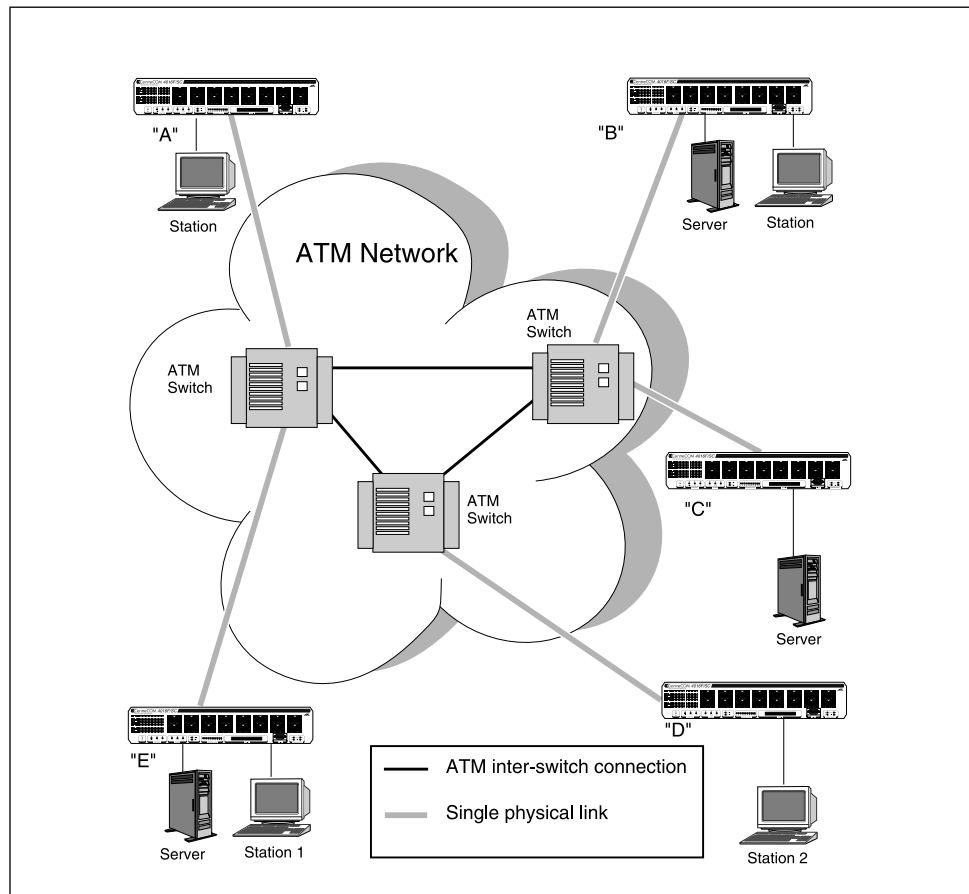

Figure 7: ATM Implementation

## AT-4016F/ST

The AT-4016F/ST has Straight Tip (ST) connectors which mate through a two-pin, bayonet-style interface.

ST connectors are popular simply because they have less attenuation and less vulnerability to human error than previous fiber optic connectors such as a Sub Miniature Assembly (SMA).

On the other hand, if your existing (usually older) networking environment uses SMA (or Biconic) connectors, a commercially available ST-SMA hybrid cable allows easy conversion from one type of connector to the other. This cable is a one-meter duplex fiber optic cable with ST connectors on one end and SMA connectors on the other.

Figure 8 shows the front panel of an AT-4016F/ST.

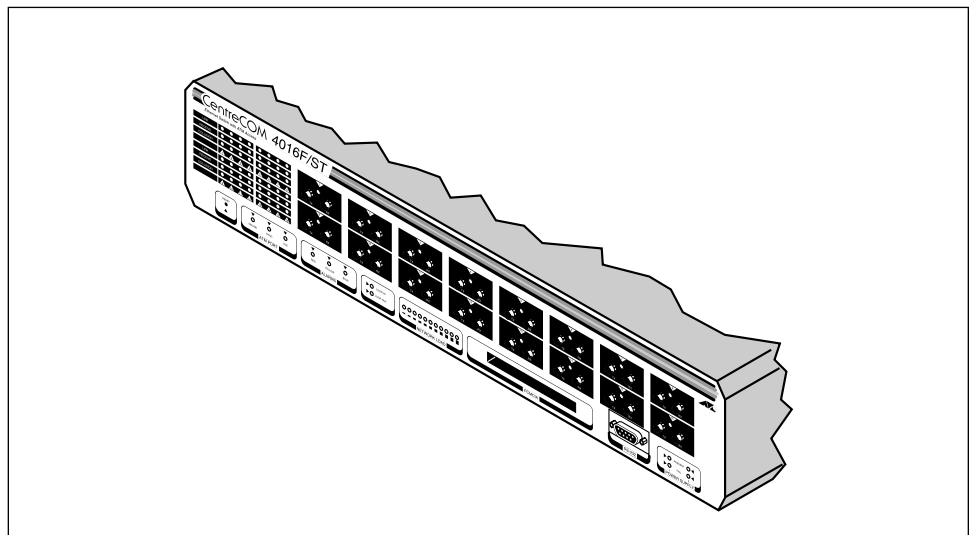

Figure 8: AT-4016F/ST Front Panel

Figure 9 shows an ST connector. This connector uses a spring loaded twist and lock coupling similar to conventional BNC connectors that are used with coaxial cabling.

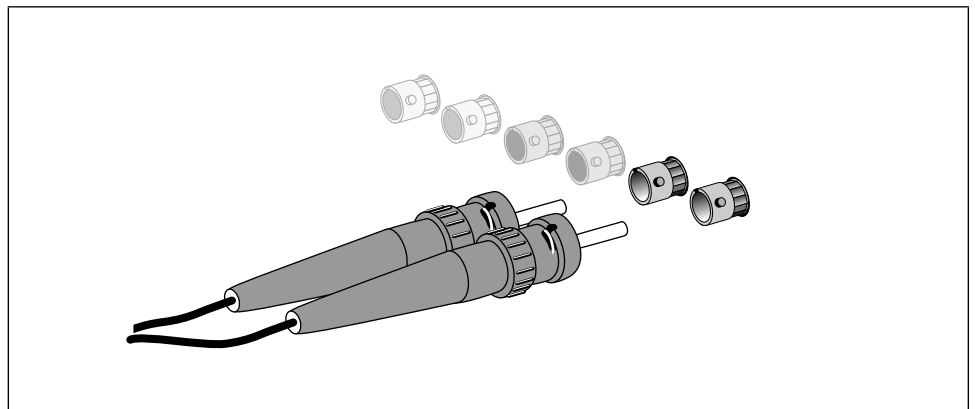

Figure 9: ST Connectors

Note that, since the ST connector is keyed, you should gently rotate the connector to ensure proper mating of the ST plug receptacle. Be careful not to force the connector mating or you might damage the hub's connector.

## AT-4016F/SC

---

The AT-4016F/SC has Subscriber Channel (SC) connectors which mate through a square push-pull interface.

SC connectors represent, for many individuals, an improvement over ST connectors in that they have a lock proof mechanism.

Figure 10 shows the front panel of an AT-4016F/SC.

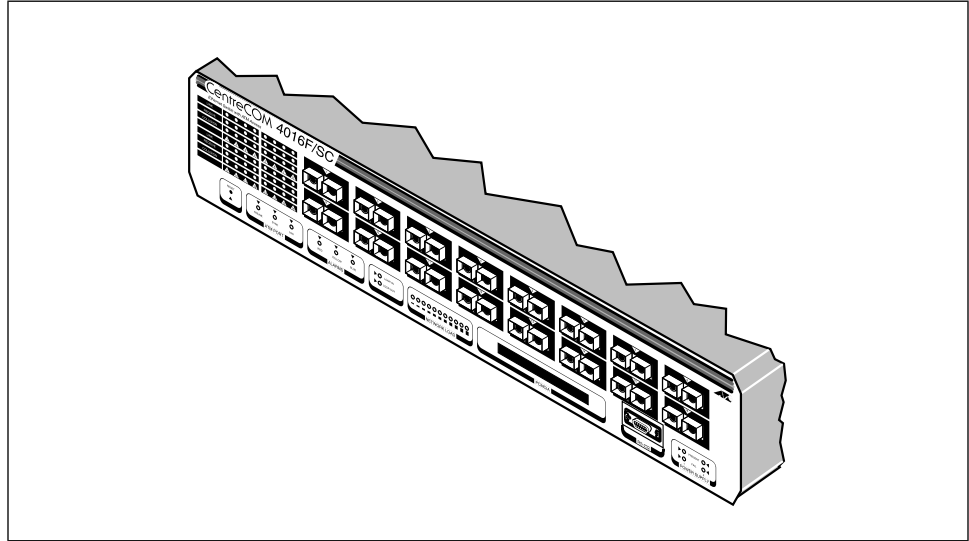

Figure 10: AT-4016F/SC  
Front Panel

Figure 11 shows an SC connector matrix with the locking device removed and suspended over the connectors.

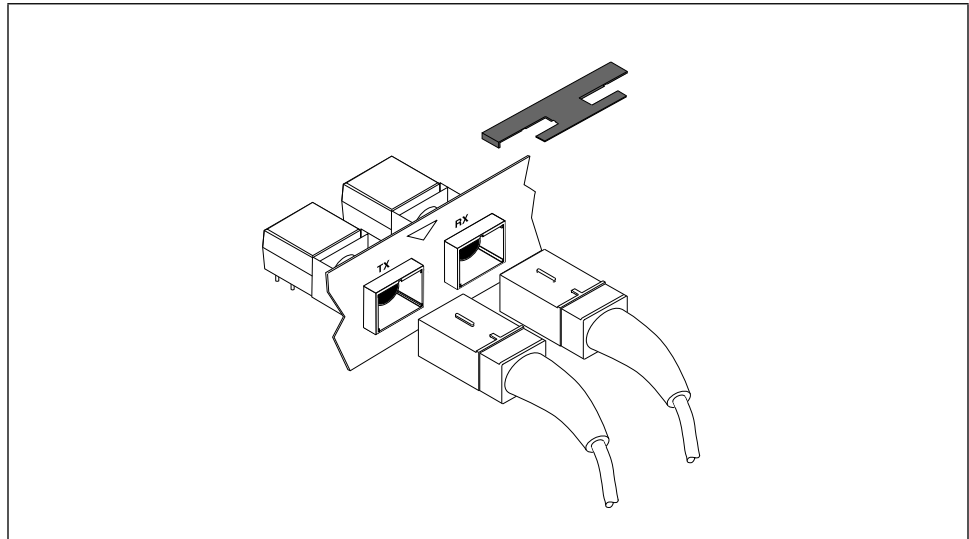

Figure 11: AT-4016F/SC  
Connector

Figure 12 shows an SC connector group with the locking device installed.

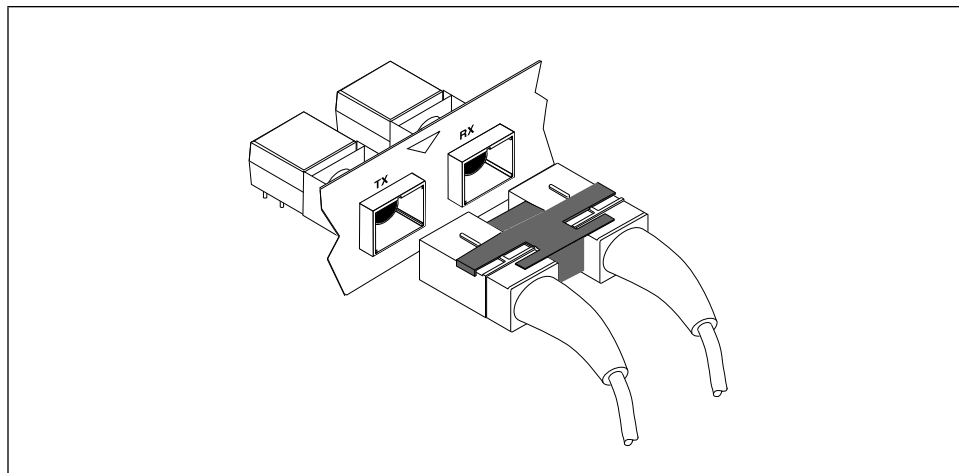

Figure 12: AT-4016F/SC  
Connector With  
Lock

## FOIRL, 10Base-FL Wiring Specifications

---

The IEEE FOIRL standard limits a fiber segment length to 1 km (1,000 meters or 3,280 feet). That is, the fiber optic cable that connects two repeaters is limited to 1 km (3,280 ft.).

While the more recent IEEE 802.3 10Base-FL standard is compatible with FOIRL, it can travel up to 2 km. (2,000 meters or 6,560 feet) using multimode duplex fiber optic cable in a point-to-point link which directly attaches two devices. Note, however, that the 2 km. distance only applies to topologies in which one 10Base-FL node connects to another 10Base-FL node.

That is, you can intermix 10Base-FL and FOIRL nodes, but if the cable connects a 10Base-FL node at one end and a FOIRL node at the other, the limitation would revert to the lesser distance of 1 km (3,280 ft.).

### Duplex Fiber Optic Cable

Both 62.5/125 micron and 50/125 micron duplex optical fiber cable is supported. Duplex refers to support for fiber optic cable pairs: a two-cable fiber optic connection with transmit mode dedicated to one cable and receive mode on the other.

Normally, duplex fiber optic cable is labeled TX or TD (transmit) and RX or RD (receive). You must connect the receiving port (RX or RD) on one device to the transmitting (TX or TD) port on a second device for proper connectivity.

To connect a network device to a fiber optic port on the AT-4016F:

1. Attach both connectors at one end of the cable to the TX and RX ports on the network device.
2. Connect one of the paired connectors at the other end of the cable to the RX port on the repeater.
3. Check for On Line indicator to illuminate. If it does, connect the other of the pair to TX. If On Line stays off, unplug the connector from RX and use the other of the pair.

## Configuration Rules

Depending on the medium you choose, there are certain wiring practices you must follow to ensure the reliability of communication throughout the network. The AT-4016F complies with IEEE standards for 802.3 Carrier-Sense Multiple-Access with Collision Detection (CSMA/CD) Ethernet and with ATM Forum UNI Specification 3.0; you should refer to these standards when implementing your network.

## Power Supply

The AT-4016F offers two redundant, removable, load-sharing power supplies.

Table 3 shows the model numbers for the different power arrangements:

Table 3: AT-4016F Model Configuration

AT-4016F Model	Power Cord	Power Supply
AT-4016F-12x	US Style Power Cord	Dual
AT-4016F-22x	International (no cord supplied)	Dual

The first digit in the model name suffix indicates whether a power cord is supplied. The second digit specifies a dual power-supply. The “x” in the model name suffix indicates the factory-installed ATM Media Module.

For example, an AT-4016F-122 is a switch with a U.S.A.-style power cord, dual power supply and, from Table 2, a 155 Mbps OC-3c/STM-1 multimode optical media module.

## Network Management

---

All units come equipped with firmware-installed network management agents. Additional information about AT-4016F network management can be found under the separate document *CentreCOM AT-4016TREthernet Switch with ATM Access — Operations Manual* which is shipped with each system.

There are three types of network management:

- Omega local network management (ASYNCR ASCII terminal port)
- Omega remote network management (Telnet session)
- SNMP

## Upgrading Software

The AT-4016F software is easy to upgrade through the PCMCIA memory port. When you insert a PCMCIA Flash Memory Card into this port, the new firmware is copied to the switch's onboard non-volatile flash memory at power-up. See the *CentreCOM AT-4016TREthernet Switch with ATM Access — Operations Manual* for information on management software capabilities and installation.

Further, an on-line Bulletin Board System (BBS) offers updated software files that can be downloaded through either the TCP/IP applications Trivial File Transfer Protocol (TFTP). This is discussed in the Preface of this document.

## Chapter 2

# Installation

---

### Site Preparation

---

---

Note

---

Before installing the *AT-4016F Ethernet Switch with ATM Access*, read the “Electrical Safety and Installation Requirements” on page i.

---

#### Location

The AT-4016F can be installed on a shelf, in a desktop chassis, or in a 19-inch rack which ATI has designated Model AT-31C1.

#### Ventilation

The installation site must have adequate ventilation to provide an operating environment consistent with an ambient temperature range of 0 to 40° C and a maximum 80% of non-condensing humidity. While the AT-4016F has internal fans to aid in cooling, for the fans to function correctly, you must provide 50 to 75 mm (2 to 3 in.) clearance around the ventilation openings. The ventilation louvers are located on the sides of the AT-4016F housing.

#### Power

Power connections for each system should be able to provide 100-120 watts at 100-120/200-240 VAC, 50/60 Hz, 2.0/1.0 Amp.

Since a reliable power source is a critical component of your network, ATI recommends your network components be installed on a dedicated power circuit. That is, dedicated power circuits or power conditioners tend to isolate network equipment from electrical-power noise, surges and interruptions.

## Installing the AT-4016F ATM Ethernet Switch

---

The following procedure details how to install an AT-4016F in a standalone configuration.

### **Installing the switch**

1. Plug one end of the power cord into the switch's power receptacle and the other end into a power outlet.
2. Check the front panel to see that the Power indicator illuminates for both power supplies. PS Present 1 indicates Power Supply #1 and PS Present 2 indicates Power Supply #2. Note that these redundant power supplies use a load sharing methodology — that is, while a single power supply provides sufficient power to operate the unit, the MTBF duration is greatly extended when a dual power supply configuration operates at half power.
3. Plug your Ethernet data cables into the AT-4016F and the network device (DTE). The Link Status indicator for each connected port will illuminate.
4. Please refer to the troubleshooting section of this manual if any on line LEDs are not functioning. Note that any communication between a node and the switch requires Omega management. LAN Emulation, in particular, requires Omega management.
5. The AT-4016F is now functional and ready to operate; see *CentreCOM AT-4016TR Ethernet Switch — Operations Manual* for details.
6. The following information only pertains to those who are going to attach the ATM portion of your switch at this time.

Attach one end of your fiber optic cable to the ATM Physical Interface Module at the back of the AT-4016F and the other end to the ATM port. The ATM Online LED should illuminate. Additionally, if the Loss of Signal (LOS) LED illuminates, the fiber pairs are either crossed (incorrectly installed) or there are other cable problems.



## Installing the Redundant Power Supplies

The AT-4016F has a redundant, dual power-supply. See Table 3 in Chapter 1 for the list of AT-4016F models. Power supply modules are keyed so that they will only fit in the appropriate switch housing.

The following procedure details how to replace an AT-4016F power supply.

### ▶ Replacing a power supply

---

#### Caution

---

When inserting or removing power supplies using the hot swapping method, the power cord should remain plugged in.

---

1. An illuminated PS Fail 1 or PS Fail 2 LED indicates a failure in a power supply. (PS Fail LEDs are located at the lower right corner of the AT-4016F front panel; see Chapter 3 for details.)
2. Leaving the AC power cord attached, loosen the two screws that secure the power supply you want to replace (see Figure 13).

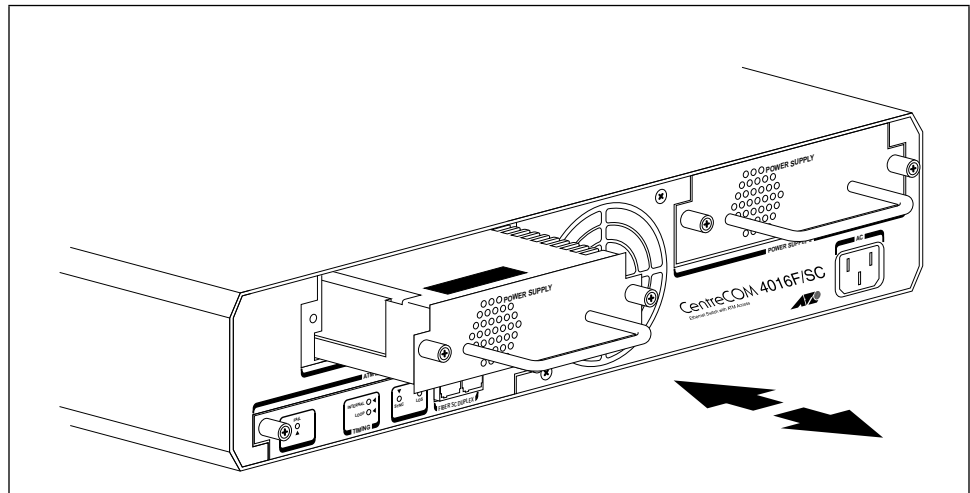

Figure 13: AT-4016F Power Supply Replacement

---

#### Attention

---

Loose metal parts can cause damage to exposed circuit boards and components. Handle parts and any required tools with care during installation.

---

3. Carefully slide the power supply module out from the switch housing.
4. Insert the replacement power supply until the faceplate of the module is flush with the switch housing.
5. Tighten the two screws to secure the power module.
6. Ensure that the power LEDs are illuminated.

## Media Module Installation

ATM Physical Media Modules are available in several versions for differing network requirements.

### ▶ Installing ATM Media Modules

ATM Media Modules plug into the Media Channel connector located on the AT-4016F back panel.

#### Attention

You must disconnect the AT-4016F from its power source to install or swap ATM Media Modules.

1. Disconnect the AC power cord from the AT-4016F.
2. Unplug any data cables connected to the current ATM Media Module. (If no ATM Media Module is currently installed, skip this step.)
3. Unscrew the screws at the outer edges of the current module's faceplate (or blank faceplate, if no module is currently installed).
4. If you are replacing a module, unplug the current module from the AT-4016F's 96-pin ATM Media card connector and slide it out from the housing (see Figure 14).

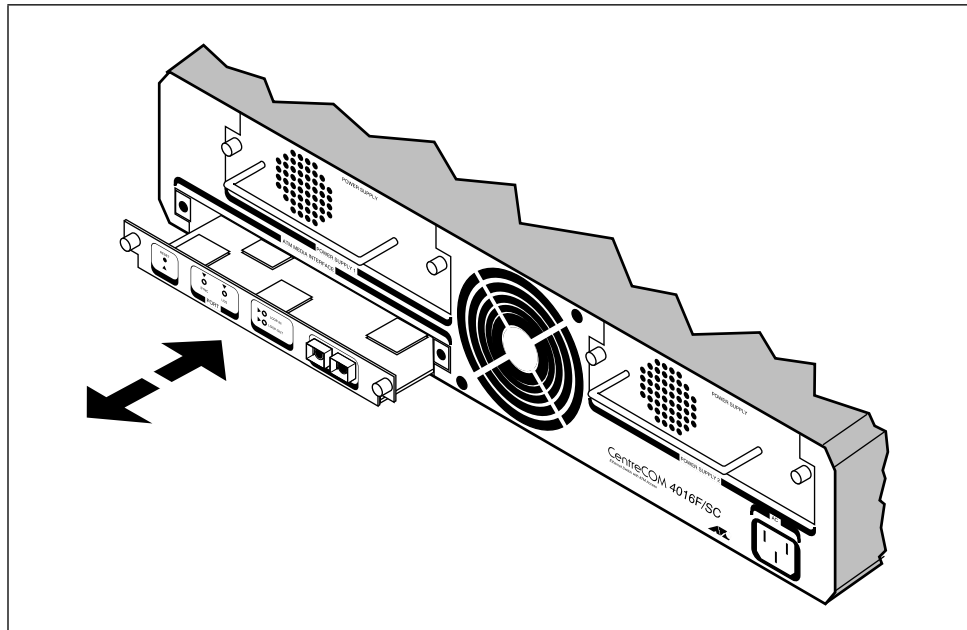

Figure 14: Replacing an ATM Media Module

5. Carefully insert the new module until it plugs into the ATM Media card connector and its faceplate is flush with the AT-4016F housing.
6. Tighten the two screws to secure the new module.
7. Reconnect the AC power cord to power on the system.

## Chapter 3

# Connectivity

---

This chapter describes network hardware functions. The first two sections cover the layout of the front and back panels. The rest of the chapter covers the functionality of the different components: connectors, indicators and switches.

## Front Panel

---

An AT-4016F/SC front panel is shown in Figure 15.

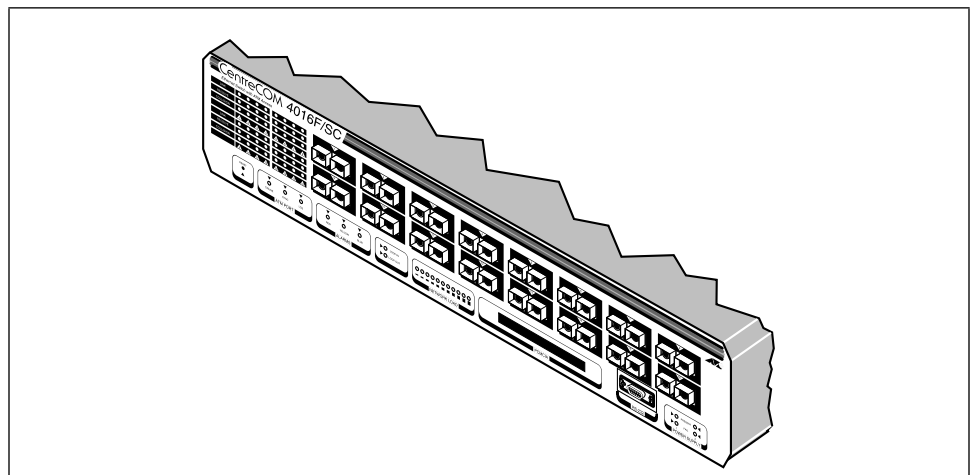

Figure 15: AT-4016F/SC  
Front Panel

The front panel includes the following components:

- ❑ 16 Fiber Optic — either SC or ST — station ports
- ❑ RS232 Terminal Port
- ❑ PCMCIA Flash Memory slot
- ❑ Recessed Reset Switch
- ❑ Diagnostic LEDs:
  - Network Loading indicators
  - ATM Port indicators
  - Individual Fiber Optic Port Interface indicators
  - ATM Media Alarms and Power Supply indicators

## Back Panel

---

An AT-4016TR/SC back panel is shown in Figure 16.

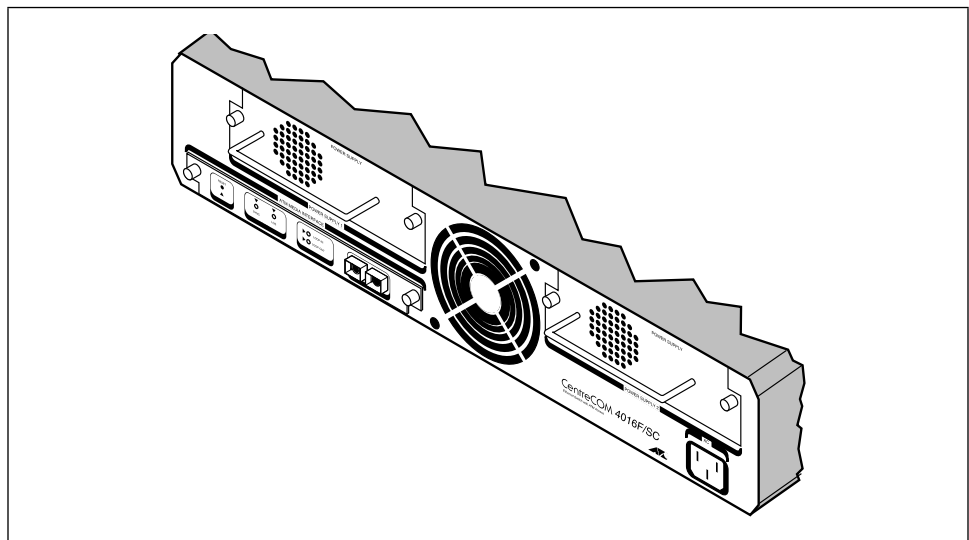

Figure 16: AT-4016F Back Panel

The back panel includes the following components:

- ❑ Power supply modules)
- ❑ ATM Media Interface slot
  - ATM Interface indicators
- ❑ AC power receptacle

## AT-4016F Ports

---

### Station Ports

There are 16 Fiber Optic station ports which can be used to connect to workstations, servers or hubs.

### RS232 Terminal Port

The AT-4016F includes an RS232 Terminal Port on the front panel. The principal use for this port is the connection of a local network management terminal to access AT's Omega agent.

### PCMCIA Interface

The PCMCIA Interface port, located on the front panel, is a read-only interface that uses a standard 16-bit 2MB Flash EPROM PCMCIA card to either restore software or to download updated software.

If a PCMCIA firmware card is installed before a reset or power-up sequence, the AT-4016F boots from the PCMCIA card. Otherwise, it boots from internal Flash RAM. For further details, see *CentreCOM AT-4016TR Operations Manual*.

### ATM Media Interface

Located on the back panel, the ATM Media Interface can accommodate multimode fiber, single mode fiber, or Level 5 UTP wire. An internal 96-pin DIN receptacle mates to the switch's ATM Media Interface card.

Table 1 on page 2 lists the different types of media modules.

Figure 17 shows the factory-installed removable ATM Media Interface that has been configured for a multimode fiber optic network. This Interface can be used to connect to another AT-4016F, an ATM Switch, or to an ATM adapter.

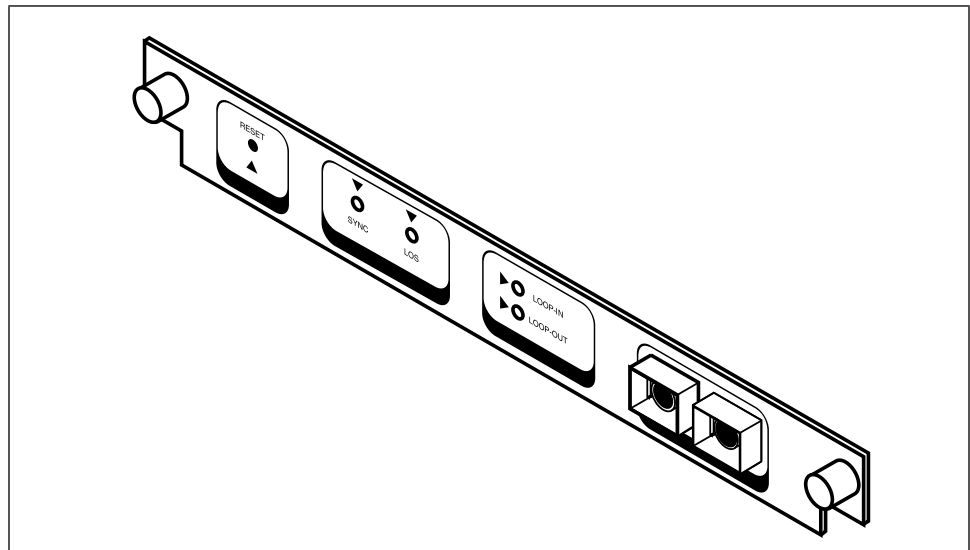

Figure 17: ATM Media Interface

## LED Displays

---

The AT-4016F has four types of LEDs:

- ❑ System Status indicators show the overall condition of the switch
- ❑ Power Supply Indicators
- ❑ Port indicators shows information about each Fiber Optic port connection.
- ❑ ATM Interface indicators show status and alarm information about the ATM Physical Interface

### System Status LEDs

**Network Load (Green)**—Indicates approximately how much of the switch's capacity is being used, depending on how many of the 10 LEDs in the gradient light up. Figure 18 shows the Network Load LEDs.

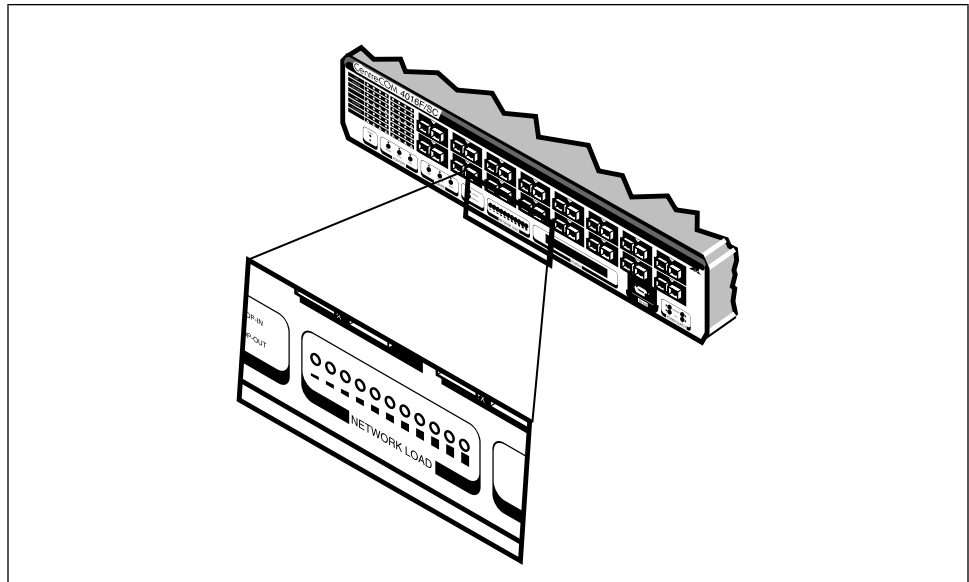

Figure 18: Network Load LEDs

Note that Omega management software will always provide more information about your network than just an LED.

## Power Supply LEDs

Figure 19 shows the Power Supply LEDs.

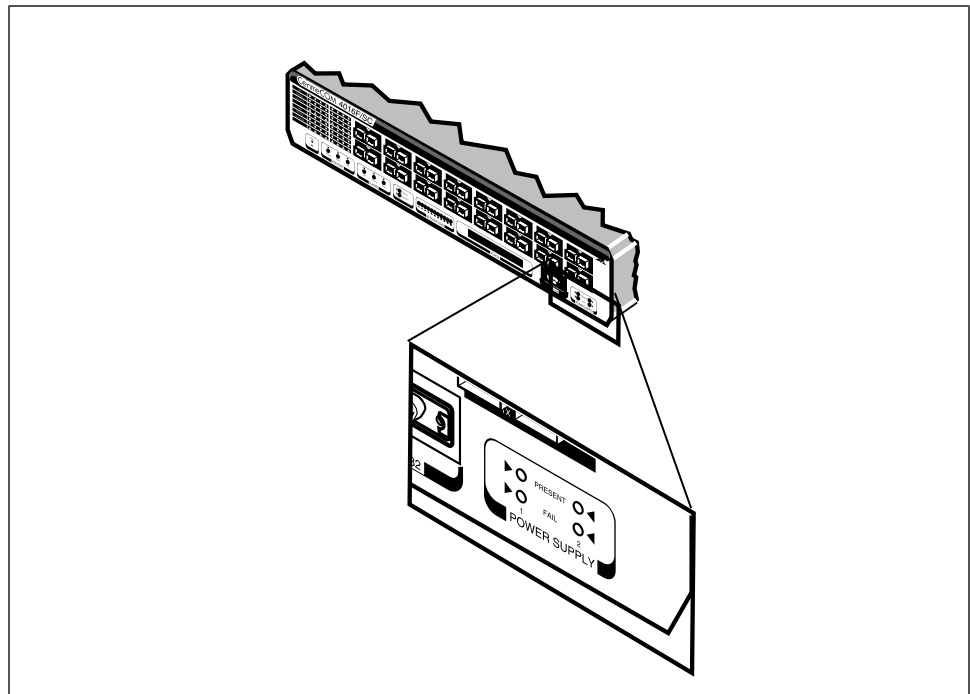

Figure 19: Power Supply LEDs

**PS Present 1 (Green)**—Indicates Power Supply #1 is installed.

**PS Present 2 (Green)**—Indicates Power Supply #2 is installed.

**PS Fail 1 (Amber)**—Indicates Power Supply #1 has failed. This means that there is either an inadequate, or nonexistent, amount of AC voltage.

**PS Fail 2 (Amber)**—Indicates Power Supply #2 has failed. This means that there is either an inadequate, or nonexistent, amount of AC voltage.

## Fiber Optic Port LEDs

The port indicators on the AT-4016F front panel provide visual diagnostic and activity information for network analysis. Each Fiber Optic port supports the following indicator functions with three front panel LEDs per port, arranged in a central bank as shown in Figure 20.

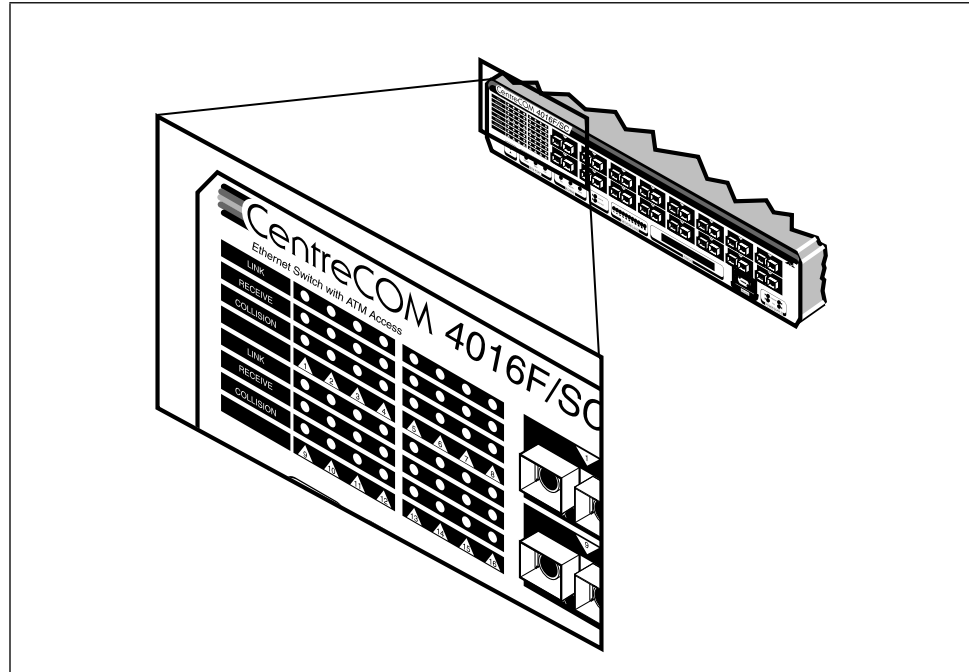

Figure 20: Port Indicators

**LINK (Solid Green)**—This indicates that the particular port has a valid link and is not partitioned.

**LINK (Amber)**—This indicates that the particular port does not have a valid link or it is partitioned.

**RECEIVE (Flashing Green)**—This indicates that the port is receiving Ethernet packets.

**COLLISION (Flashing Amber)**—This LED will flicker to indicate packet collisions. Although occasional collisions are normal in Ethernet networks, excessive collisions are an indication of possible segment problems. A constantly illuminated Collision LED may indicate that there is a port problem, cabling problem, or excessive traffic problem.

If you believe there are excessive packet collisions, then you are advised to consider Omega management for additional information such as the amount of transmitted packets instead of collisions.



## ATM Interface LEDs

The AT-4016F supports an additional set of indicators that convey diagnostic and status information about the ATM Physical Interface. The location of these indicators is shown in Figure 21.

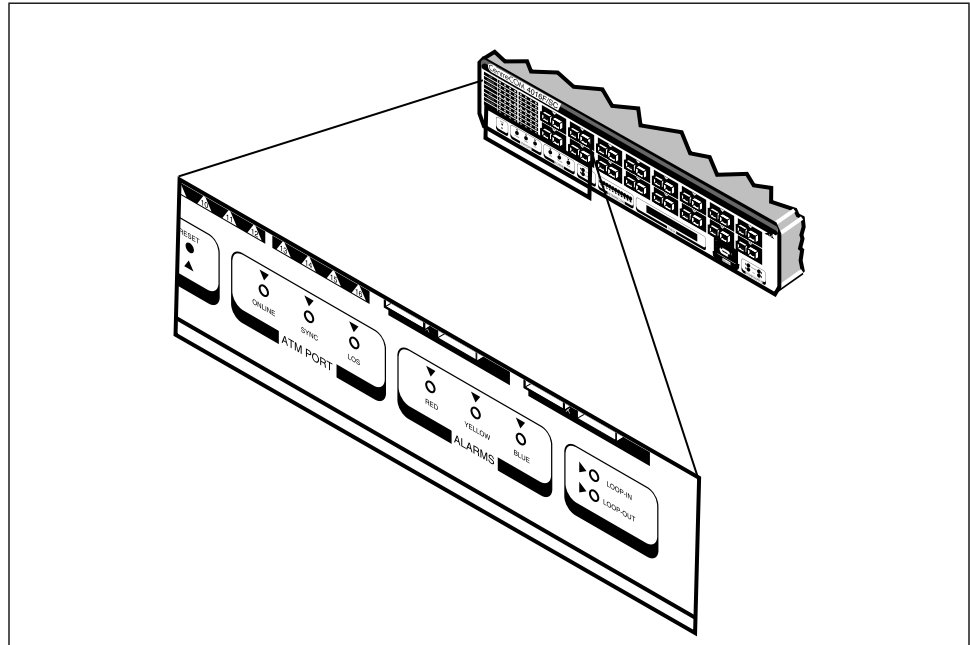

Figure 21: ATM Interface LEDs

### ATM Port LEDs

**ONLINE** (Solid Green)—Indicates that the ATM Physical Interface is active (enabled).

**SYNC** (Synchronization) (Solid Green)—Indicates that the ATM Physical Interface has synchronization.

**LOS** (Loss Of Signal) (Amber)—Indicates that the ATM Physical Interface is experiencing a Loss Of Signal or the cables are not installed.

### Alarms LEDs

**RED** (Amber)—A RED Alarm on the ATM Physical Interface indicates either the system is rebooting or there is a signal failure condition at the source.

**YELLOW** (Amber)—A YELLOW Alarm on the ATM Physical Interface indicates to the AT-4016F (source device) has a signal failure condition at the destination (sink device). This is usually associated with DS3/E3 interfaces.

**BLUE** (Amber)—A BLUE Alarm Indication Signal or AIS Alarm indicates that a different signal has replaced the normal traffic signal when a maintenance alarm indication has been activated. An AIS is also referred to as a “Blue Alarm,” “Alarm Inhibit Signal” or “Keep Alive Signal.”

### LOOP LEDs

**LOOP-IN** (Green)—Indicates that any TX traffic on the ATM Physical Interface will be looped back to AT-4016F RX inputs.

**LOOP-OUT** (Green)—This indicates that any RX traffic on the ATM Physical Interface will be looped back to the ATM Interface TX connection.

## ATM Media Module LEDs

A further set of indicators appears on the ATM Media Module. Located on the back panel of the AT-4016F, these LEDs convey diagnostic and status information specific to the type of media connection that has been installed. The location of these indicators is shown in Figure 22. A brief discussion of their functions follows.

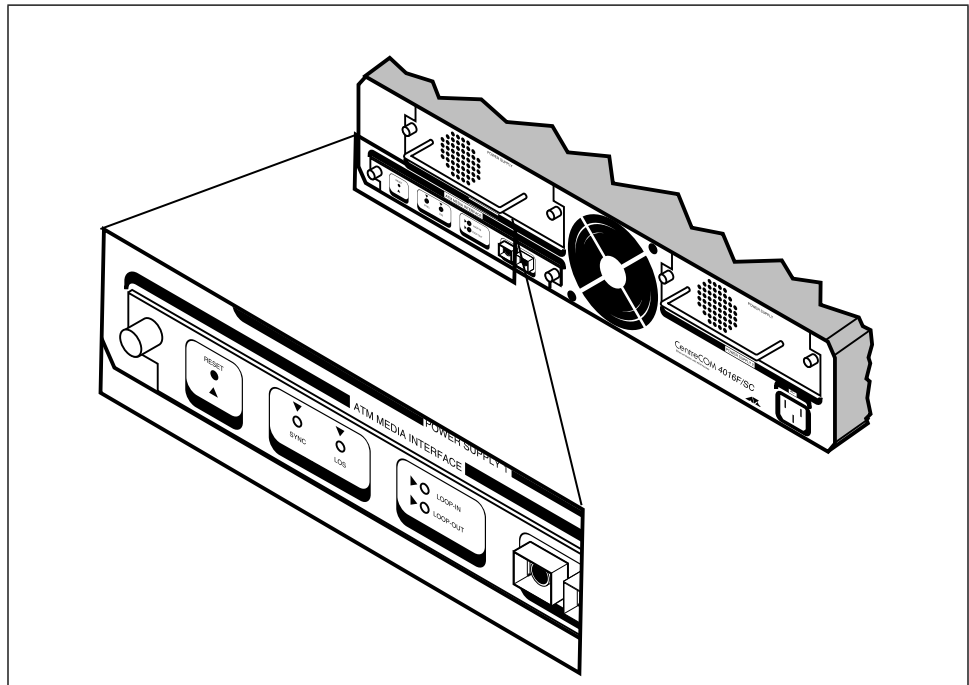

Figure 22: ATM Media Module LEDs

**FAIL** (Amber)—This LED indicates that the ATM Media Channel has failed self-test or is disabled.

**TIMING**—(Green) This indicates the timing source of the ATM Media Transmit (TX) signal. This source can be either INTERNAL or LOOP.

- **INTERNAL**—The TX signal timing is derived from an internal time-base. The AT-4016F acts as the timing master.
- **LOOP**—The TX signal timing is derived from the Receive (RX) signal timing. The AT-4016F acts as the timing slave.

**SYNC** (Green)—This LED indicates that the ATM Media Channel has clock synchronization (bit-level).

**LOS** (Loss Of Signal) (Amber)—This indicates that the ATM Media Channel is experiencing a Loss Of Signal on the Receive (RX) line. The problem may be caused by cables that are not installed correctly.

## Reset Switch

---

Located at the far left of the front panel (as shown in Figure 23), this switch is recessed to avoid inadvertent activation. To press the switch, insert the tip of a pen or similar object into the access hole.

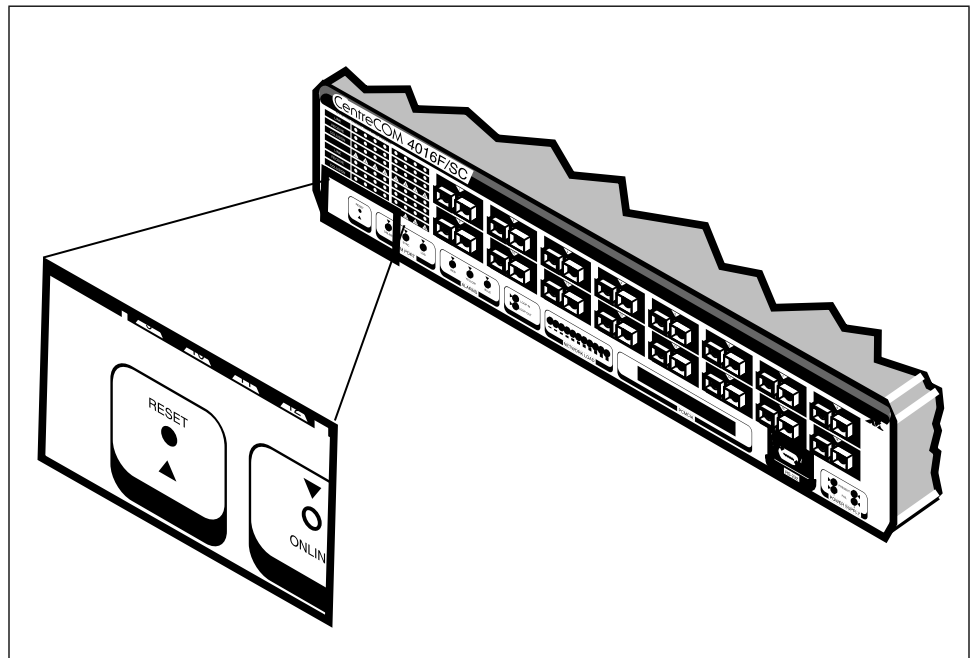

Figure 23: Reset Switch

The Reset switch initiates the same diagnostic self-testing cycle which takes place when you initially apply power to the system.



# Chapter 4

## Troubleshooting

---

### Troubleshooting the Installation

---

This section provides a checklist for resolving problems associated with your AT-4016F and cabling.

The first rule of troubleshooting is to isolate the problem. As you experiment, only vary one factor at a time. Substitute known good equipment and see if the problem persists or is eliminated.

▶ **As a preliminary check, perform the following steps**

1. **Do not overlook the obvious**—check diagnostic LEDs and make sure the cables and connectors are securely attached.
2. **If there is no power indication**, check that the power plug is properly seated at the AT-4016F switch and at the AC receptacle.

### LED Indicators

---

The following are suggested courses of action in response to specified LED indicator conditions:

#### Power Supply LEDs

- ❑ **If PS Fail 1 or PS Fail 2 lights up**, you may have a failure in one of the removable power supplies. Replace the affected power supply and check the indicator again.

#### ATM Media Module LEDs

- ❑ **If the ATM FAIL indicator lights. Replace the module.**
- ❑ If the ATM TIMING indicator is not lighted. Reconfigure the ATM channel through the Omega management agent and at the corresponding ATM port at the other end of the segment. Make sure the channel definitions are compatible.
- ❑ **If the ATM LOS indicator lights.** Check the ATM Media Channel connections at both ends of the cable. Since you are only using optic media, try exchanging the Transmit (TX) and Receive (RX) connectors and check whether the LOS light stays lighted.
- ❑ **If the ATM SYNC indicator is not lighted.** There may be a cable problem or a configuration problem.



# Appendix A

## Glossary

---

**10BASE-T**—IEEE 802.3 UTP Ethernet. Low-cost Level 3 or better UTP wiring affords 100 meters (328 ft.) of point-to-point link segments. UTP uses RJ-45 connectors and sometimes 50-pin AMP connectors to a patch panel and runs at 10 MHz.

**ADDRESS RESOLUTION PROTOCOL (ARP)**—The procedures and messages in any communications protocol which resolve local addresses to those of the network. In TCP/IP, the protocols for translating between IP addresses and physical addresses.

**ASYNCHRONOUS TRANSFER MODE (ATM)**—A technology for LAN data transport that packages the data in short fixed length cells for high-speed transport.

**ATM FORUM**—An international voluntary organization composed of ATM vendors, manufacturers, service providers, research organizations and users. Purpose is to “accelerate the use of ATM products and services through the rapid convergence of interoperability specifications, promotion of industry cooperation and other activities.”

**ATTACHMENT UNIT INTERFACE (AUI)**—Connection between a MAU (transceiver) and a DTE (typically a workstation). Includes a 15-pin D-sub connector and sometimes a 15-conductor twisted pair cable. Maximum length is 50 meters (164 ft.).

**BASEBAND COAXIAL SYSTEM**—A system whereby information is directly encoded and impressed on the coaxial transmission medium. At any point on the medium, only one information signal at a time can be present without disruption.

**BAYONET NUT COUPLE (BNC) CONNECTOR**—A 10Base2 thin coax connector with push-on BNC locking lug that quickly locks into place with a half twist.

**BIT RATE (BR)**—The rate of data throughput on the medium in bits per second. Ethernet specifies 10 million bits per second.

**BIT TIME**—The duration of one bit symbol (1/BR). Ethernet specifies a bit time of 100 ns.

**BROADCAST AND UNKNOWN SERVER (BUS)**—BUS defines that set of functions implemented in an ATM network that provide LAN-to-LAN transmission support while a LAN connection is being established. It also supports LAN broadcast services.

**CARRIER SENSE**—In a LAN, an ongoing activity of a data station to detect whether another station is transmitting.

**CARRIER SENSE MULTIPLE ACCESS with COLLISION DETECT**

**(CSMA/CD)**—This is the access method employed by IEEE 802.3 LAN transceivers, by which multiple stations compete for use of the transmission medium (coax cable) for data packet transmission. It provides for a level of error detection should that transmission be corrupted or impeded by contention for the transmission medium.

**COAXIAL CABLE**—A two-conductor (center conductor, shield system), concentric, constant impedance transmission line used as the trunk medium in the baseband system.

**COAXIAL CABLE SEGMENT**—A length of coaxial cable sections and coaxial connectors, terminated at each end in its characteristic impedance.

**COLLISION**—An unwanted condition that results from concurrent transmissions on the physical medium.

**COLLISION PRESENCE**—Provides the ability to detect simultaneous occurrence of Manchester-encoded data on the DI and DO and to report such an occurrence as a collision.

**COMPATIBILITY INTERFACE**—The MDI coaxial cable interface and the AUI branch cable interface, the two points at which hardware compatibility is defined to allow connection of independently designed and manufactured components to the baseband transmission system.

**CROSSOVER**—Wiring used when connecting a 10Base-T MAU to another 10Base-T MAU or a 10Base-T hub to another 10Base-T hub. For example, one 10Base-T MAU has the TD pair on the same pins as another 10Base-T MAU. If pins were wired straight, there would be two transmitters on one pair and no receiver. As a solution, the crossover cable crosses the TD pair with the RD pair, to connect the TD pins on one end to the RD pins at the other end.

**CYCLIC REDUNDANCY CODE (CRC)**—An algorithm used to check for and correct bit errors in data transmission.

**D-SUB CONNECTOR**—The AUI cable uses 15-pin D-sub connectors. “D” refers to the shape of the connector shell. Also called miniature D, DB15, or DIX connectors.

**DATA COMMUNICATION EQUIPMENT (DCE)**—In RS232 specification a module, such as a modem, for connecting a DTE to other equipment. A repeater connected to a terminal or workstation for OMEGA management use is wired as a DCE.

**DATA TERMINAL EQUIPMENT (DTE)**—In RS232 specification a module typically at the end of a segment. The DTE could be an Ethernet workstation, repeater or bridge.

**EMULATED LOCAL AREA NETWORK (ELAN)**—See LAN Emulation.

**FOIRL** — A fiber optic standard that allows up to 1,000 meters (3,280 ft.) of multimode duplex fiber optic cable in a point-to-point link.

**HARMONICA ADAPTER**—This adapter provides a simple way to convert the 50-pin Telco connection to RJ-45 connections.

**HEARTBEAT**—See SQE

**HOT SWAPPING**— The process of replacing a module without interrupting the network. This process occurs by sliding an active module into a fully powered up unit, replacing a failed module.

**HOUSE WIRING**—House wiring is the existing wiring inside a building. This wiring generally originates from one or more wiring closets, such as a telephone room. Some older buildings may have wiring unsuitable for 10 megabit data rates. In these circumstances, it is recommended that the wiring be tested with a 10Base-T signal/wire tester.



**HUB/REPEATER**—A hub is a central signal distributor. It is used in a wiring topology consisting of several point-to-point segments originating from a central point. The term hub is often used interchangeably with the term repeater. Multiport 10Base-T, 10Base2 and fiber optic (10Base-FL, FOIRL) repeaters are considered hubs. See Repeater.

**HUB-to-HUB WIRING**—See MAU-to-MAU Wiring

**HUB-to-MAU WIRING**—UTP cables for 10Base-T hub-to-MAU or NIC cards are wired straight-through. An RJ-45 receptacle at the hub would wire pin-to-pin to the RJ-45 receptacle at the MAU.

**IMPEDANCE**—An electrical characteristic of a circuit dealing with the combination of the AC and DC resistance and the appearance of that resistance to attached circuits.

**INTERIM LAYER MANAGEMENT INTERFACE (ILMI)**—Protocol defined by the ATM Forum UNI standards for managing the UNI.

**JABBER LOCK-UP**—The MAU's ability to automatically inhibit the transmit data from reaching the medium if the transmit data time exceeds a specified duration. This duration is in the range of 20 ms to 150 ms. Jabber lock-up protects the medium from being overrun with data packets from a possibly defective device.

**JAM**—This is a term used to describe the collision reinforcement signal output by the repeater to all ports. The jam signal consists of 96 bits of alternating 1s and 0s. The purpose is to extend a collision sufficiently so that all devices cease transmitting.

**JITTER**—The fluctuation of the data packet in respect to a standard clock cycle. Jitter is undesirable and must be minimized.

**LAN**—See Local Area Network

**LAN EMULATION**—Methodology for mimicking the appearance of a LAN by rendering the ATM switching fabric invisible to the user; enables user interface software to treat a virtual LAN as if it were a physical LAN.

**LAN EMULATION CLIENT (LEC)**—ATM Forum-defined specifications in support of LAN-to-LAN connectivity, called LAN Emulation. LEC defines that set of functions implemented in a LAN DTE to interface with an ATM network in support of LAN Emulation.

**LAN EMULATION SERVER (LES)**—LES defines that set of functions implemented in an ATM network in support of LAN-to-LAN connection establishment.

**LAN EMULATION CONFIGURATION SERVER (LECS)**—LECS defines that set of functions implemented in an ATM network that provide LAN DTEs with information regarding the location of the other LAN Emulation services.

**LINK SEGMENT**—The link segment of coaxial cable is a segment that has no MAU devices, but links together two LAN devices such as repeaters.

**LINK TEST**—In 10Base-T Ethernet there is a link test function that validates the UTP link. This consists of a pulse transmitted from point A on one pair that is validated at point B. Point B also transmits a pulse on the second pair to be validated by point A. These pulses occur during media idle states (in between packets).

**LOCAL AREA NETWORK (LAN)**—A type of limited-area broadcast network in which devices attached to a common transmission medium.

**MEDIA ACCESS CONTROL (MAC)**—IEEE specifications for the lower half of the data link layer (layer 2) that defines topology-dependent access control protocols for IEEE LAN specifications.

**MANAGEMENT AGENT**—Software that is used to view system activity and set system variables.

**MAU**—See Medium Attachment Unit

**MAU-to-MAU, HUB-to-HUB WIRING**—10Base-T MAU-to-MAU or hub-to-hub wiring generally requires a crossover cable located somewhere along the UTP cable run. This may commonly occur at the punch-down block or between the RJ-45 wall receptacle and the workstation.

**MAU/TRANSCEIVER**—An Ethernet transceiver is a MAU. A 10Base-T MAU interfaces the UTP media to an AUI port on a workstation, repeater, bridge or other Ethernet device.

**MDI/MDI-X**—See Medium Dependent Interface

**MEDIUM ATTACHMENT UNIT (MAU)**—In a LAN, a device used in a data station to couple the DTE to the transmission medium.

**MEDIUM DEPENDENT INTERFACE (MDI)**—The mechanical and electrical interface between the trunk cable medium and the MAU. MDI-X is another version of the interface that enables like devices to connect using different pin-outs, thereby avoiding conflicts that occur when receiving and transmitting packets use the same pin-out.

**MANAGEMENT INFORMATION BASE (MIB)**—A data base of network configuration and performance information. The formal definition of a MIB includes the names of the objects it contains and the type of information retained. Management protocols such as SNMP and CMIP contain procedures for acquiring and exchanging MIB information.

**MULTIMODE FIBER**—Type of fiber optic cable used for transmitting data over relatively short distances (maximum 2 km). The fiber contains two materials with different refractive indices and uses reflection to propagate a relatively low-intensity signal (Class 3 or equivalent).

**NETWORK SERVICES ACCESS POINT (NSAP)**—OSI generic standard for a network address consisting of 20 octets. ATM has specified E.164 for public network addressing and the NSAP address structure for private network addresses.

**PATCH PANEL**—A 10Base-T patch panel may be used between a punch-down block and UTP workstation. The patch panel generally has a female RJ-45 connector on the front for each workstation and a Telco (RJ21) connector on the back, which is wired to a punch-down block. This provides a convenient way for the installer or network manager to connect the hub 10Base-T ports into the desired building locations.

**PERMANENT VIRTUAL CIRCUIT (PVC)**—A virtual circuit (x.25), virtual connection (Frame Relay) or virtual channel connection (ATM) that has been established by manual or semi-automated methods in advance of its need. Analogous to a leased/dedicated/provisioned real circuit.

**PHYSICAL MEDIUM ATTACHMENT (PMA)**—The portion of the MAU that contains the functional circuitry.

**PHYSICAL SIGNALING (PLS)**—That portion of the physical layer contained within the DTE that provides the logical and functional coupling between MAU and data link layers.

**POLARITY CORRECTION**—Many 10Base-T UTP ports have a polarity correction function. If the UTP wiring has RD- and RD+ inadvertently crossed, the polarity correction function will sample the signal and electrically swap the wires. If the TD- and TD+ wires are crossed, the correction would occur at the MAU on the other end of the UTP link. This occurs within a single pair and should not be confused with the crossover cable.

**PROPAGATION DELAY**—The time it takes a signal to travel from the input of a system component to the output. Usually measured in nanoseconds. IEEE 802.3 has specific propagation delay maxima for computing propagation budgets when designing a LAN. Cable length plays a major role in propagation delay; for example, a 50-meter (164-foot) AUI cable has a maximum allowable propagation delay of 257 ns. The propagation delay of cable depends on the length and velocity factor of the cable type. There are also propagation delays associated with electronics attached to the system.

**PUNCH-DOWN BLOCK**—The punch-down block is the wiring panel where the house wiring from the building's offices terminates. This is where many 10Base-T hubs would be located. Wiring installers use a special punch-down tool to insert the UTP wire for data and voice applications.

**REPEATER**—A device used to extend the length, topology, or interconnectivity of the physical medium beyond that imposed by a single segment, up to the maximum allowable end-to-end trunk transmission line length. Repeaters perform the basic actions of restoring signal amplitude, waveform and timing applied to normal data and collision signals.

**RJ-45**—This connector is a 10Base-T standard for connecting UTP cabling. It is inexpensive and easy to install onto UTP cable.

**SDH**—See Synchronous Optical Network

**SIGNAL QUALITY ERROR (SQE) TEST**—Signal indicates SQE function is active. The SQE message is sent by the MAU to the DTE in the presence of a collision.

**SIMPLE NETWORK MANAGEMENT PROTOCOL (SNMP)**—SNMP is a TCP/IP protocol that generally uses the User Datagram Protocol (UDP) to exchange messages between a management information base and a management client residing on a network. Since SNMP does not rely on the underlying communication protocols, it can be made available over other protocols, such as XNS or DECnet.

**SINGLE MODE FIBER**—Type of fiber optic cable that uses wave propagation within a homogenous medium to transmit signal over long-range distances (5 to 10 km). Requires high-intensity laser light source (Class 1 emission).

**SONET**—See Synchronous Optical Network.

**SQE TEST**—Commonly referred to as Heartbeat, is a special 802.3 signal sent by the MAU to the DTE to test the collision detection function. Some DTE want SQE and others do not. Repeaters do not want the SQE Test.

**STANDALONE**—Repeater operating as a hub on its own; i.e., not a module among other modules in a department concentrator chassis.

**STRAIGHT-THROUGH**—A type of wiring connection where the pins of one connector connect to the same pins of another connector. For example, pin 1 of one connector connects to pin 1 of another connector.

**STRAIGHT TIP (ST) CONNECTOR**—A type of port connection where the pins connect through a bayonet-style interface.

**SUBSCRIBER CHANNEL (SC) CONNECTOR**—A type of port connection where the pins connect through a push-pull mating interface.

**SUB MINIATURE ASSEMBLY (SMA) CONNECTOR**—A type of port connection where the pins connect through a threaded attachment interface. Also referred to as an SM Connector.

**SWITCH, ETHERNET**—A type of Ethernet hub that filters traffic based on low-level address. As over against a repeater, a switch does not necessarily broadcast, retime or retransmit packets, depending on its configuration. A switch cuts down on traffic by placing packets only on the receiver's segment when known.

**SWITCHED VIRTUAL CIRCUIT (SVC)**—A virtual circuit (X.25), virtual connection (Frame Relay) or virtual channel connection (ATM) that has been established dynamically in response to a signaling request message.

**SWITCHED LAN**—Emerging technology that replaces the shared bus backplane of Ethernet hubs and the shared ring backplane of token Ring hubs with a switching backplane. Connectivity is provided by switching sender traffic directly to the port of the addressed destination device. Provides potentially higher throughput, scalable capacity, and simpler configuration support. Does not require any changes to access wiring or adapter cards.

**SYNCHRONOUS OPTICAL NETWORK (SONET)**—Also called the Synchronous Digital Hierarchy (SDH), a set of physical layer definitions for data transmission across fiber-based high-speed links.

**TCP/IP PROTOCOLS**—A set of protocols for intercomputer communication, including network level (Internet Protocol), transport level (Transmission Control Protocol or TCP) and application level protocols (for example, Telnet terminal emulation). TCP/IP has been used for many years in two country-wide networks, the ARPANET and MILNET. Recently, TCP/IP has become very popular with users of a variety of multi-user computer systems and engineering workstations. Most UNIX computers use TCP/IP over Ethernet as the main intercomputer networking technology. TCP/IP is also popular among PC users, particularly as a means of communication with large multi-user computers.

**TELCO CONNECTOR**— A 50-pin receptacle that plugs into the front of the hub, enabling cables from external devices to connect to the hub.

**TRUNK CABLE**—Coaxial cable used for distribution of signals over long distances throughout a cable system.

**UNSHIELDED TWISTED PAIR (UTP)**—A cable used in 10Base-T wiring that consists of at least two twisted pairs of 22 to 26 AWG wire. The pairs should have at least 3 twists per foot and have an impedance of 100 W. Level 3, Level 4 and Level 5 UTP cables fit these criteria.

**USER-TO-NETWORK INTERFACE (UNI)**—The interface between an end device and a public or private ATM switch.

**VIRTUAL CIRCUIT (VC)**—A connection between end users that has defined end points and route but does not have bandwidth dedicated to it. Bandwidth is allocated on demand by the network as users have traffic to transmit.

**VIRTUAL CHANNEL CONNECTION (VCC)**—Virtual channels in two or more sequential physical circuits can be concatenated to create an end-to-end connection called a VCC. A VCC is a specific instance of a SVC or PVC. A VCC may traverse one end-to-end VPC or several sequential VPCs.

**VIRTUAL CIRCUIT IDENTIFIER (VCI)**—Field in an ATM cell that maps the cell's route through the ATM network.

**VIRTUAL LAN (VLAN)**—A user-configured logical workgroup or collection of Ethernet addresses, as opposed to a physical LAN defined entirely by wiring.

**VIRTUAL PATH IDENTIFIER (VPI)**—Field in an ATM cell that maps the cell's route through the ATM network.

*Appendix B*

# *Technical Support Fax Order*

---

Name \_\_\_\_\_  
Company \_\_\_\_\_  
Address \_\_\_\_\_  
City \_\_\_\_\_ State/Province \_\_\_\_\_ Zip/PostalCode \_\_\_\_\_  
Country \_\_\_\_\_ Phone \_\_\_\_\_ Fax \_\_\_\_\_

## **Incident Summary**

---

Model number of Allied Telesyn product I am using \_\_\_\_\_

Firmware release number of Allied Telesyn product \_\_\_\_\_

Other network software products I am using (e.g., network managers)

\_\_\_\_\_

Brief summary of problem \_\_\_\_\_

\_\_\_\_\_

Conditions (List the steps that led up to the problem.) \_\_\_\_\_

\_\_\_\_\_

\_\_\_\_\_

\_\_\_\_\_

\_\_\_\_\_

\_\_\_\_\_

\_\_\_\_\_

\_\_\_\_\_

\_\_\_\_\_

\_\_\_\_\_

\_\_\_\_\_

\_\_\_\_\_

Detailed description (Please use separate sheet)

Please also fax printouts of relevant files such as batch files and configuration files.  
When completed, fax this sheet to the appropriate ATI office. Fax numbers can be found  
on page 41.



Appendix C

# Installation Manual Feedback

---

Please tell us what additional information you would like to see discussed in the manual. If there are topics you would like information on that were not covered in the manual, please photocopy this page, answer the questions and fax or mail this form back to Allied Telesyn. The mailing address and fax number are at the bottom of the page. Your comments are valuable when we plan future revisions of the manual.

On a scale of 1 to 10 (10 being most important), rate the importance of the following topics in this manual:

Overview	_____	Troubleshooting	_____
Hardware Installation	_____	Data Cabling Techniques	_____
Connectivity	_____	Glossary	_____

I found the following the most valuable

\_\_\_\_\_

\_\_\_\_\_

\_\_\_\_\_

I would like the following more developed \_\_\_\_\_

\_\_\_\_\_

\_\_\_\_\_

\_\_\_\_\_

I would find the manual more useful if \_\_\_\_\_

\_\_\_\_\_

\_\_\_\_\_

Please fax or mail your feedback. Fax to 1-206-481-3790. Or mail to:  
**Allied Telesyn Technical Publications Department**  
19015 North Creek Parkway Suite 200  
Bothell, WA 98011 USA





## Appendix D

# Where To Find Us

For Technical Support or Service		
Location	Phone	Fax
<b>North America</b> United States, Canada, Mexico, Central America, South America, Australia, New Zealand	1 (800) 428-4835	1 (206) 481-3790
<b>France</b> France, Belgium, Luxembourg, The Netherlands, Middle East, Africa	(+33) 1-69-28-16-17	(+33) 1-69-28-37-49
<b>Germany</b> Germany, Switzerland, Austria, Eastern Europe	(+01) 30-83-56-66	(+49) 30-435-70-650
<b>Italy</b> Italy, Spain, Portugal, Greece, Turkey, Israel	(+39) 2-38093-444	(+39) 2-38093-448
<b>United Kingdom</b> United Kingdom, Denmark, Norway, Sweden, Finland, Iceland	(+0) 800-20-40-40	(+44) 1-865-390-002
<b>Japan</b>	(+81) 3-3443-5640	(+81) 3-3443-2443
<b>Asia</b> Singapore, Taiwan, Thailand, Malaysia, Indonesia, Korea, Philippines, China, India	(+65) 383-2050	(+65) 383-2079
<b>Hong Kong</b>	(+852) 2-529-4111	(+852) 2 529-7661
<b>Technical Bulletin Board Service</b>	1 (206) 483-7979	
<b>CompuServe</b>	Go ALLIED	
<b>Internet (ftp)</b>	ftp://gateway.centre.com	
<b>World Wide Web</b>	http://www.alliedtelesyn.com	

For Information Regarding Allied Telesyn International Corp.	
<b>Allied Telesyn International Corp.</b> 19015 North Creek Parkway Suite 200 Bothell, WA 98011 Tel: 1 (800) 424-4284 Tel: 1 (206) 487-8880 Fax: 1 (206) 489-9191	<b>Allied Telesyn International Corp.</b> 950 Kifer Road Sunnyvale, CA 94086 Tel: 1 (800) 424-4282 (USA and Canada) Fax: 1 (408) 736-0100

## For Sales Information

**United States**  
**Lilburn, GA**  
 Tel: (404) 717-0290, Fax: (404) 717-0806  
**Salt Lake City, UT**  
 Tel: (801) 350-9130, Fax: (801) 350-9051  
**Vienna, VA**  
 Tel: (703) 506-0196, Fax: (703) 506-1986  
**Chicago, IL**  
 Tel: (708) 406-8431, Fax: (708) 406-8462  
**Austin, TX**  
 Tel: (512) 502-3087, Fax: (512) 794-9326  
**Dallas, TX**  
 Tel: (214) 446-9873, Fax: (214) 446-8555  
**Reading, MA**  
 Tel & Fax: (617) 944-3492  
**Los Angeles, CA**  
 Tel: (310) 412-8684, Fax: (310) 412-8685  
**Costa Mesa, CA**  
 Tel: (714) 432-6424, Fax: (714) 432-6546  
**San Diego, CA**  
 Tel: (619) 279-3896, Fax: (619) 279-3897  
**Clearwater, FL**  
 Tel: (813) 726-0022, Fax: (813) 726-0234

**Turnersville, NJ**  
 Tel: (609) 438-1070, Fax: (609) 468--1201  
**Canada**  
**Mississauga, Ontario**  
 Tel: (905) 803-8626, Fax: (905) 279-0050  
**Richmond, British Columbia**  
 Tel: (604) 244-0678, Fax: (604) 270-3644  
**Germany**  
**Berlin**  
 Tel: (+49) 30-435-9000, Fax: (+49) 30-435-70650  
**Freising**  
 Tel: (+49) 8161-62-002, Fax: (+49) 8161-68-374  
**Lothar Bahn**  
**The Netherlands**  
**Schiphol**  
 Tel: (+31) 20-654-0111, Fax: (+31) 20-654-0270  
**Italy**  
**Milano**  
 Tel: (+39) 2-38093-444, Fax: (+39) 2-38093-448  
**England**  
**Abingdon, Oxon**  
 Tel: (+1) 44-865-390001, Fax: (+1) 44-865-390002

**France**  
**Les Ulis**  
 Tel: (+33) 1-69-28-16-17, Fax: (+33) 1-69-28-37-49  
**Hong Kong**  
**Kowloon**  
 Tel: (+852) 2-393-0101, Fax: (+852) 2-397-7979  
**Wanchai**  
 Tel: (+852) 2-529-4111, Fax: (+852) 2-529-7661  
**Singapore**  
 Tel: (+65) 383-3832, Fax: (+65) 383-3830  
**Japan**  
**Shinagawa-ku, Tokyo**  
 Tel: (+81) 3-3443-5640, Fax: (+81) 3-3443-2443  
**Yodogawa-ku, Osaka**  
 Tel: (+81) 6-391-6310, Fax: (+81) 6-391-6325  
**Fujisawa-shi, Kanagawa**  
 Tel: (+81) 466-88-8510, Fax: (+81) 466-88-8515  
**Machida-shi, Tokyo**  
 Tel: (+81) 427-21-8141, Fax: (+81) 427-21-8848  
**Nagoya-shi, Aichi**  
 Tel: (+81) 52-223-3791, Fax: (+81) 52-223-3736



# Appendix E

## Index

---

### A

#### alarms

- blue 25
- red 25
- yellow 25

#### AT-4016F ports 21

- ATM media interface 21
- RS232 terminal 21
- station 21

#### ATM

- LOS 25
- online 25
- SYNC 25

#### ATM media

- fail 26
- LOS 26
- SYNC 26
- timing 26

#### ATM media port 2

### B

#### Bulletin board service xv

#### bulletin board system (BBS) 14

### C

#### cabling

- 10Base-FL 2, 13
- FOIRL 2
- troubleshooting 29

#### carrier sense multiple access with collision detection (CSMA/CD) 14

#### chassis

- desktop 15

#### compliance

- IEEE 802.3 13, 14

#### CompuServe forum xv

#### connectivity 19

#### connectors

- straight tip (ST) 1, 2
- subscriber channel (SC) 1, 2

### E

#### Electronic xv

#### electronic mail xv

### H

#### hot swapping 17

### I

#### indicators 25, 26

##### ATM media module 26

##### collision 24

##### fiber optic port 24

##### link (amber) 24

##### link (solid green) 24

##### link status 16

##### LOS 29

##### network load 22

##### port 24

##### power 16

##### power supply 23

##### receive 24

##### status 22

#### installation 18

##### installing the unit 16

#### Internet xv

### L

#### location 15

#### loop

##### loop-in 25

##### loop-out 25

#### loss of signal (LOS) 16

### M

#### management agent

##### Omega 16, 21

#### management software

##### upgrading 2

#### memory card

##### PCMCIA 2, 20

##### PCMCIA interface 21

**modules**

- AT-4016F 1, 2, 5
- AT-4016F/SC front panel 19
- ATM media 5, 18
- ATM physical media 5

**P**

**ports**

- media 2

**power supply**

- installing 15, 17

**R**

**replacing power supply 17**

- hot swapping 17

**RS232 serial port 20**

**S**

**serial port 20**

**signaling 2**

**site preparation 15**

**station ports**

- fiber optic 20

**support, contacting technical xv**

**switches 27**

**synchronous optical network (SONET) 2**

**T**

**technical support, contacting xv**

**terminal connector 20**

**troubleshooting 29**

**V**

**ventilation 15**

**W**

**wiring 2, 13, 29**

**wiring practices 14**