

MWS Series

SIMULTANEOUS DUAL BAND WIRELESS ACCESS POINT

AT-MWS600AP

AT-MWS1750AP

AT-MWS2533AP



Installation Guide

Copyright © 2017 Allied Telesis, Inc.

All rights reserved. No part of this publication may be reproduced without prior written permission from Allied Telesis, Inc.

Allied Telesis and the Allied Telesis logo are trademarks of Allied Telesis, Incorporated. All other product names, company names, logos or other designations mentioned herein are trademarks or registered trademarks of their respective owners.

Allied Telesis, Inc. reserves the right to make changes in specifications and other information contained in this document without prior written notice. The information provided herein is subject to change without notice. In no event shall Allied Telesis, Inc. be liable for any incidental, special, indirect, or consequential damages whatsoever, including but not limited to lost profits, arising out of or related to this manual or the information contained herein, even if Allied Telesis, Inc. has been advised of, known, or should have known, the possibility of such damages.

Electrical Safety and Emissions Standards

This product meets the following standards:

Federal Communications Commission Interference Statement

Declaration of Conformity

Manufacturer Name: **Allied Telesis, Inc.**

Declares that the product: **Simultaneous dual band wireless access point**

Model Number: **AT-MWS2533AP**

This device complies with Part 15 of the FCC Rules. Operation is subject to the following two conditions: (1) This device may not cause harmful interference, and (2) this device must accept any interference received, including interference that may cause undesired operation. This equipment has been tested and found to comply with the limits for a Class B digital device, pursuant to Part 15 of the FCC Rules. These limits are designed to provide reasonable protection against harmful interference in a residential installation. This equipment generates, uses and can radiate radio frequency energy and, if not installed and used in accordance with the instructions, may cause harmful interference to radio communications. However, there is no guarantee that interference will not occur in a particular installation. If this equipment does cause harmful interference to radio or television reception, which can be determined by turning the equipment off and on, the user is encouraged to try to correct the interference by one of the following measures:

- Reorient or relocate the receiving antenna.
- Increase the separation between the equipment and receiver.
- Connect the equipment into an outlet on a circuit different from that to which the receiver is connected.
- Consult the dealer or an experienced radio/TV technician for help.



Caution

FCC Caution: Any changes or modifications not expressly approved by the party responsible for compliance could void the user's authority to operate this equipment



Avertissement

Avertissement de la FCC: Les changements ou modifications non expressément approuvés par la partie responsable de la conformité pourraient annuler l'autorité de l'utilisateur à utiliser cet équipement.

This transmitter must not be co-located or operating in conjunction with any other antenna or transmitter.

The band from 5600-5650MHz will be disabled by the software during the manufacturing and cannot be changed by the end user. This device meets all the other requirements specified in Part 15E, Section 15.407 of the FCC Rules.

Radiation Exposure Statement:

This equipment complies with FCC radiation exposure limits set forth for an uncontrolled environment. This equipment should be installed and operated with minimum distance 25cm between the radiator & your body.

Europe - EU Declaration of Conformity

This device complies with Directive 2014/53/EU issued by the Commission of the European Community.

Radiation Explore Statement

This equipment complies with EU radiation exposure limits set forth for an uncontrolled environment. This equipment should be installed and operated with minimum distance 20cm between the radiator & your body.

Operating Frequencies and Maximum Transmission Power Levels

The operating frequencies and maximum transmission power levels for wireless devices operated in the EU are listed below:

	AT-MWS2533AP	AT-MWS1750AP	AT-MWS600AP
2412-2472MHz	19.92 dBm	19.88 dBm	19.42 dBm
5180-5240MHz	22.97 dBm	22.96 dBm	22.40 dBm
5260-5320MHz	22.90 dBm	22.85 dBm	22.24 dBm
5520-5700MHz	29.89 dBm	29.88 dBm	29.65 dBm

This device is restricted to indoor use only when operating in the 5150 to 5350MHz frequency range.

	AT	BE	BG	HR	CY	CZ	DK
	EE	FI	FR	DE	EL	HU	IE
	IT	LV	LT	LU	MT	NL	PL
	PT	RO	SK	SI	ES	SE	UK

Importer:
 Allied Telesis International BV
 Incheonweg 7, 1437 EK Rozenburg

Note

Contact Allied Telesis for the EU conformity statement. To contact Allied Telesis, visit the website at www.alliedtelesis.com/contact.

European Union Restriction of the Use of Certain Hazardous Substances (RoHS) in Electrical and Electronic Equipment

This Allied Telesis RoHS-compliant product conforms to the European Union Restriction of the Use of Certain Hazardous Substances (RoHS) in Electrical and Electronic Equipment. Allied Telesis ensures RoHS conformance by requiring supplier Declarations of Conformity, monitoring incoming materials, and maintaining manufacturing process controls.

Safety and Electromagnetic Emissions Certificates

Standard Compliance

- RoHS compliant
- European Union RoHS (Directive 2011/65/EU of the European Parliament and of the Council of 8 June 2011 on the restriction of the use of certain hazardous substances in electrical and electronic equipment.)

Certificates

- CE
- RCM
- Wi-Fi CERTIFIED

Electromagnetic Interference (EMI)

- EN 55032 Class B
- CISPR 55032

Electromagnetic Compatibility (EMC)

- EN 301 489-1
- EN 301 489-17

Electromagnetic Susceptibility (EMS)

- EN 61000-3-2
- EN 61000-3-3
- IEC 61000-4-2:2008
- IEC 61000-4-3

- ❑ IEC 61000-4-4
- ❑ IEC 61000-4-5
- ❑ IEC 61000-4-6
- ❑ IEC 61000-4-8
- ❑ IEC 61000-4-11

Safety

- ❑ EN 60950-1
- ❑ UL 60950-1, 2nd Edition
- ❑ CAN/CSA-C22.2 No. 60950-1-07, 2nd Edition

Translated Safety Statements

Important: The  indicates that a translation of the safety statement is available in a PDF document titled *Translated Safety Statements* on the Allied Telesis website at www.alliedtelesis.com/support.

Contents

Preface	9
Safety Symbols Used in this Document	10
Contacting Allied Telesis	11
Chapter 1: Product Description	13
Overview	14
AT-MWS600AP and AT-MWS1750AP Models	14
AT-MWS2533AP Model	15
Features	16
Hardware Features	16
Management Features	17
LAN Port	18
Power over Ethernet Plus (PoE+)	18
Connector Type	18
Speed	18
Duplex Mode	18
Automatic MDIX Detection	19
Port Pinouts	19
Redundant Power Supply	20
AT-MWS600AP and	
AT-MWS1750AP Power Supplies	20
AT-MWS2533AP Power Supply	20
LEDs	22
LEDs for	
AT-MWS600AP and	
AT-MWS1750AP Models	22
AT-MWS2533AP	23
Cable Specifications	25
Cable Requirements	25
Maximum Distance	25
Chapter 2: Installing the AT-MWS2533AP Access Point	27
Reviewing Safety Precautions	28
Unpacking the AT-MWS2533AP Access Point	30
Unpacking the AT-BRKT-MWS01 Mounting Base Plate	31
Unpacking the AT-MWS0091 AC Adapter Kit	32
Installing the Access Point on a Ceiling or Wall	34
Guidelines for Installing the Device on a Ceiling or Wall	34
What to Prepare for the Installation	35
Installing the Access Point on the Ceiling or Wall	35
Connecting the Access Point with the Ethernet Cable	38
Connecting the AC Adapter	39
Assembling the AT-MWS0091 AC Adapter	40
Chapter 3: Installing the AT-MWS600AP or AT-MWS1750AP Access Point	43
Unpacking the AT-MWS600AP or AT-MWS1750AP Access Point	44

Installing the Access Point.....	46
Guidelines for Installing the AT-MWS600AP or AT-MWS1750AP Access Point.....	46
Hard-Surface Ceiling and Wall Installation.....	47
Ceiling T-Rail Installation	50
Connecting the Access Point with the Ethernet Cable	53
Connecting the AC Adapter.....	54
Appendix A: Technical Specifications	55
Physical Specifications	55
Environmental Specifications	55
Power Specifications	56
LAN Port.....	57

Preface

This guide contains the hardware installation instructions for the MWS Series Wireless Access Points. The models included in this manual are:

- ❑ AT-MWS600AP
- ❑ AT-MWS1750AP
- ❑ AT-MWS2533AP

This preface contains the following sections:

- ❑ “Safety Symbols Used in this Document” on page 10
- ❑ “Contacting Allied Telesis” on page 11

Safety Symbols Used in this Document

This document uses the following conventions.

Note

Notes provide additional information.



Caution

Cautions inform you that performing or omitting a specific action may result in equipment damage or loss of data.



Warning

Warnings inform you that performing or omitting a specific action may result in bodily injury.

Contacting Allied Telesis

If you need assistance with this product, you may contact Allied Telesis technical support by going to the Support & Services section of the Allied Telesis web site at www.alliedtelesis.com/support. You can find links for the following services on this page:

- ❑ 24/7 Online Support — Enter our interactive support center to search for answers to your product questions in our knowledge database, check support tickets, learn about Return Merchandise Authorizations (RMAs), and contact Allied Telesis technical experts.
- ❑ USA and EMEA phone support — Select the phone number that best fits your location and customer type.
- ❑ Hardware warranty information — Learn about Allied Telesis warranties and register your product online.
- ❑ Replacement Services — Submit an RMA request via our interactive support center.
- ❑ Documentation — View the most recent installation and user guides, software release notes, white papers, and data sheets for your products.
- ❑ Software Downloads — Download the latest software releases for your managed products.

For sales or corporate information, go to www.alliedtelesis.com/purchase.

Chapter 1

Product Description

This chapter describes the hardware components of the MWS series wireless access point. This chapter contains the following sections:

- ❑ “Overview” on page 14
- ❑ “Features” on page 16
- ❑ “LAN Port” on page 18
- ❑ “Redundant Power Supply” on page 20
- ❑ “LEDs” on page 22
- ❑ “Cable Specifications” on page 25

Overview

The MWS series access point is designed to accommodate traffic-intensive applications such as multimedia streaming. The access point is equipped with one or two PoE+ capable LAN ports. With the power supply unit with the DC jack, the PoE+ LAN port provides a redundant power supply system to help uninterrupted operations. This device can be mounted on a ceiling or wall.

The MWS series access point can be installed on a ceiling, wall, or tabletop. In addition, the AT-MWS600AT and AT-MWS1750AP models can be installed on a ceiling T-rail.

AT-MWS600AP and AT-MWS1750AP Models

The AT-MWS600AP and AT-MWS1750AP models are dual band access points with one PoE+ LAN port, which can drain power from the connected PoE+ switch. Both models share the physical design and size. See Figure 1.



Figure 1. Top View of the AT-MWS1750AP Model

The bottom view of the AT-MWS600AP and AT-MWS1750AP models is illustrated in Figure 2.

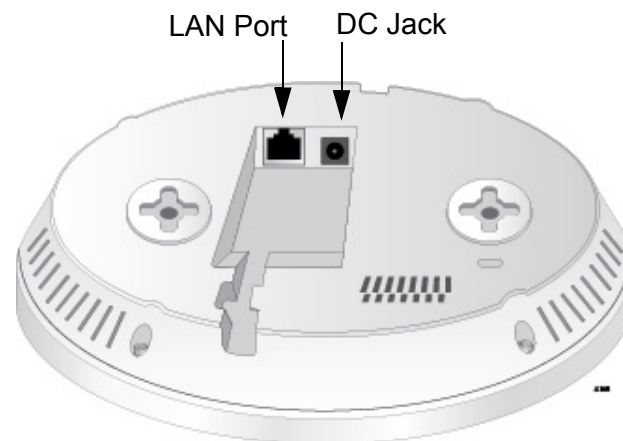

Figure 2. Bottom View of the AT-MWS600AP and 1750AP Models

**AT-MWS2533AP
Model**

The AT-MWS2533AP model is a dual band access point with two PoE+ LAN ports, which can drain power from the connected PoE+ switch. The access point is illustrated in Figure 3.



Figure 3. The Top Panel of the AT-MWS2533AP Model

The front side of the AT-MWS2533AP model is illustrated in Figure 4.

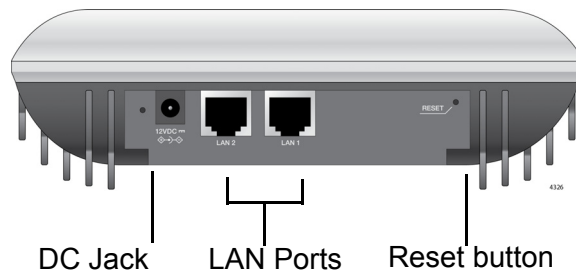

Figure 4. The Front Side View of the AT-MWS2533AP Model

The right side of the AT-MWS2533AP model is illustrated in Figure 5.

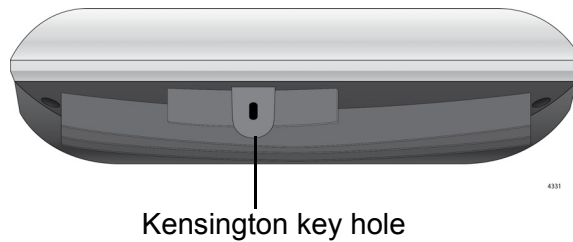

Figure 5. The Right Side View of the AT-MWS2533AP Model

Features

This section lists the main features of the MWS series access points.

Hardware Features

The hardware features for the MWS series access points are listed here:

- ❑ Dual radio: 2.4 GHz and 5 GHz
- ❑ IEEE 802.3 (10Base-T), IEEE 802.3u (100Base-TX), and IEEE 802.3ab (1000Base-T) compliance on the Ethernet port
- ❑ Ceiling, Wall, or table top installation
- ❑ Reset button to revert to the factory default settings

AT-MWS600AP

The features specific to the AT-MWS600AP are listed here:

- ❑ One 10/100/1000Base-T Ethernet port with IEEE802.3at PoE+
- ❑ 2.4GHz 802.11b/g/n (2x2 MIMO) support
- ❑ 5GHz 802.11a/n (2x2 MIMO) support
- ❑ Maximum capacity 2.4 GHz: 300Mbps
- ❑ Maximum capacity 5 GHz: 300Mbps
- ❑ Ceiling T-rail installation

AT-MWS1750AP

The features specific to the AT-MWS1750AP are listed here:

- ❑ One 10/100/1000Base-T Ethernet port with IEEE802.3at PoE+
- ❑ 2.4GHz 802.11b/g/n (3x3 MIMO) support
- ❑ 5GHz 802.11a/n/ac (3x3 MIMO) support
- ❑ Maximum capacity 2.4 GHz: 450Mbps
- ❑ Maximum capacity 5 GHz: 1.3Gbps
- ❑ Ceiling T-rail installation

AT-MWS2533AP

The features specific to the AT-MWS2533AP are listed here:

- ❑ Two 10/100/1000Base-T Ethernet ports with IEEE802.3at PoE+
- ❑ 2.4GHz 802.11b/g/n (4x4 MIMO) support
- ❑ 5GHz 802.11a/n/ac (4x4 MIMO) support

- Maximum capacity 2.4 GHz: 800Mbps
(when using 256QAM modulation scheme)
- Maximum capacity 5 GHz: 1.7Gbps
- Kensington lock support

Management Features

The features to manage the access point are listed here:

- Standalone
- SNMPv1/v2c/v3
- CLI
- SSH
- HTTPS
- Email alert
- Syslog notification

LAN Port

The AT-MWS600AP and AT-MWS1750AP models are equipped with one PoE+ LAN port; The AT-MWS2533AP model is equipped with two PoE+ LAN ports. The LAN port connects the access point to your Local Area Network (LAN), typically through an Ethernet switch. Together with the power supply unit, the LAN port provides a redundant power system. For more information, see “Redundant Power Supply” on page 20.

Power over Ethernet Plus (PoE+)

The MWS series access point supports Power over Ethernet Plus (PoE+) on the LAN port(s). The access point is a PoE+ class 4 powered device and its maximum power consumption is shown below:

- ❑ AT-MWS2533AP model: 21 watts
- ❑ AT-MWS600AP and AT-MWS1750AP models: 11 watts

When the port is connected to a PoE+ Ethernet switch, the access point receives its power over the network cable that carries the network traffic.

Connector Type

The LAN port has an eight-pin RJ45 connector. The port uses four pins at 10 or 100 Mbps and all eight pins at 1000 Mbps. The pin assignments are listed in “LAN Port” on page 57.

Speed

The LAN port can operate at 10, 100, or 1000 Mbps. The speed is set automatically with Auto-Negotiation. You cannot disable Auto-Negotiation on the port.

Note

The LAN port should be connected to a network device that also adjusts its speed with Auto-Negotiation. If the network device does not support Auto-Negotiation, the LAN port operates at 10 Mbps, which may reduce network performance.

Duplex Mode

The LAN port can operate in either half- or full-duplex mode at 10 or 100 Mbps, and full-duplex mode at 1000 Mbps. The port is IEEE 802.3u-compliant and uses Auto-Negotiation to set the duplex mode. (You cannot disable Auto-Negotiation on the port.)

Note

The LAN port should be connected to a network device that also sets its duplex mode with Auto-Negotiation. If the network device does not support Auto-Negotiation, the LAN port operates at half-duplex mode. This may result in a duplex mode mismatch if the network device is operating at full duplex.

**Automatic MDIX
Detection**

The 10/100/1000 Mbps twisted-pair port is IEEE 802.3ab compliant and features automatic MDIX detection when operating at 10 or 100 Mbps. (Automatic MDIX detection does not apply to 1000 Mbps.) This feature automatically configures the port to MDI or MDI-X depending on the wiring configuration of the port on the Ethernet switch.

You may not disable automatic MDIX detection. For automatic MDIX detection to work properly, it must also be present on the Ethernet switch. The LAN port defaults to MDIX if it is connected to a network device that does not support automatic MDIX detection.

Port Pinouts

Refer to Table 13 on page 57 for the port pinouts of the LAN port when it is operating at 10 or 100 Mbps in the MDI configuration and Table 14 on page 58 for the MDI-X configuration. Refer to Table 15 on page 58 for the port pinouts when the port is operating at 1000 Mbps.

Redundant Power Supply

The MWS series access point offers a redundant power supply system. In addition to the power supply through the DC jack, the access point has one or two PoE+ capable LAN ports. When the power supply unit on the access point fails, it switches to the PoE+ port to drain power.

AT-MWS600AP and AT-MWS1750AP Power Supplies

The AT-MWS600AP and AT-MWS1750AP access points are equipped with one PoE+ capable LAN port. The access points can drain power through the DC jack. When power from the DC jack is not available, the access point drains power through the LAN port. Table 1 shows where the AT-MWS600AP and AT-MWS1750AP access points drain power.

Table 1. Power Source for the AT-MWS600AP and AT-MWS1750AP Models

Case	Power Supply		Where the Access Point drains power
	DC Jack	LAN	
1	On	On	The access point drains power through the DC jack. The LAN port is standby.
2	On	-	The access point drains power through the DC jack. No redundancy.
3	-	On	The access point drains power through the LAN port. No redundancy.

AT-MWS2533AP Power Supply

The AT-MWS2533AP access point is equipped with two PoE+ capable LAN ports. The model can drain power through the DC jack. When power from the DC jack is not available, it drains through the LAN2 port; when power is not available through the DC jack or LAN2 port, it drains through the LAN1 port. Table 2 shows where the AT-MWS2533AP model drains power.

Table 2. Power Source for the AT-MWS2533AP Model

Case	Power Supply			Where the Access Point drains power
	DC Jack	LAN1	LAN2	
1	On	On	On	The access point drains power through the DC jack. The both LAN ports are standby.
2	On	On	-	The access point drains power through the DC jack. LAN1 is standby.

Table 2. Power Source for the AT-MWS2533AP Model (Continued)

Case	Power Supply			Where the Access Point drains power
	DC Jack	LAN1	LAN2	
3	On	-	On	The access point drains power through the DC jack. LAN2 is standby.
4	On	-	-	The access point drains power through the DC jack. No redundancy.
5	-	-	On	The access point drains power through the LAN2 port. No redundancy.
6	-	On		The access point drains power through the LAN1 port. No redundancy.
8	-	On	On	The access point drains power through the LAN2 port. LAN1 is standby.



LEDs

The LEDs on the top panel of the MWS series access point display status information.

LEDs for AT-MWS600AP and AT-MWS1750AP Models

The LEDs for the AT-MWS600AP and AT-MWS1750AP access points display status information as shown in Table 3.

Table 3. LEDs for the AT-MWS600AP and AT-MWS1750AP Access Points

LED	State	Description
Power 	Orange	The access power is powered ON and operating normally.
	Off	The access point is <i>not</i> receiving power.
LAN 	Blue	A valid link is established on the port.
	Blinking Blue	Data is being transmitted/received.
	Off	No link is established.
2.4GHz Wi-Fi	Blue	The 2.4GHz Wi-Fi interface is enabled.
	Blinking Blue	Data is being transmitted/received at the 2.4GHz frequency band.
	Off	The 2.4GHz Wi-Fi interface is disabled.
5 GHz Wi-Fi	Green	The 5GHz Wi-Fi interface is enabled.
	Blinking Green	Data is being transmitted/received at the 5GHz frequency band.
	Off	The 5GHz Wi-Fi interface is disabled.
		Not supported.

AT-MWS2533AP

The LEDs for the AT-MWS2533AP model display status information as shown in Table 4.

Table 4. LEDs for the AT-MWS2533AP Access Point





LED	State	Description
Power 	Green	The access point is powered ON and operating normally.
	Blinking Green	The access point is rebooting or software is upgrading.
	Off	The access point is <i>not</i> receiving power.
	Blinking Amber	The configuration has being reset to the factory default settings.
LAN 1 	Green	A valid link is established on the port at 1000Mbps.
	Blinking Green	Data is being transmitted/received at 1000Mbps.
	Amber	A valid link is established on the port at 10Mbps or 100Mbps.
	Blinking Amber	Data is being transmitted/received at 10 Mbps or 100Mbps.
	Off	No link is established.
LAN 2 	Green	A valid link is established on the port at 1000Mbps.
	Blinking Green	Data is being transmitted/received at 1000Mbps.
	Amber	A valid link is established on the port at 10Mbps or 100Mbps.
	Blinking Amber	Data is being transmitted/received at 10 Mbps or 100Mbps.
	Off	No link is established.
2.4GHz Wi-Fi 	Green	The 2.4GHz Wi-Fi interface is enabled.
	Blinking Green	Data is being transmitted/received at the 2.4GHz frequency band.
	Off	The 2.4GHz Wi-Fi interface is disabled.

Table 4. LEDs for the AT-MWS2533AP Access Point (Continued)

LED	State	Description
5GHz Wi-Fi	Green	The 5GHz Wi-Fi interface is enabled.
	Blinking Green	Data is being transmitted/received at the 5GHz frequency band.
	Off	The 5GHz Wi-Fi interface is disabled.

Cable Specifications

To connect the MWS series access point to your LAN, you must provide cables. Here are cable requirements and options.

Cable Requirements

The cable requirements for the LAN port are listed in Table 5.

Table 5. Twisted Pair Cable for the LAN Port

Cable Type	10Mbps	100Mbps	1000Mbps
	PoE+	PoE+	PoE+
Standard TIA/EIA 568-A-compliant Category 5 shielded or unshielded cabling with 100 ohm impedance and 100 MHz frequency.	Yes	Yes	No
Standard TIA/EIA 568-B-compliant Enhanced Category 5 (Cat 5e) shielded or unshielded cabling with 100 ohm impedance and 100 MHz frequency.	Yes	Yes	Yes
Standard TIA/EIA 568-B-compliant Category 6 or 6a shielded cabling.	Yes	Yes	Yes

Maximum Distance

The LAN port has a maximum operating distance of 100 meters (328 feet).

Chapter 2

Installing the AT-MWS2533AP Access Point

This chapter describes how to install the AT-MWS2533AP access point. It contains the following sections:

- ❑ “Reviewing Safety Precautions” on page 28
- ❑ “Unpacking the AT-MWS2533AP Access Point” on page 30
- ❑ “Unpacking the AT-BRKT-MWS01 Mounting Base Plate” on page 31
- ❑ “Unpacking the AT-MWS0091 AC Adapter Kit” on page 32
- ❑ “Installing the Access Point on a Ceiling or Wall” on page 34
- ❑ “Connecting the Access Point with the Ethernet Cable” on page 38
- ❑ “Connecting the AC Adapter” on page 39
- ❑ “Assembling the AT-MWS0091 AC Adapter” on page 40

Note

To install the AT-MWS600AP or AT-MWS1750AP access point, see “Installing the AT-MWS600AP or AT-MWS1750AP Access Point” on page 43.

Reviewing Safety Precautions

Please review the following safety precautions before you begin to install the access point.

Note

The ⚡ indicates that a translation of the safety statement is available in a PDF document titled *Translated Safety Statements* on the Allied Telesis website at www.alliedtelesis.com/support.



Warning

To prevent electric shock, do not remove the cover. No user-serviceable parts inside. This unit contains hazardous voltages and should only be opened by a trained and qualified technician. To avoid the possibility of electric shock, disconnect electric power to the product before connecting or disconnecting the LAN cables.

⚡ E1



Warning

Do not work on equipment or cables during periods of lightning activity. ⚡ E2

Note

All Countries: Install product in accordance with local and National Electrical Codes. ⚡ E8

Note

You should verify that your PoE network adheres to the standards of a separated extra-low voltage (SELV) circuit before using the PoE feature on the wireless access point.



Warning

Only trained and qualified personnel are allowed to install or to replace this equipment. ⚡ E14

**Warning**

This equipment shall be installed in a Restricted Access location.

⚡ E45

**Warning**

Hot Surface, Do Not Touch! - The finned surface on the back of the chassis is a heat sink and can become dangerously hot when the unit is operating. ⚡ E114

**Warning**

To prevent electric shock, slide the AC power plug into the AC/DC power adapter before plugging into the AC power wall receptacles.

⚡ E116

The following warning applies only to the AT-MWS1750AP model:

**Warning**

Operating Temperature. This product is designed for a maximum ambient temperature of 40 degrees C. ⚡ E7

The following warning applies only to the AT-MWS2533AP model:

**Warning**

Operating Temperature. This product is designed for a maximum ambient temperature of 50°C ⚡ E57

Unpacking the AT-MWS2533AP Access Point

To unpack the AT-MWS2533AP access point, perform the following procedure:

1. Remove the AT-MWS2533AP access point from the shipping box.
2. Save the packaging material in a safe location.

You must use the original shipping material if you need to return the unit to Allied Telesis.

Note

To install the AT-MWS2533AP access point on a ceiling or wall, you must purchase the AT-BRKT-MWS01 mounting base plate separately.

Note

To build a redundant power supply system with the power s from the DC jack, you must purchase the AT-MWS0091 AC adapter kits separately.

Unpacking the AT-BRKT-MWS01 Mounting Base Plate

To unpack the AT-BRKT-MWS01 mounting base plate, perform the following procedure:

Note

The AT-BRKT-MWS01 mounting base plate is not included in the AT-MWS2533AP access point package. You must purchase the mounting base plate separately.

1. Remove the AT-BRKT-MWS01 mounting base plate from the shipping box and verify the product. See Figure 6.

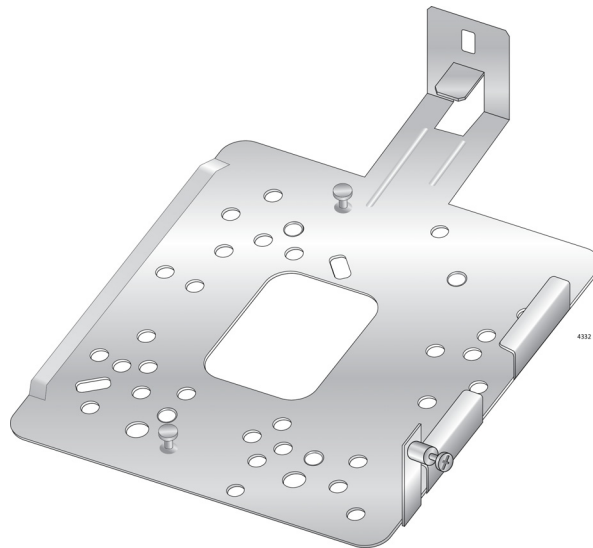

Figure 6. AT-BRKT-MWS01 Mounting Base Plate

2. Save the packaging material in a safe location.

You must use the original shipping material if you need to return the unit to Allied Telesis.

Unpacking the AT-MWS0091 AC Adapter Kit

The AT-MWS0091 AC adapter, which features an interchangeable AC plug, was built with the AC plug for USA when shipped from the factory. You can change the AC plug to another AC plug for Europe, UK, or Australia.

To unpack the AT-MWS0091 AC adapter kit, perform the following procedure:

1. Remove all components from the shipping box.

Note

Store the packaging material in a safe location. You must use the original shipping material if you need to return the unit to Allied Telesis.

2. Verify that all components listed in Table 6 are included in your shipping boxes shown in Table 6.

Table 6. Components in the Shipping Box



Name	Component
AC adapter and plug for USA (APD2-US)	
Plug for UK (APD2-UK)	
Plug for Europe (APD2-EU)	

Table 6. Components in the Shipping Box

Name	Component
Plug for Australia (APD2-AU)	

3. If any item is missing or damaged, contact your Allied Telesis sales representative for assistance.

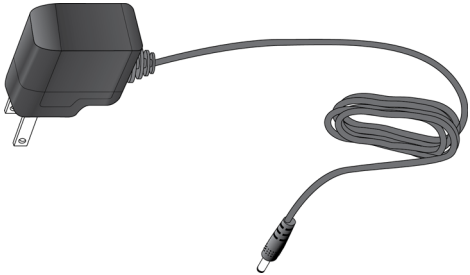
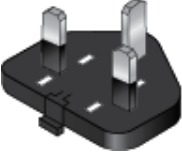
Installing the Access Point on a Ceiling or Wall

The AT-MWS2533AP access point can be mounted on a ceiling or wall.

Guidelines for Installing the Device on a Ceiling or Wall

Review the following guidelines before installing the access point on a ceiling or wall:

- ❑ You must provide the four self-tapping screws that secure the mounting base plate to the ceiling or wall.
- ❑ The ceiling or wall mounting surface must be of proper material to accommodate the self-tapping screws, strong enough to support the weight of the equipment and cables.
- ❑ Connect the Ethernet cable to the access point before installing the access point on the ceiling or wall if connecting the Ethernet cable will be difficult after the access point is installed.
- ❑ The AT-MWS2533AP access point can be installed on a ceiling or tabletop. See Figure 7.

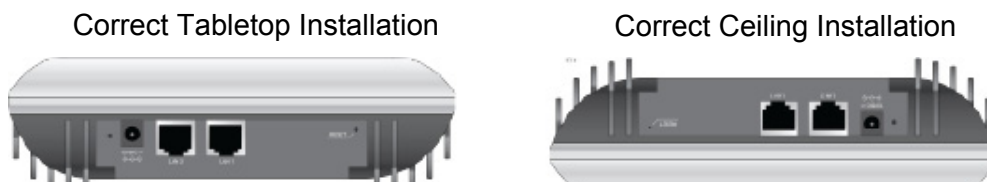

Figure 7. Correct Ceiling or Tabletop Installation

- ❑ The AT-MWS2533AP access point can be mounted on the wall; however, installing the access point with the LAN ports facing up is *not* allowed. See Figure 8 for correct and incorrect wall installation orientations.

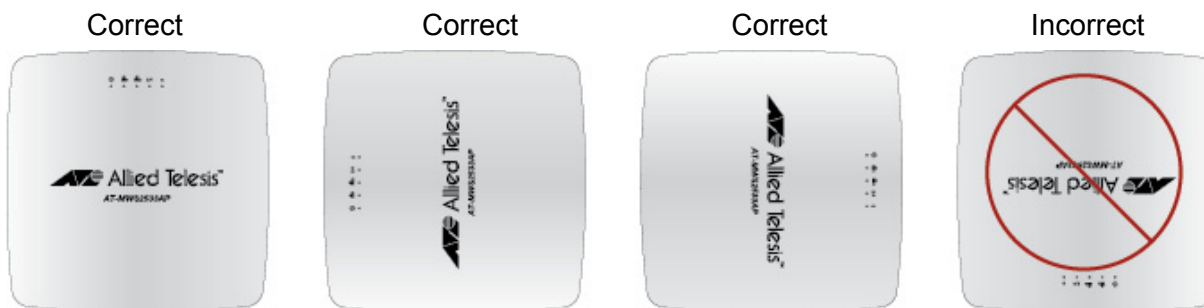

Figure 8. Correct and Incorrect Wall Installation

What to Prepare for the Installation

You need the following items to install the access point on a ceiling or wall:

- AT-MWS2533AP access point
- AT-BRKT-MWS01 Mounting base plate
- Four screws for a ceiling or wall
- Phillips-head screwdriver
- Pencil

Note

Screws for the ceiling or wall, a Phillip-head screwdriver and pencil are *not* included in the shipping box.

Installing the Access Point on the Ceiling or Wall

To install the access point on the ceiling or wall, perform the following procedure:

Note

Attaching the access point to the mounting base plate may not be easy once the mounting base plate is installed on a ceiling or wall. Practice Step 5 to Step 7 before installing the mounting base plate on a ceiling or wall.

1. Review “Guidelines for Installing the Device on a Ceiling or Wall” on page 34.
2. Using the mounting base plate as a template, mark the four holes with a pencil.
3. Pre-drill the marked locations on the ceiling or wall.
4. Install the mounting base plate on the ceiling or wall as shown in Figure 9 on page 36.

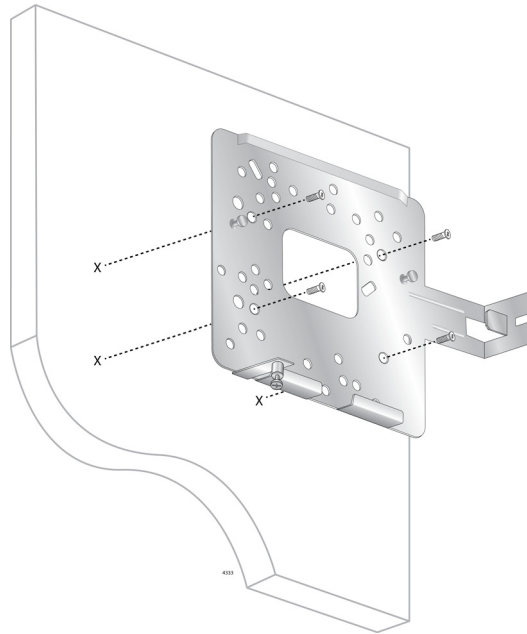

Figure 9. Installing the Mounting Base Plate on the Ceiling or Wall

5. Insert the two pins on the mounting base plate into the circles of the keyhole slots, as shown in Figure 10.

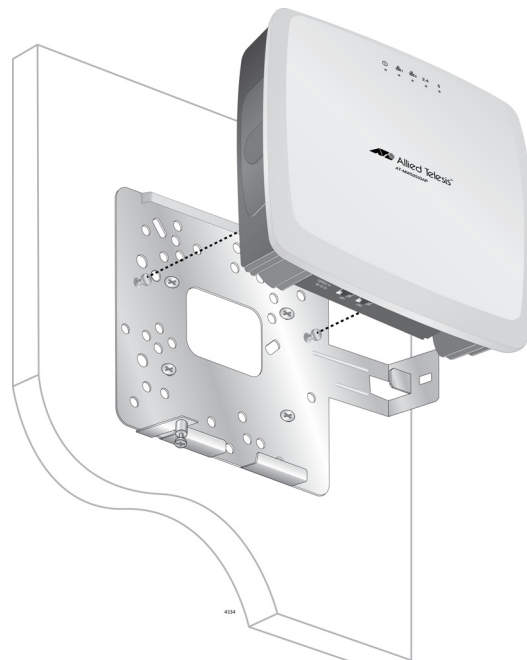

Figure 10. Aligning the Access Point with the Mounting Base Plate

6. Slide the access point to lock the necks of the mounting base plate pins in the slots, as shown in Figure 11 on page 37.

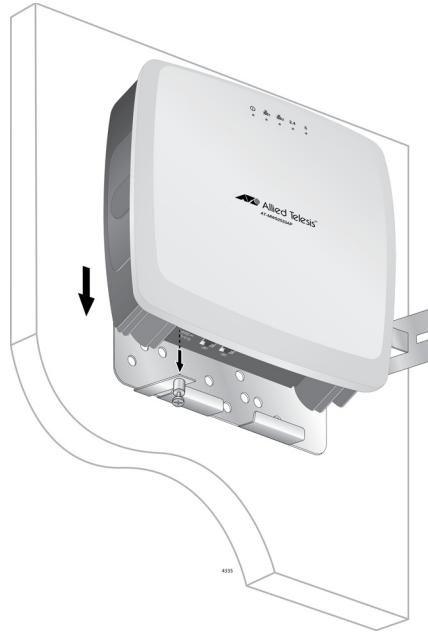

Figure 11. Sliding the Access Point to Secure the Mounting Base Plate

7. Fasten the captive screw on the mounting base plate to secure the access point.

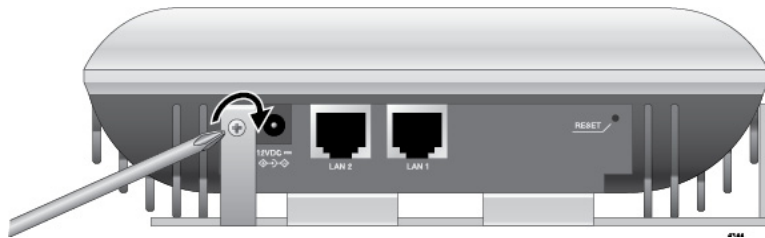

Figure 12. Fastening the Captive Screw to Secure the Access Point

Connecting the Access Point with the Ethernet Cable

To connect the access point with the Ethernet cable, perform the following procedure:

1. Connect the RJ-45 plug into the LAN port as shown in Figure 13.

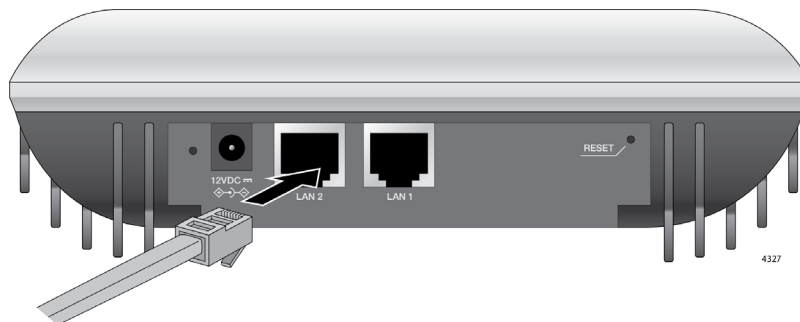

Figure 13. Connecting the LAN Cable

2. Connect the other RJ-45 plug to the PoE+ switch.

Connecting the AC Adapter

To connect the AC adapter, perform the following procedure:

1. Connect the AC adapter into the DC jack on the access point as shown in Figure 14.

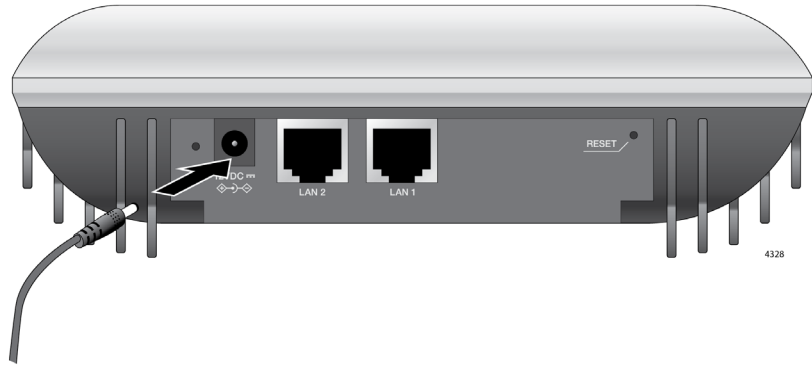

Figure 14. Connecting the LAN Cable and Attaching the Sealing Nut

2. Connect the other end of the AC adapter to wall power outlet.

Assembling the AT-MWS0091 AC Adapter

The AT-MWS0091 AC adapter is shipped with the AC plug for USA attached. When the AC socket on your wall is other than the USA type, you can change it to another AC plug for Europe, UK, or Australia.

To change the AC plug on the AT-MWS0091 AC adapter, perform the following procedure:

1. Select one from the optional AC plugs. See Table 6 on page 32.
2. While pressing the release tab with your thumb, slide the AC plug as shown in Figure 15.

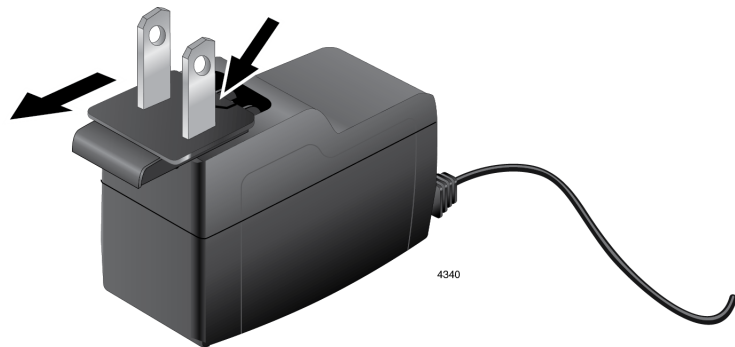

Figure 15. Detaching the AC Plug from the AC Adapter

3. Remove the AC plug from the AC adapter as shown in Figure 16.

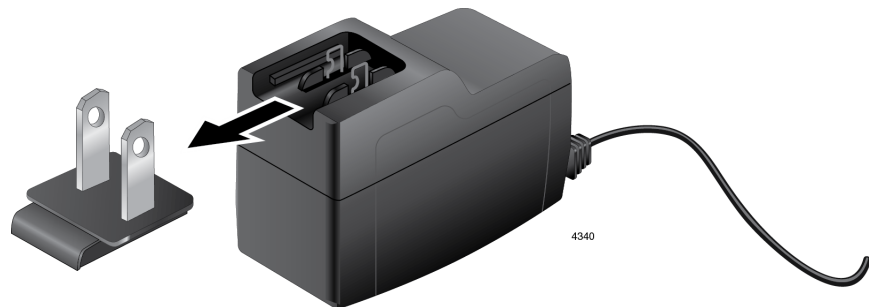

Figure 16. Removing the AC Plug from the AC Adapter

4. Attach the AC plug that you selected to the AC adapter in shown in Figure 17 on page 41.

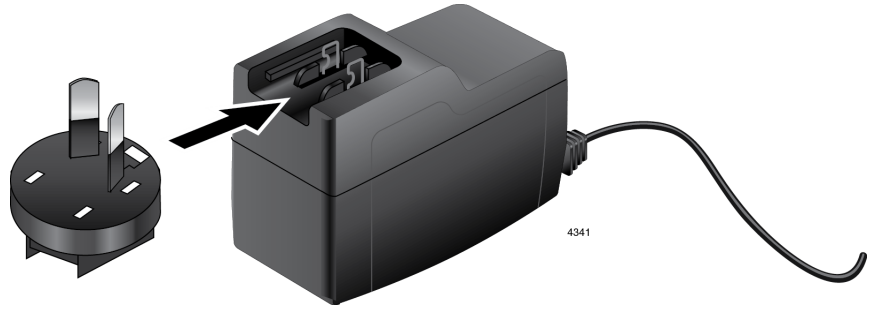

Figure 17. Attaching the AC Plug to the AC Adapter



Warning

To prevent electric shock, slide the AC power plug into the AC/DC power adapter before plugging into the AC power wall receptacles.

⚡ **E116**

Chapter 3

Installing the AT-MWS600AP or AT-MWS1750AP Access Point

This chapter describes how to install the AT-MWS600AP or AT-MWS1750AP access point. It contains the following sections:

- ❑ “Unpacking the AT-MWS600AP or AT-MWS1750AP Access Point” on page 44
- ❑ “Installing the Access Point” on page 46
- ❑ “Connecting the Access Point with the Ethernet Cable” on page 53
- ❑ “Connecting the AC Adapter” on page 54

Note

To install the AT-MWS2533AP access point, see “Installing the AT-MWS2533AP Access Point” on page 27.

Unpacking the AT-MWS600AP or AT-MWS1750AP Access Point

To unpack the AT-MWS600AP or AT-MWS1750AP access point, perform the following procedure:

1. Remove all components from the shipping boxes.

Note

Store the packaging material in a safe location. You must use the original shipping material if you need to return the unit to Allied Telesis.

2. Verify that all components listed in Table 7 are included in your shipping boxes.

Table 7. Components in the Shipping Boxes





	Name	Component
Mounting base kit	1 x Mounting base	
	2 x Screw for the mounting base (M2.6 9.8mm)	

Table 7. Components in the Shipping Boxes (Continued)

	Name	Component
Rail clip kit	2 x Narrow rail clip	
	2 x Wide rail clip	
	2 x Spacer	
	2 x Short screw to attach a rail clip without the spacer or attach to the access point directly	
	2 x Long screw to attach a rail clip with the spacer	

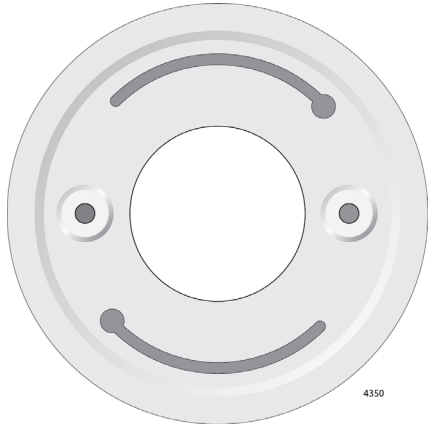
3. If any item is missing or damaged, contact your Allied Telesis sales representative for assistance.

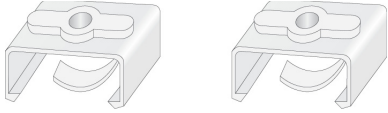
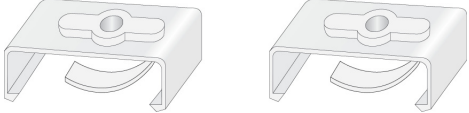
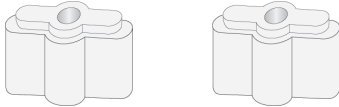
Installing the Access Point

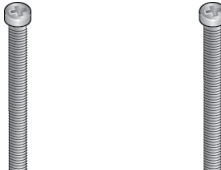
Guidelines for Installing the AT-MWS600AP or AT-MWS1750AP Access Point

The AT-MWS600AP and AT-MWS1750AP access points can be mounted on a table, wall, hard-surface ceiling, or ceiling rail.

Review the following guidelines before installing the access point:

- ❑ The ceiling or wall mounting surface must be of proper material to accommodate the screws, strong enough to support the weight of the access point and cables.
- ❑ The ceiling rail must be strong enough to support the weight of the access point and cables.
- ❑ Ensure the cables are long enough to connect to the places you planned before installing the access point. Once the access point is installed, it may be difficult to change the cables.
- ❑ Connect the Ethernet cable and power code to the access point before installing the access point on the ceiling or wall. Connecting the Ethernet cable and power code may be difficult after the access point is installed.
- ❑ The access points can be installed on a table and ceiling. See Figure 18 for correct orientations.

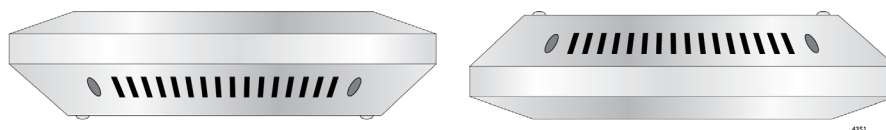

Figure 18. Correct Orientation on a Tabletop and Ceiling

- ❑ The access point must be mounted on the wall in the orientations shown in Figure 19. In other orientations, the access point cannot have a proper air flow.

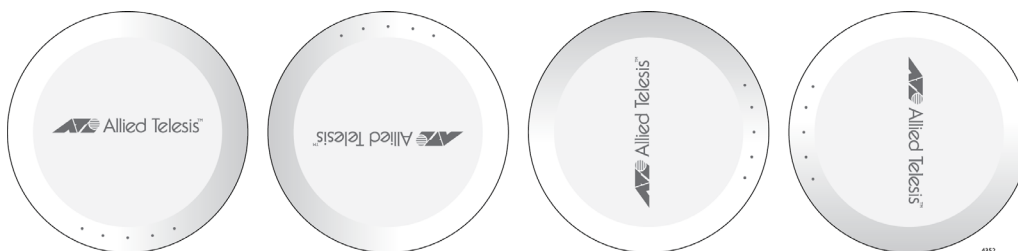

Figure 19. Correct Orientations on a Wall

- ❑ The access point can be attached to installed on two types of suspended ceiling T-rails. Select one of the ceiling grip clips in the shipping box for your ceiling rail.

Hard-Surface Ceiling and Wall Installation

This section explains how to install the access point on the hard-surface ceiling or wall.

What to Prepare for the Hard-Surface Ceiling or Wall Installation

You need the following items to install the access point on a ceiling or wall:

- AT-MWS600AP or AT-MWS1750AP access point
- Two screws to attach to the access point directly
- Mounting base
- Two screws for the mounting base
- Phillips-head screwdriver
- Pencil

Note

A Phillip-head screwdriver and pencil are *not* included in the shipping box.

Installing the Access Point on the Hard-Surface Ceiling or Wall

To install the access point on the hard-surface ceiling or wall, perform the following procedure:

Note

Attaching the access point to the mounting base may not be easy once the mounting base is installed on the hard-surface ceiling or wall. Practice Step 12 and Step 13 before installing the mounting base on a hard-surface ceiling or wall.

1. Read “Reviewing Safety Precautions” on page 28.
2. Review “Guidelines for Installing the AT-MWS600AP or AT-MWS1750AP Access Point” on page 46.

3. Attach the two screws to the access point, as shown in Figure 20.

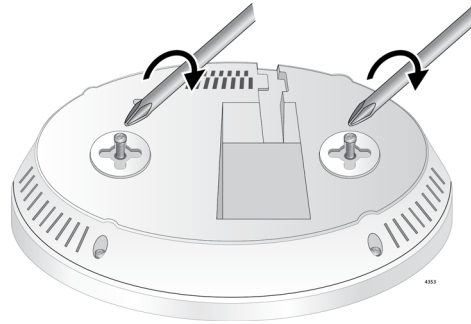

Figure 20. Attaching the Screws to the Access Point

4. Apply the mounting base to the access point and adjust the height of the screws where the access point can be turned to be secured to the mounting base as shown in Figure 21.

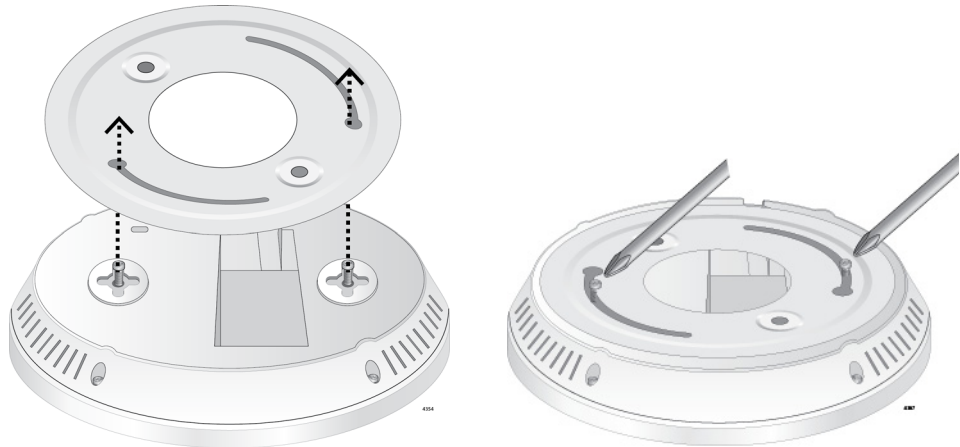

Figure 21. Adjusting the Screws on the Access Point

5. Remove the mounting base from the access point. See Figure 22.

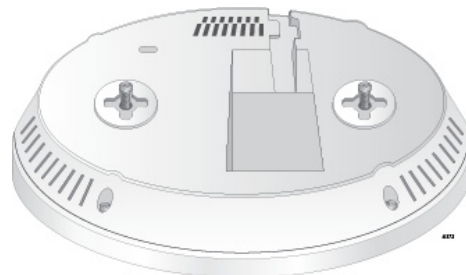

Figure 22. The Access Point with Two Screws Attached

6. Connect an Ethernet cable. See “Connecting the Access Point with the Ethernet Cable” on page 53.

Note

Ensure the cable is long enough to connect the access point to the place where you planned. Once the access point is installed, it may be difficult to change the cable.

7. If you plan to use the AC adapter, connect it. See “Connecting the AC Adapter” on page 54.

Note

Ensure the power outlet is in the reach. Once the access point is installed, it may be difficult to change the location.

8. If you are installing the access point on the wall, ensure that the orientation of the mounting base is correct.
9. Using the mounting base as a template, mark the two holes with a pencil where you want to install the access point. See Figure 23.

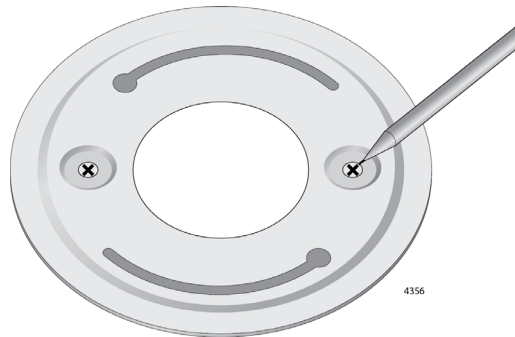

Figure 23. Marking the Mounting Base Holes

10. Pre-drill the marked locations on the hard-surface ceiling or wall.
11. Install the mounting base on the hard-surface ceiling or wall as shown in Figure 24.

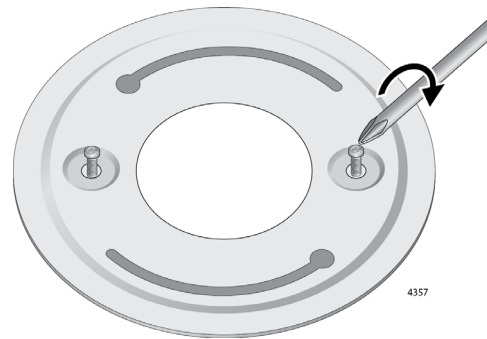

Figure 24. Installing the Mounting Base on a Hard-Surface Ceiling or Wall

12. Insert the two screws on the access point to the holes on the mounting base, as shown in Figure 25.

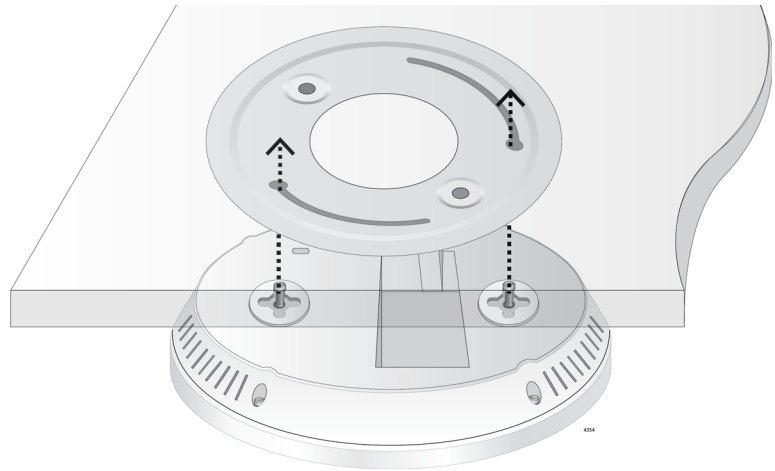

Figure 25. Installing the Access Point onto a Ceiling or Wall

13. Turn the access point until it is securely seated. See Figure 26.



Figure 26. Turning the Access Point to Secure to the Mounting Base

Ceiling T-Rail Installation

To install the access point on the ceiling T-rail, perform the following procedure:

What to Prepare for the Rail Installation

You need the following items to install the access point on a ceiling or wall:

- AT-MWS600AP or AT-MWS1750AP access point
- Two rail clips, either narrow rail clips or wide rail clips
- Two spacers
- Two long screws for the rail clip with the spacer
- Phillips-head screwdriver

Note

A Phillip-head screwdriver is *not* included in the shipping box.

Installing the Access Point on the Ceiling T-Rail

To install the access point on the ceiling T-rail, perform the following procedure:

1. Read “Reviewing Safety Precautions” on page 28.
2. Review “Guidelines for Installing the AT-MWS600AP or AT-MWS1750AP Access Point” on page 46.
3. Attach two rail clips and the spacers to the access point using the long screws as shown in Figure 27.

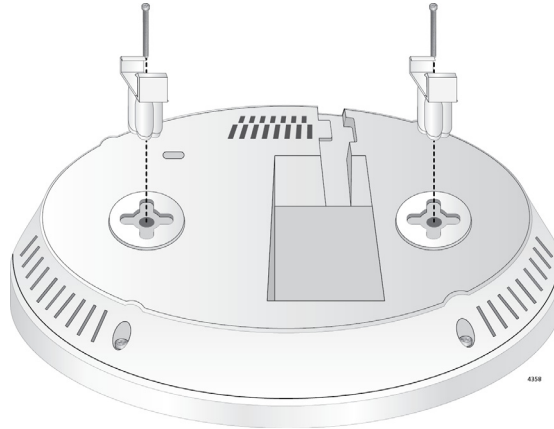

Figure 27. Attaching the Rail Clips and Spacers to the Access Point

4. Connect an Ethernet cable. See “Connecting the Access Point with the Ethernet Cable” on page 53.

Note

Ensure the cable is long enough to connect the access point to the place where you planned. Once the access point is installed, it may be difficult to change the cable.

5. If you plan to use the AC adapter, connect it. See “Connecting the AC Adapter” on page 54.

Note

Ensure the power outlet is in the reach. Once the access point is installed, it may be difficult to change the location.

6. Align the rail clips on the access point to the ceiling T-rail and apply force to attach the access point to the rail, as shown in Figure 28.

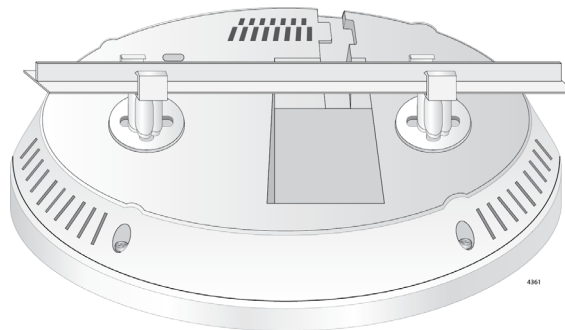

Figure 28. Attaching the Access Point to the Ceiling T-rail

Connecting the Access Point with the Ethernet Cable

To connect the access point with the Ethernet cable, perform the following procedure:

1. Connect the RJ-45 plug into the LAN port as shown in Figure 29.

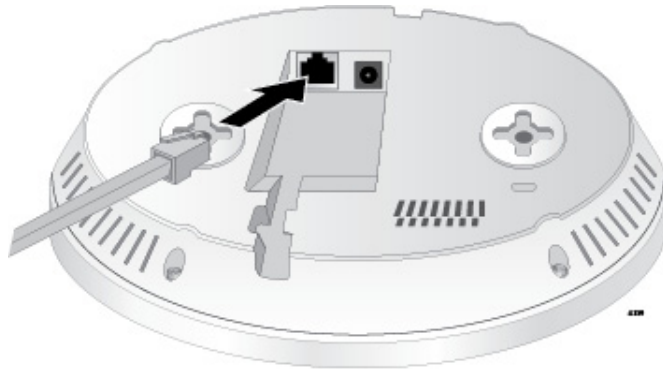

Figure 29. Connecting the LAN Cable

2. Connect the other RJ-45 plug to the PoE+ switch.

Connecting the AC Adapter

To connect the AC adapter, perform the following procedure:

1. Connect the AC adapter into the DC jack on the access point as shown in Figure 30.

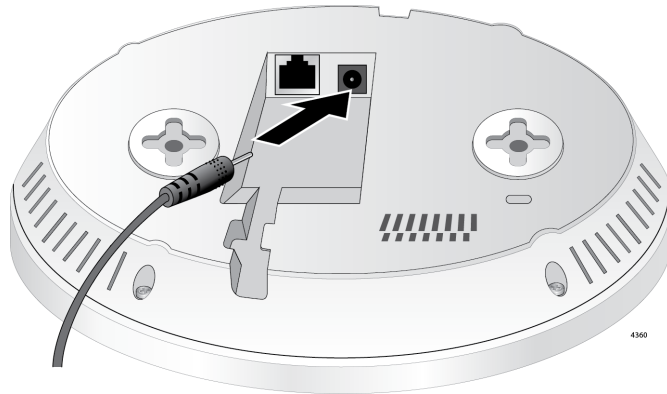

Figure 30. Connecting the AC Adapter

2. Connect the other end of the AC adapter to wall power outlet.

Appendix A

Technical Specifications

This appendix contains the following sections:

- ❑ “Physical Specifications”
- ❑ “Environmental Specifications”
- ❑ “Power Specifications” on page 56
- ❑ “LAN Port” on page 57

Physical Specifications

Table 8. Product Dimensions

Model	Dimensions	Weight
AT-MWS600AP	161 mm x 161 mm x38 (6.3 in. x 6.3in. x 1.5in.)	280g (0.62 lb.)
AT-MWS1750AP	161 mm x 161 mm x38 (6.3 in. x 6.3in. x 1.5in.)	340g (0.75 lb.)
AT-MWS2533AP	215 mm x 215 mm x 56 mm (8.5 in. x 8.5 in. x 2.2 in.)	1.6kg (3.5 lb.)
Power adapter	N/A	130g (0.29 lb.)

Environmental Specifications

AT-MWS2533AP

Table 9. Environmental Specifications

Operating Temperature of the Access Point	0° C to 50° C (32° F to 122° F)
Operating Temperature of the AC adapter	0° C to 45° C (32° F to 113° F)
Storage Temperature	-40° C to 70° C (-40° F to 158° F)
Operating Humidity	5% to 90% non-condensing

Table 9. Environmental Specifications

Storage Humidity	5% to 95% non-condensing
------------------	--------------------------

AT-MWS600AP and AT-MWS1750AP

Table 10. Environmental Specifications

Operating Temperature of the Access Point	0° C to 40° C (32° F to 104° F)
Storage Temperature	-20° C to 60° C (-4° F to 140° F)
Operating Humidity	10% to 80% non-condensing
Storage Humidity	10% to 95% non-condensing

Power Specifications

Maximum Power Consumptions

Table 11. Maximum Power Consumptions

Model	Max Power Consumption
AT-MWS2533AP	21 watts
AT-MWS600AP AT-MWS1750AP	11 watts

LAN Port

Table 12. LAN Port Specifications

Connector	RJ45
Standards	IEEE 802.3 (10Base-T) IEEE 802.3u (100Base-TX) IEEE 802.3ab (1000Base-T)
PoE standard	IEEE 802.3at (class 4)

Figure 31 illustrates the pin layout of the LAN port.

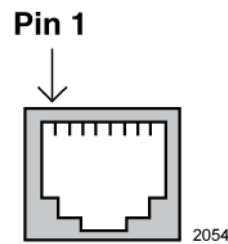

Figure 31. Pin Layout for the RJ45 Connector on the LAN Port

Table 13 lists the pin signals when the port is operating in the MDI configuration at 10 or 100 Mbps.

Table 13. MDI Pin Signals (10Base-T or 100Base-TX)

Pin	Signal
1	TX+
2	TX-
3	RX+
6	RX-

Table 14 lists the pin signals for the MDI-X configuration at 10 or 100 Mbps.

Table 14. MDI-X Pin Signals (10Base-T or 100Base-TX)

Pin	Signal
1	RX+
2	RX-
3	TX+
6	TX-

Table 15 lists the pin signals when the LAN port is operating at 1000 Mbps.

Table 15. 1000Base-T Connector Pinouts

Pin	Pair	Signal
1	1	TX and RX
2	1	TX and RX-
3	2	TX and RX+
4	3	TX and RX+
5	3	TX and RX-
6	2	TX and RX-
7	4	TX and RX+
8	4	TX and RX-