

How To | Power over Ethernet

Introduction

Power over Ethernet (PoE) is a technology allowing devices such as IP telephones to receive power over existing LAN cabling.

This technical note is in four parts as follows:

- PoE Technology
- How PoE works
- Allied Telesyn PoE implementation
- Command Reference

What information will you find in this document?

The first two parts of this document describe the PoE technology, and the installation and management advantages that PoE can provide. This is followed by an overview of how PoE works, Power Device(PD) discovery, PD classification, and the delivery of power to PD data cables. The third part of this document focuses on Allied Telesyn's implementation of PoE on the AT-8624PoE switch. The document concludes with a list of configuration and monitoring commands.

Which product and software version does this information apply to?

The information provided here applies to:

- Products: AT8624PoE switch
- Software version: 2.6.5

PoE Technology

Power over Ethernet is a mechanism for supplying power to network devices over the same cabling used to carry network traffic. PoE allows devices that require power, called Powered Devices (PDs), such as IP telephones, wireless LAN Access Points, and network cameras to receive power in addition to data, over existing infrastructure without needing to upgrade it. This feature can simplify network installation and maintenance by using the switch as a central power source for other network devices.

A device that can source power such as an Ethernet switch is termed Power Sourcing Equipment (PSE). Power Sourcing Equipment can provide power, along with data, over existing LAN cabling to Powered Devices.

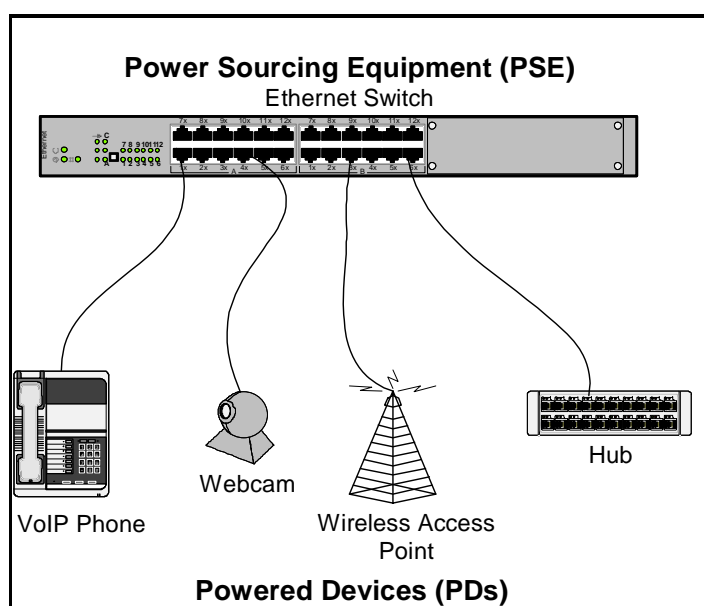

The advantage of PoE

Most network devices require both a data connection and a power supply. Just as standard telephones are supplied power and also communicate over the same wiring, now the same provision can be made for Ethernet network devices.

Some of the advantages of PoE include:

- A single cable between switch and Powered Device (PD)
- No separate power installation/ connection needed for PD's
- Simplified installation and space saving
- Device placement is not limited to nearby power sources
- PD's can be easily moved to wherever there is LAN cabling
- Safety - no mains voltages anywhere
- A UPS can guarantee power to devices even during mains failure
- Devices can be shut down or reset remotely
- Little configuration or management required

PoE devices

There are increasing numbers of PoE devices becoming available. The more common uses for PoE are for communication devices such as VoIP phones and wireless LAN access points. There are however, quite a variety of devices now taking advantage of PoE technology such as:

- VoIP phones
- Wireless access points
- Ethernet hubs
- Digital clocks
- Webcams
- Security cameras
- Intercoms
- Building access systems
- Even a network electric guitar
- Plus others...

PoE standard

The Institute of Electrical and Electronics Engineers (IEEE) standardization process involves experts from many companies, and provides standards for network equipment and protocols that help retain conformance across the networking industry.

The PoE IEEE 802.3af standard was formally approved by the IEEE Standards Board in June 2003 and is an amendment to the existing IEEE 802.3 standards.

How PoE works

PoE requires little configuration or management. The PSE automatically determines whether a device connected to a port is a powered device or not, and can determine the power class of the device. The PSE can supply up to 15.4 watts of power (at 48 Volts) to the device, while at the same time providing standard Ethernet network functionality.

Lets look at these concepts in a little more detail:

Power Device (PD) discovery

The first step for PSE equipment (an Ethernet switch for example) is to ascertain whether a device plugged into a port is a valid Powered Device (PD). If it is, it will require power as well as network communication through the attached LAN cable.

The IEEE 802.3af-2003 standard for device detection involves applying a DC voltage between the transmit and receive wire pairs, and measuring the received current. A PSE will expect to see approximately 25K Ohm resistance and 150nF capacitance between the pairs for the device to be considered a valid PD. A range around these values is specified in the IEEE 802.3ad standard.

The PSE will check for the presence of PD's on connected ports at regular intervals, so power is removed when a PD is no longer connected.

Power classes

Once a PD is discovered, a PSE may optionally perform PD classification by applying a DC voltage and current to the port. If the PD supports optional power classification it will apply a load to the line to indicate to the PSE the classification the device requires.

The power classes as outlined by IEEE 802.3af are as follows:

Class	Power Usage
0	0.44W to 12.95W
1	0.44W to 3.84W
2	3.84W to 6.49W
3	6.49W to 12.95W
4	Reserved for future use

Once the PSE has detected the PD's IEEE 802.3af power class, the PSE can manage the power allocation by subtracting the PD's class maximum value from the overall power budget. This allows for control and management of power allocation when there is not enough power available from the PSE to supply maximum power to all ports.

Any unclassified PD is considered to be a class 0 device.

The IEEE 802.3af standard supports delivery of up to 15.4 watts per port that may be used to deliver power to PoE devices. This allows quite a variety of possible devices to make use of the available power.

The maximum power consumed by a PD, as specified by the standard, is 12.95 watts. The system provides the 'extra' power (up to 15.4 watts) to compensate for line loss.

Some common PoE device power requirements are:

Device	Power Requirement
IP phone	3-6 watts
Wireless access point	4-11 watts
IP security camera	5-12 watts

Power through the cable

An Ethernet cable (CAT5) has four twisted pairs, but only two of these are used for data transfer, (10/100BASE-TX). The IEEE 802.3af standard allows two options for using these cables for power supply as follows:

- The spare pairs are used. In this case the unused pairs are used to transfer the power.
- The data pairs are used. Since Ethernet pairs are transformer coupled at each end, it is possible to apply DC power to the centre tap of the isolation transformer without upsetting the data transfer.

The following diagram shows an example of power applied over the data pairs:

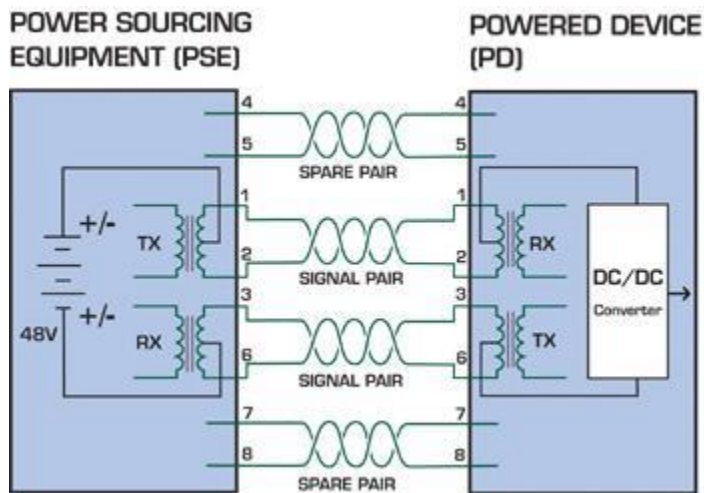

Power supplied over the data pins

The IEEE 802.3af standard does not allow both sets of wires to be used, so a choice must be made. Different vendors PSE equipment may use one or other of the methods to supply power depending on PoE implementation. So the PSE applies power to either the spare or data wires. The Powered Device (PD) must be able to accept power from both options.

The voltage supplied is nominally 48V, and a maximum of 12.95W of power is available at the Powered Device. An isolated DC-DC converter transforms the 48V to a lower voltage more suitable for the electronics in the Powered Device.

Allied Telesyn PoE implementation

This section is based around the PoE implementation in the new Allied Telesyn AT-8624PoE switch. The AT-8624PoE is a wire speed Layer 3 fast Ethernet switch.

PoE hardware

The AT-8624PoE switch has a PoE specific chipset inside which performs the various PoE management tasks and is monitored by the switch CPU. This is made up of two PowerDsine IC's, which carry out the following functions:

The PD-64012 IC implements all real time activities according to the IEEE 802.3af standard, including: detection, classification, and port status monitoring. There are two 64012 IC's in the AT-8624PoE providing PoE functionality to 12 ports each.

The PD-63000 is an 8-bit microcontroller unit (MCU). The 63000 manages the two 64012 IC's to free the 8624 switches CPU from this additional task. The AT-8624PoE CPU monitors the 63000 MCU.

Power capacity

The PSU in the AT-8624PoE supplies enough power for the switch itself, and has 400 watts available for PoE provision.

The maximum possible power requirement (24 ports * 15.4W = 370 watts) falls below the maximum amount of power available (400 watts). This means that you can connect powered devices to all the ports on the switch (excluding optional expansion ports) without having to be concerned about exceeding the available power, even if all the PD's require the maximum 15.4 watts.

You can reduce the amount of power a port can source, from the maximum of 15.4 W, using the command:

```
set poe [port={port-list|ALL}] [priority={low|high|critical}]
      [powerlimit=value]
```

However, configuring the power limit on the switch will probably not be necessary. As already mentioned, the power supply in the switch can provide enough power to meet the needs of all 24 10/100 base ports, even if they all require the maximum 15.4 watts for connected PD's.

Power threshold

The switch sends a Simple Network Management Protocol (SNMP) trap to your management workstation and enters an event in the event log whenever the total power requirements of the powered devices exceed the specified percentage of the total maximum power available on the switch. At the default setting of 95%, the switch sends an SNMP trap when the PoE devices require more than 95% of the maximum available power on the switch.

You can adjust the threshold using the command:

```
set poe threshold=value
```

For your management workstations to receive traps from the switch, you must configure SNMP on the switch by specifying the IP address of the workstations. The switch will also enter an event in the event log whenever power consumption of the switch has returned below the power limit threshold.

Power through the cable

As mentioned earlier, the IEEE 802.3af standard describes two methods for implementing PoE over twisted pair cabling. One method uses the same cables that carry the network traffic and the other the spare pairs. The PoE implementation on the AT-8624PoE switch transmits power over the same pairs that carry the network traffic (pairs 1 & 2 and 3 & 6).

PoE port management

PoE on the AT-8624PoE switch is enabled by default on all 24 10/100 ports. PoE can be administratively enabled or disabled on each port using the commands:

```
DISable POE [Port={port-list|ALL}]
```

```
ENable POE [Port={port-list|ALL}]
```

When PoE is disabled on a port, the port will operate as a normal Ethernet port without delivering the power to the connected device.

The user can connect either a PD or a non-PD device to a PoE-enabled port without reconfiguring the port, as PD detection is carried out before any power is supplied to the connected device.

Powered Device (PD) detection

The Allied Telesyn implementation of PoE offers two methods of PD detection. The default is to use the IEEE 802.3af standard resistance and capacitance measurements as described earlier. The second option is to support legacy PD's that were designed before the IEEE standard was finalised. This involves measuring for a large capacitance value to confirm the presence of a PD.

The PD detection method can be set with the command:

```
SET POE DETECT={IEEE|LEGacy}
```

In legacy mode, the IEEE method will be tried first and failing the discovery of a valid PD the legacy capacitance measurement will be tried.

PD detection is carried out in real-time by the PSE controller on each switch port to detect and monitor the presence of any powered devices. Power is not supplied to any specific port until a valid PD is detected. A switch port which has a PD unplugged, will cease to have power supplied.

Powered Device (PD) classification

The Allied Telesyn PoE implementation also includes the optional PD power classification measurement. This is undertaken after PD detection has confirmed a valid PD is attached to a specific port. The value returned by the power classification measurement is shown when you enter the command **show switch port**, but the port is not limited to the classification.

Power Class detection could be used more in future Allied Telesyn products, which are not capable of supplying the maximum 15.4 watts of power to all ports simultaneously. In this case a 'power budget' can be implemented to manage how much power is used and how much is still available. For example, if a device only requires up to 6.5 watts (power class 2) then only this amount is supplied and taken from the switches total power budget.

Port prioritisation

Port prioritisation is the way the switch determines which ports are to receive power in the event that the needs of the PD's exceeds the available power resources of the switch.

Note: *This discussion does not apply to the AT-8624PoE switch, since its power supply can deliver the maximum of 15.4 W to all 24 10/100 based ports simultaneously. This discussion becomes relevant only if, at some later date, Allied Telesyn releases a switch with PoE capability that has a power supply that cannot service all ports simultaneously.*

If the PD's connected to a switch require more power than the switch is capable of delivering, the switch will deny power to some ports based on a system called port prioritisation. You can use port prioritisation to ensure that PD's critical to the operations of your network are given preferential treatment by the switch in the distribution of power, should the demands of the devices exceed the available capacity.

There are three priority levels:

- Critical
- High
- Low

You can set the port priority using the command:

```
set poe [port={port-list|ALL}] [priority={critical|high|low|}]  
    [powerlimit=value]
```

Critical is the highest priority level. Ports set to this level are guaranteed power before any ports assigned to the other two priority levels. Ports assigned to the other priority levels receive power only if all the Critical ports are receiving power. Your most critical powered devices should be assigned to this level. If there is not enough power to support all the ports set to the Critical priority level, power is provided to the ports based on port number, in ascending order.

High is the second highest level. Ports set to this level receive power only if all the ports set to the Critical level are already receiving power. If there is not enough power to support all of the ports set to the High priority level, power is provided to the ports based on port number, in ascending order.

Low is the lowest priority level. This is the default setting. Ports set to this level only receive power if all the ports assigned to the other two levels are already receiving power. As with the other levels, if there is not enough power to support all of the ports set to the Low priority level, power is provided to the ports based on port number, in ascending order.

Power allocation is dynamic. Ports supplying power to PD's may cease power transmission if the switch's power capacity has reached maximum usage and new PD's connected to ports with a higher priority, become active.

Visual monitoring

As with other Allied Telesyn switches, there are two LED's on the front panel, which indicate link status/ activity and duplex mode.

Figure 1: The front panel of the AT-8624PoE



With the AT-8624PoE, there is an additional option to have the duplex LED indicate PoE information. There is a 'mode' switch to set whether this LED will show Duplex or PoE information.

If PoE information is selected, this LED indicates whether a Powered Device is connected, fault condition, and maximum current reached. The LED states in PoE mode are shown below:

PoE Mode	OFF	There is no powered device detected
PD On	Green	The end node is a powered device and the port is providing power to it
PD Error	Red	The port is experiencing a problem providing PoE to the end node
Max Current	Flashing Red	The port is connected to a powered device but providing power to it would exceed the maximum PoE power budget of the switch

Software monitoring

There are three 'show' commands available which return information about the PoE settings on the AT-8624PoE switch.

The 'show switch port=x' command has some additional parameters added, specifying whether PoE is enabled on the port and any power limit and priority that have been set.

The 'show poe' command details power threshold set, a power usage percentage, and power consumed by each switch port.

The 'show poe port=x' command details the PoE information for a specified port, including power limit, power consumed, power class...

Note: All PoE commands are fully detailed in the command reference section following.

Command Reference

The following commands are available for configuring and monitoring PoE on the AT-8624PoE switch:

disable poe port

Syntax `DISable POE [Port={port-list|ALL}]`

Description This command disables PoE on a port. The port continues to provide standard Ethernet connectivity even when PoE is disabled. PoE is enabled by default.

The **port** parameter specifies a port number, a range of port numbers (specified as n-m), or a comma-separated list of port numbers and/or ranges. Port numbers start at 1 and end at 24. The **all** parameter disables PoE on all ports.

Examples To disable PoE on ports 5 and 7, use the command:

```
disable poe port=5,7
```

enable poe port

Syntax `ENable POE [Port={port-list|ALL}]`

Description This command enables PoE on a port. PoE is enabled by default.

The **port** parameter specifies a port number, a range of port numbers (specified as n-m), or a comma-separated list of port numbers and/or ranges. Port numbers start at 1 and end at 24. The **all** parameter disables PoE on all ports.

Examples To enable PoE on port 2, use the command:

```
enable poe port=2
```

set poe detect

Syntax `SET POE DETect={IEEE|LEGacy}`

Description The PoE detect mode allows selection of one of the two modes. In IEEE mode, only IEEE standard detection is enabled. This is according to IEEE 802.3af standard in which a valid resistance and capacitance is used for detecting a valid PD.

In LEGacy mode, IEEE detection is first implemented and only if it fails then legacy detection is used, wherein a large capacitance value is used to detect a legacy PD. This mode is used to support legacy devices. The default mode is IEEE mode.

Examples To set the detection mode to legacy mode, use the command:

```
set poe detect=legacy
```

set poe port

Syntax SET POE [Port={*port-list*|ALL}]
[POWerlimit=*value*] [PRIOrity={low|high|critical}]

Description This command sets the PoE settings on a port.

Parameter	Description
port	Sets PoE on a specific port number, a range of port numbers (specified as nm), or a comma-separated list of port numbers and/or ranges. Port numbers start at 1 and end at 24. Specifying all sets PoE on all ports.
priority	Determines which ports receive PoE when powered device consumption exceeds the available power resources of the switch. One of Low , High , or Critical . Default: Low
powerlimit	The maximum amount of power (in milliwatts) a powered device can draw from the port.

Default: **15400mW** (15.4W)

Examples To set the priority on ports 6 and 11 to high, use the command:

```
set poe port=6,11 priority=high
```

To set the maximum power on port 14 to 12,500 mW, use the command:

```
set poe port=14 powerlimit=12500
```

set poe threshold

Syntax SET POE THReshold=*value*

Where threshold is specified as a percentage of the total amount of PoE available. The range is 1 to 100

Description The switch sends an SNMP trap to the management workstation and enters an event in the event log when the total power requirements of the powered devices exceeds the specified percentage of the total maximum power available on the switch. The switch sends an SNMP trap when the PoE devices require more than 95% (the default) of the maximum available power on the switch. The threshold is adjustable.

Examples To set the threshold to 80% of the available power, use the command:

```
set poe threshold=80
```

Example output from the SHOW PoE command:

show poe

Syntax SHoW POE [PORT={*port-list*|ALL}]

Where port specifies a port number, a range of port numbers (specified as n-m), or a comma-separated list of port numbers and/or ranges. Port numbers start at 1 and end at 24.

Description This command displays information about Power over Ethernet for the specified port or ports. If no port number is specified, summary information about all PoE ports is displayed. If a port, or range of ports is specified, more detailed information is displayed. If all is specified, detailed information about all Power over Ethernet ports is displayed

```
Manager > show poe

PoE Global Power Status:

Max Available Power...400 W
Power Threshold.....95 percent
Consumed Power.....0 W
Available Power.....400 W
Power Usage.....0.00 percent
Power Detect Mode.....IEEE
Min Shutdown Voltage...44.0 V
Max Shutdown Voltage...57.0 V

PoE All Ports Power Status Summary:

Port    PoE Status    Consumed Power (mW)    Power State
-----
1       ENABLED      0                      OFF - Detection in process
2       ENABLED      0                      OFF - Detection in process
3       ENABLED      0                      OFF - Detection in process
4       ENABLED      0                      OFF - Detection in process
5       ENABLED      0                      OFF - Detection in process
6       ENABLED      0                      OFF - Detection in process
7       ENABLED      0                      OFF - Detection in process
8       ENABLED      0                      OFF - Detection in process
9       ENABLED      0                      OFF - Detection in process
10      ENABLED      0                      OFF - Detection in process
11      ENABLED      0                      OFF - Detection in process
12      ENABLED      0                      OFF - Detection in process
13      ENABLED      0                      OFF - Detection in process
14      ENABLED      0                      OFF - Detection in process
15      ENABLED      0                      OFF - Detection in process
16      ENABLED      0                      OFF - Detection in process
17      ENABLED      0                      OFF - Detection in process
18      ENABLED      0                      OFF - Detection in process
19      ENABLED      0                      OFF - Detection in process
20      ENABLED      0                      OFF - Detection in process
21      ENABLED      0                      OFF - Detection in process
22      ENABLED      0                      OFF - Detection in process
23      ENABLED      0                      OFF - Detection in process
24      ENABLED      0                      OFF - Detection in process
```

USA Headquarters | 19800 North Creek Parkway | Suite 100 | Bothell | WA 98011 | USA | T: +1 800 424 4284 | F: +1 425 481 3895
European Headquarters | Via Motta 24 | 6830 Chiasso | Switzerland | T: +41 91 69769.00 | F: +41 91 69769.11
Asia-Pacific Headquarters | 11 Tai Seng Link | Singapore | 534182 | T: +65 6383 3832 | F: +65 6383 3830
www.alliedtelesis.com

© 2009 Allied Telesis, Inc. All rights reserved. Information in this document is subject to change without notice. Allied Telesis is a trademark or registered trademark of Allied Telesis, Inc. in the United States and other countries. All company names, logos, and product designs that are trademarks or registered trademarks are the property of their respective owners.