



613-000297 Rev. D



AT-CV1KSS Converteon Line Card Installation Guide

Overview

The AT-CV1KSS line card is a dual 1000Base-TX SFP line card. You can install this line card in any Converteon Series chassis. The line card features two small form factor pluggable (SFP) transceiver slots. The line card is hot-swappable into and out of a Converteon chassis.

Related Documents

For details on the features and functions of a Converteon chassis, refer to the relevant documents on our web site, www.alliedtelesis.com.

Verifying Package Contents

Ensure that the following items are included in your package:

- One AT-CV1KSS line card
- This installation guide

If any item is missing or damaged, contact your Allied Telesis sales representative for assistance.

AT-CV1KSS Line Card Components

An AT-CV1KSS line card has the components shown below.

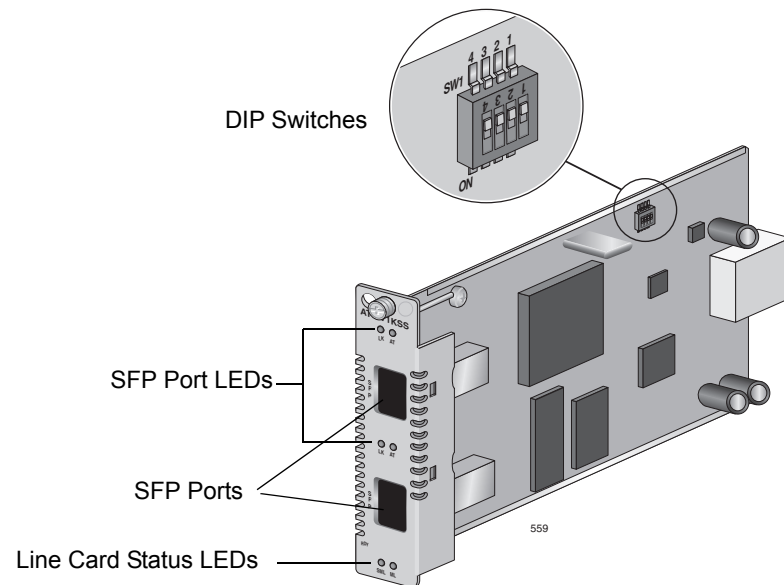

SFP Ports Description

The SFP ports support an SFP transceiver with a fixed operating speed of 1000 Mbps.

LEDs

The AT-CV1KSS line card has three status LEDs and two LEDs for each SFP port, as described in "LED Descriptions."

DIP Switches

One set of DIP switches allows you to set the operating mode, as described in "DIP Switch Settings."

Installing an AT-CV1KSS Line Card

Note

Before you install an AT-CV1KSS line card, refer to the appropriate Converteon chassis installation guide for electrical safety and emissions information.



Warning: Remove all metal jewelry, such as rings and watches, before installing or removing a line card from a powered-on chassis.

Caution: Be sure to observe all standard electrostatic (ESD) precautions, such as wearing an antistatic wrist strap, to avoid damaging the device. A line card can be damaged by static electricity

Note

You can install a Converteon line card in any Converteon chassis line card slot.

To install an AT-CV1KSS line card, perform the following procedure:

1. Remove the AT-CV1KSS line card from its shipping package and store the package in a safe place. You must use the original package if you need to return the unit to Allied Telesis.
2. Configure the line card's DIP switches as required. Refer to "DIP Switch Settings" for more information.
3. Select any line card slot in the chassis where you want to install the AT-CV1KSS line card, and remove the blank slot cover if one is installed.
4. Align the back edge of the line card with the top and bottom alignment guides located inside the slot.
5. Slide the line card into the slot until the front of the card is flush with the front of the chassis.

Note

Avoid touching the line card components.

6. Secure the AT-CV1KSS line card to the chassis by using a Phillips screwdriver to tighten the captive screw on the faceplate.

Note

Always tighten the captive screw to secure the line card to the chassis.

7. Repeat this procedure to install additional AT-CV1KSS line cards.

LED Descriptions

Status LEDs

The line card has four status LEDs as described in the following table. For more information about Smart MissingLink and MissingLink, refer to the relevant management software user's guide.

LED	State	Description
RDY	Green	The line card has passed diagnostics.
	Off	The line card has not passed diagnostics.
SML	Green	The Smart MissingLink mode is enabled.
	Off	The Smart MissingLink mode is disabled.
ML	Green	The MissingLink mode is enabled.
	Off	The MissingLink mode is disabled.

SFP Port LEDs

Each SFP port has two LEDs, as described in the following table. For more information about Smart MissingLink, refer to the relevant management software user's guide.

LED	State	Description
LK	Green	A link has been established on the port.
	Blinking Green	While in Smart MissingLink mode, a valid connection is established on the port while a link on the other port is lost.
	Off	No link has been established on the port.
AT	Blinking Green	TX/RX activity has been detected on the port.
	Off	There is no TX/RX activity on the port.

DIP Switch Settings

The DIP switches described in the following table allow you to set the operating mode of the line card. For information about the operating modes as well as Smart MissingLink and MissingLink, refer to the relevant management software user's guide.

Operating Mode	DIP 1	DIP 2	DIP 3	DIP 4
Smart MissingLink (SML)	OFF	ON	ON	X
MissingLink (ML)	OFF	OFF	ON	X
Link Test (default)	OFF	OFF	OFF	X
Manufacturing Defaults	OFF	OFF	OFF	X

"X" means that the DIP switch position can be ON or OFF.

Warranty Information

The AT-CV1KSS line card has a limited warranty of five years. Go to www.alliedtelesis.com/warranty for the specific terms and conditions of the warranty and for warranty registration.

Specifications

Dimensions (H x W x L)	2.2 cm x 7.3 cm x 13.0 cm (.78 in. x 2.89 in. x 5.1 in.)
Weight	0.27 kg (0.60 lbs.)
Operating Temperature	0° C to 40° C (32° F to 104° F)
Storage Temperature	-25° C to 70° C (-13° F to 158° F)
Operating Relative Humidity	5% to 90% (non-condensing)
Storage Relative Humidity	5% to 95% (non-condensing)
Operating Altitude Range	Up to 3,048 m (10,000 ft.)
Predicted MTBF (Telcordia SR332)	1,370,000 hours
Power Consumption	4.75 Watts maximum

Electrical Safety and Emissions Statements

This product meets the following standards when installed in compliant host equipment.

U.S. Federal Communications Commission

Radiated Energy

Note: This equipment has been tested and found to comply with the limits for a Class A digital device pursuant to Part 15 of FCC Rules. These limits are designed to provide reasonable protection against harmful interference when the equipment is operated in a commercial environment. This equipment generates, uses, and can radiate radio frequency energy and, if not installed and used in accordance with this instruction manual, may cause harmful interference to radio communications. Operation of this equipment in a residential area is likely to cause harmful interference in which case the user will be required to correct the interference at his own expense.

Note: Modifications or changes not expressly approved of by the manufacturer or the FCC, can void your right to operate this equipment.

Industry Canada

This Class A digital apparatus meets all requirements of the Canadian Interference-Causing Equipment Regulations.
Cet appareil numérique de la classe A respecte toutes les exigences du Règlement sur le matériel brouilleur du Canada.

Emissions FCC Class A, EN55022 Class A, VCCI Class A, C-TICK, CE

Warning: In a domestic environment this product may cause radio interference in which case the user may be required to take adequate measures.

Immunity EN55024

Electrical Safety UL60950 (cUL_{US}), EN60950 (TUV), CSA22.2 No. 950

Copyright © 2007 Allied Telesis, Inc. All rights reserved.

No part of this publication may be reproduced without prior written permission from Allied Telesis, Inc.

