

# MMC6000 Series

## VDSL Mini Media Converters

- ❑ MMC6005
- ❑ MMC6006



# Installation Guide

Copyright © 2020 Allied Telesis, Inc.

All rights reserved. No part of this publication may be reproduced without prior written permission from Allied Telesis, Inc.

Allied Telesis and the Allied Telesis logo are trademarks of Allied Telesis, Incorporated. All other product names, company names, logos or other designations mentioned herein are trademarks or registered trademarks of their respective owners.

Allied Telesis, Inc. reserves the right to make changes in specifications and other information contained in this document without prior written notice. The information provided herein is subject to change without notice. In no event shall Allied Telesis, Inc. be liable for any incidental, special, indirect, or consequential damages whatsoever, including but not limited to lost profits, arising out of or related to this manual or the information contained herein, even if Allied Telesis, Inc. has been advised of, known, or should have known, the possibility of such damages.

# Electrical Safety and Emissions Standards

---

This section contains the following:

- "Federal Communications Commission Interference Statement"
- "European Union Restriction of the Use of Certain Hazardous Substances (RoHS) in Electrical and Electronic Equipment" on page 4
- "Emissions, Immunity and Electrical Safety Standards" on page 5
- "Translated Safety Statements" on page 5

This product meets the following standards:

## Federal Communications Commission Interference Statement

---

### Declaration of Conformity

Manufacturer Name: **Allied Telesis, Inc.**

Declares that the product: **VDSL Mini Media Converter**

Model Number: **MMC6000 Series**

This device complies with Part 15 of the FCC Rules. Operation is subject to the following two conditions: (1) This device may not cause harmful interference, and (2) this device must accept any interference received, including interference that may cause undesired operation.

This equipment has been tested and found to comply with the limits for a Class B digital device, pursuant to Part 15 of the FCC Rules. These limits are designed to provide reasonable protection against harmful interference in a residential installation. This equipment generates, uses and can radiate radio frequency energy and, if not installed and used in accordance with the instructions, may cause harmful interference to radio communications. However, there is no guarantee that interference will not occur in a particular installation. If this equipment does cause harmful interference to radio or television reception, which can be determined by turning the equipment off and on, the user is encouraged to try to correct the interference by one of the following measures:

- Reorient or relocate the receiving antenna.
- Increase the separation between the equipment and receiver.
- Connect the equipment into an outlet on a circuit different from that to which the receiver is connected.
- Consult the dealer or an experienced radio/TV technician for help.

**Caution**

FCC Caution: Any changes or modifications not expressly approved by the party responsible for compliance could void the user's authority to operate this equipment. ⚡ E80

---

**Avertissement**

Avertissement de la FCC: Les changements ou modifications non expressément approuvés par la partie responsable de la conformité pourraient annuler l'autorité de l'utilisateur à utiliser cet équipement. ⚡ E80

---

This transmitter must not be co-located or operating in conjunction with any other antenna or transmitter.

The band from 5600-5650MHz will be disabled by the software during the manufacturing and cannot be changed by the end user. This device meets all the other requirements specified in Part 15E, Section 15.407 of the FCC Rules.

**Radiation Exposure Statement:**

This equipment complies with FCC radiation exposure limits set forth for an uncontrolled environment. This equipment should be installed and operated with minimum distance 32cm between the radiator & your body.

---

## **European Union Restriction of the Use of Certain Hazardous Substances (RoHS) in Electrical and Electronic Equipment**

---

This Allied Telesis RoHS-compliant product conforms to the European Union Restriction of the Use of Certain Hazardous Substances (RoHS) in Electrical and Electronic Equipment. Allied Telesis ensures RoHS conformance by requiring supplier Declarations of Conformity, monitoring incoming materials, and maintaining manufacturing process controls.

## Emissions, Immunity and Electrical Safety Standards

---

RFI Emissions    FCC Class B, EN55022 Class B, CISPR 22 Class B, VCCI Class B, C-TICK

---



### Warning

In a domestic environment this product may cause radio interference in which case the user may be required to take adequate measures. ⚡ E84

---

EMC (Immunity)    EN55024, EN61000-3-2, EN61000-3-3

Electrical Safety    EN60950-1 (TUV), UL 60950-1 (CULUS)

---



### Warning

Laser Safety: EN60825 ⚡ L7

---

## Translated Safety Statements

---

**Important:** The ⚡ indicates that a translation of the safety statement is available in a PDF document titled *Translated Safety Statements* on the Allied Telesis website at [www.alliedtelesis.com/support](http://www.alliedtelesis.com/support).



# Contents

---

<b>Preface</b> .....	13
Document Conventions.....	14
Contacting Allied Telesis.....	15
<b>Chapter 1: Product Description</b> .....	17
Introduction .....	18
Summary of Features.....	19
Overview .....	20
Location of Components .....	21
Feature Description.....	22
VDSL Line Port.....	22
VDSL2 Profiles and Settings .....	23
10/100/1000 Mbps Twisted Pair Ethernet Port.....	26
Type of Cabling .....	26
Auto MDI/MDI-X.....	26
Auto-Negotiation .....	26
Half- and Full-duplex Mode .....	27
Status LEDs.....	27
DIP Switches .....	29
Subscriber or Provider Configuration.....	29
VDSL2 Configuration .....	30
Smart Missing Link (SML) Configuration.....	30
Smart MissingLink™ (SML).....	31
SML Overview.....	31
SML Example.....	31
DC Power Supply Input Port.....	32
External AC/DC Power Adapter .....	32
<b>Chapter 2: Installation</b> .....	33
Installation Safety Precautions.....	34
Selecting a Site for the Media Converter .....	36
Cables Not Included.....	37
Unpacking the Media Converter.....	38
Installing the Subscriber Unit .....	39
Using the Subscriber Unit on a Desktop.....	39
Wall-Mounting the Subscriber Unit.....	39
Setting the Subscriber Unit DIP Switches .....	40
Cabling the Subscriber Unit.....	40
Powering On the Subscriber Unit .....	42
Installing the Provider Unit .....	43
Using the Provider Unit on a Desktop .....	44
Wall-Mounting the Provider Unit.....	44
Rack Mounting the Provider Unit.....	44
Setting the Provider Unit DIP Switches .....	45
Cabling the Provider Unit.....	46
Powering On the Provider Unit .....	47
<b>Chapter 3: Troubleshooting</b> .....	49

<b>Appendix A: Technical Specifications</b> .....	51
Physical Specifications .....	51
Environmental Specifications .....	51
Power Specifications .....	52
Safety and Electromagnetic Emissions Certifications .....	52
RJ45 Connector and Port Pinouts .....	53
<b>Appendix B: AT-MMCWLMT Kit Installation</b> .....	55



# Figures

---

<b>Figure 1:</b> Media Converter System Topology .....	20
<b>Figure 2:</b> MMC6005 Front Panel .....	21
<b>Figure 3:</b> MMC6006 Front Panel .....	21
<b>Figure 4:</b> MMC6000 Series Rear Panel.....	21
<b>Figure 5:</b> DIP Switch 1: Subscriber / Provider Unit Configuration .....	29
<b>Figure 6:</b> DIP Switches 2, 3, 4: VDSL2 Profile Configuration (Provider Only) .....	30
<b>Figure 7:</b> DIP Switch 5 - SML Configuration .....	30
<b>Figure 8:</b> SML in Normal Condition with Two Media Converters .....	31
<b>Figure 9:</b> SML with Copper Connection to End Node Down .....	32
<b>Figure 10:</b> Subscriber Unit - Installing Feet .....	39
<b>Figure 11:</b> Subscriber Unit DIP Switch Position .....	40
<b>Figure 12:</b> Subscriber Unit Ethernet Port to Computer .....	41
<b>Figure 13:</b> Subscriber Unit DSL Port to DSL Line in Building .....	41
<b>Figure 14:</b> Subscriber Unit - Connecting 12VDC Power Adapter .....	42
<b>Figure 15:</b> Provider Unit - Installing Feet.....	44
<b>Figure 16:</b> Provider Unit DIP Switch Position .....	45
<b>Figure 17:</b> Provider Unit Ethernet Port to Internet Service Provider.....	46
<b>Figure 18:</b> Provider Unit to Wall Plug or Interior VDSL Line in Building .....	46
<b>Figure 19:</b> Provider Unit - Connecting 12VDC Power Adapter .....	47
<b>Figure 20:</b> RJ45 Connector and Port Pin Layout.....	53
<b>Figure 21:</b> Attaching the Brackets to the Media Converter .....	56
<b>Figure 22:</b> Wall-mount Template .....	56
<b>Figure 23:</b> Placing the Template on the Wall.....	57
<b>Figure 24:</b> Securing the Media Converter to the Wall.....	58



# Tables

---

<b>Table 1:</b> MMC6005 RJ11 VDSL Port Pinouts .....	22
<b>Table 2:</b> VDSL2 DIP Switch Settings - Profiles, Description, Usage .....	24
<b>Table 3:</b> VDSL2 DIP Switch Settings - Additional Information .....	25
<b>Table 4:</b> Twisted-Pair Port Cabling Specifications .....	26
<b>Table 5:</b> Status LEDs .....	27
<b>Table 6:</b> Cables .....	37
<b>Table 7:</b> MMC6000 Series Accessory Kit .....	38
<b>Table 8:</b> Physical Specifications .....	51
<b>Table 9:</b> Environmental Specifications .....	51
<b>Table 10:</b> Power Specifications .....	52
<b>Table 11:</b> Safety and Electromagnetic Emissions Certifications .....	52
<b>Table 12:</b> MDI Pin Signals (10 or 100 Mbps) .....	53
<b>Table 13:</b> MDI-X Pin Signals (10 or 100 Mbps) .....	53
<b>Table 14:</b> Pin Signals (1000 Mbps) .....	54
<b>Table 15:</b> AT-MMCR WLMT Kit Contents .....	55



# Preface

---

This preface contains the following sections:

- “Document Conventions” on page 14
- “Contacting Allied Telesis” on page 15

This guide contains instructions on how to install and configure the MMC6000 Series Media Converters.

# Document Conventions

---

This document uses the following conventions:

---

**Note**

Notes provide additional information.

---

**Caution**

Cautions inform you that performing or omitting a specific action may result in equipment damage or loss of data.

---

**Warning**

Warnings inform you that performing or omitting a specific action may result in bodily injury.

---

## Contacting Allied Telesis

---

If you need assistance with this product, you may contact Allied Telesis technical support by going to the Support & Services section of the Allied Telesis web site at [www.alliedtelesis.com/support](http://www.alliedtelesis.com/support). You can find links for the following services on this page:

- ❑ 24/7 Online Support — Enter our interactive support center to search for answers to your product questions in our knowledge database, to check support tickets, to learn about RMAs, and to contact Allied Telesis technical experts.
- ❑ USA and EMEA phone support — Select the phone number that best fits your location and customer type.
- ❑ Hardware warranty information — Learn about Allied Telesis warranties and register your product online.
- ❑ Replacement Services — Submit a Return Merchandise Authorization (RMA) request via our interactive support center.
- ❑ Documentation — View the most recent installation and user guides, software release notes, white papers, and data sheets for your products.
- ❑ Software Downloads — Download the latest software releases for your managed products.

For sales or corporate information, select your region and country, then go to [www.alliedtelesis.com/contact](http://www.alliedtelesis.com/contact).





## Chapter 1

# Product Description

---

This chapter describes the following media converters:

- MMC6005
- MMC6006

This chapter contains the following sections:

- “Introduction” on page 18
- “Summary of Features” on page 19
- “Overview” on page 20
- “Location of Components” on page 21
- “Feature Description” on page 22

## Introduction

---

The MMC6000 Series VDSL Mini Media Converter is designed to transmit data at very high speeds over unshielded pairs of copper wires using VDSL2 technology. They also can extend the distance of your network by interconnecting LAN devices that are physically separated by large distances. They are easy to install and do not require any software configuration or management.

The difference between the MMC6005 and the MMC6006 models is the VDSL interface: RJ11 phone line connector for the MMC6005 and a BNC coax connector for the MMC6006.

## Summary of Features

---

- ❑ Very-high-bit-rate digital subscriber line (VDSL2) Line port with:
  - One RJ11 connector for the MMC6005
  - One BNC connector for the MMC6006
- ❑ 10/100/1000 Mbps Ethernet port with one RJ45 connector
- ❑ Auto-Negotiation and Auto MDI/MDI-X on Ethernet port
- ❑ Subscriber/Provider, Smart MissingLink™ (SML) features and VDSL2 profile settings may be configured by setting external DIP switches.
- ❑ Status LEDs
- ❑ 12V DC external power supply input port with locking power connector
- ❑ 12 VDC external wall-mount AC power adapter
- ❑ Installation options:
  - Desktop
  - Wall mounting
  - Rack mounting with an AT-MMCR18 chassis

## Overview

---

The MMC6000 Series VDSL Mini Media Converter can be used in multi-dwelling units (MDU), multi-tenant buildings (MTU), and in the hospitality industry, such as airports, hotels, and convention centers.

This product is designed to operate in pairs of the same model with one of the units configured as the Subscriber and the other unit configured as the Provider. In an MDU, such as a university dormitory, the Subscriber unit would be installed in each room and connected to a Provider unit through the telephone outlet, which could be located in the building wiring closet.

An MMC6000 Series unit can be installed as a desktop or wallmount device. It can also be installed in an AT-MMCR18 chassis which in turn, is mounted in an equipment rack. For installation details, refer to “Installing the Subscriber Unit” on page 39 and “Installing the Provider Unit” on page 43.

When both the Subscriber and Provider units have been installed, the media converter system topology is shown in Figure 1.

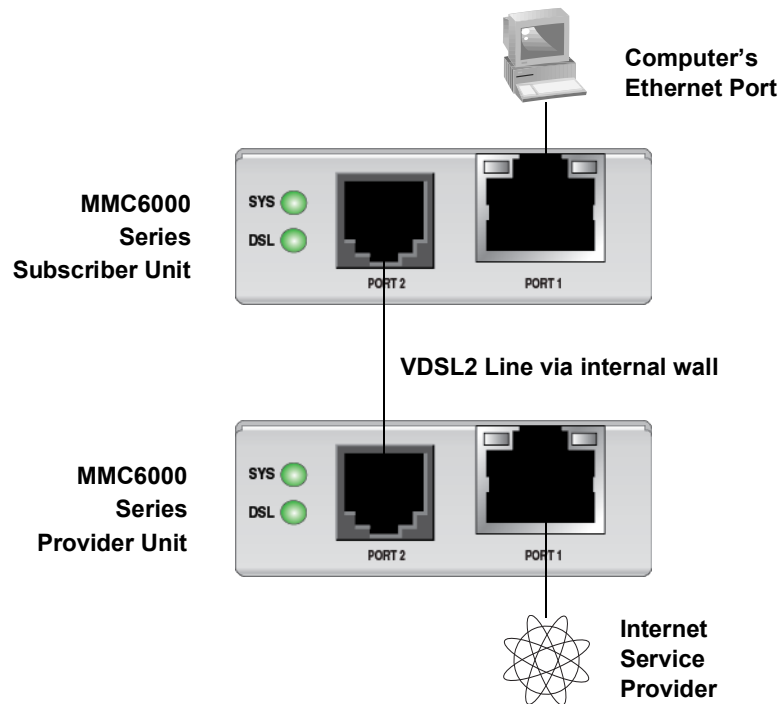

Figure 1. Media Converter System Topology

## Location of Components

Figure 2 illustrates the front panel of the MMC6005 media converter.

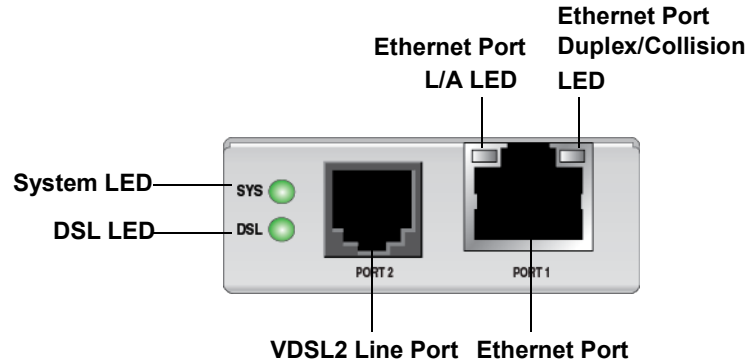

Figure 2. MMC6005 Front Panel

Figure 3 illustrates the front panel of the MMC6006 media converter.

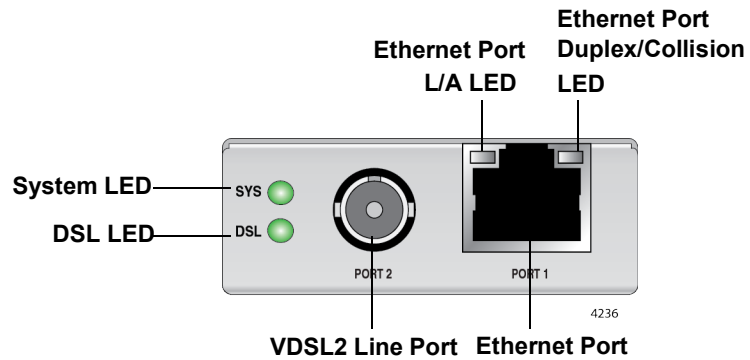

Figure 3. MMC6006 Front Panel

Figure 4 illustrates the MMC6000 Series rear panel which is used on all the models. Switches are shown in factory default positions.

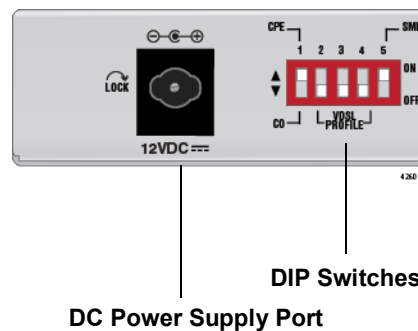

Figure 4. MMC6000 Series Rear Panel

## Feature Description

---

The following sections describe the hardware features of the MMC6000 Series media converters:

- ❑ "VDSL Line Port"
- ❑ "VDSL2 Profiles and Settings" on page 23
- ❑ "10/100/1000 Mbps Twisted Pair Ethernet Port" on page 26
- ❑ "Status LEDs" on page 27
- ❑ "DIP Switches" on page 29
- ❑ "Smart MissingLink™ (SML)" on page 31
- ❑ "DC Power Supply Input Port" on page 32
- ❑ "External AC/DC Power Adapter" on page 32

### VDSL Line Port

The VDSL Line port allows you to connect the Subscriber unit to either a telephone or coaxial cable wall outlet and the Provider unit at the wiring closet. The two units need to be within 3 km of each other in order for the port to operate properly. The port transmits data at frequencies of up to 30 MHz. This port features an RJ11 telephone connector on the MMC6005 or a BNC coax connector on the MMC6006 media converter.

Table 1 lists the pinouts and their assignments on the MMC6005 RJ11 VDSL port.

Table 1. MMC6005 RJ11 VDSL Port Pinouts

Pin	Assignment
1	Not connected
2	Not connected
3	VDSL ring
4	VDSL tip
5	Not connected
6	Not connected

## VDSL2 Profiles and Settings

The MMC6000 Series Media Converter supports all VDSL2 profiles defined by ITU-T G.993.2. When the media converter is in CO (Provider) mode, the user is allowed to select from a predetermined list of profiles (see Table 2 on page 24 and Table 3 on page 25 for details).

VDSL2 functionality is set using DIP switches 2, 3, and 4. The DIP switches are shown in Figure 6 on page 30.

---

**Note**

The VDSL2 profile is only required to be set on the Provider unit. The Subscriber unit ignores its own VDSL DIP switch settings.

---

Table 2 on page 24 lists the DIP switch settings for switches 2, 3 and 4 on the Provider unit. These settings correspond to the VDSL2 profiles and descriptions including loop lengths, and usage for various applications.

Table 3 on page 25 lists the DIP switch settings and additional information, such as corresponding bandwidth.

Table 2. VDSL2 DIP Switch Settings - Profiles, Description, Usage

DIP Switch			Profile	Description	Usage
2	3	4			
Up	Up	Up	17a	Medium loops	Medium distance applications where more data is expected to flow in a particular direction
Up	Up	Down	30a	Short loops, high data rates	Short distance applications where data is expected to flow equally in both directions
Up	Down	Up	30a	Short loops, low latency	Applications where a few milliseconds of latency is unacceptable Note: DSL link will be more susceptible to dropping and retraining due to reduced noise immunity
Up	Down	Down	30a	Short loops, high reliability	Applications where enhanced reliability of the DSL link is desired Note: maximum loop length will be reduced, compared to a link without G.inp*
Down	Up	Up	8b	Long loops	Longer distance applications where a lower maximum data throughput is acceptable
Down	Up	Down	17a	Medium loops	Medium distance applications where data is expected to flow equally in both directions
Down	Down	Up	17a	Medium loops, high reliability	Applications where enhanced reliability of DSL link is desired Note: maximum loop length will be reduced, compared to a link without G.inp
Down	Down	Down	30a	Short loops, maximum throughput	Short distances where more data is expected to flow in a particular direction

\*G.inp - ITU standard G.998.4. Provides enhanced protection against impulse noise or increases efficiency of providing Impulse Noise Protection (INP)



Table 3. VDSL2 DIP Switch Settings - Additional Information

DIP Switch			Bandwidth (MHz)	Max Loop Length*	Max Data Rate (Mbps) Downstream/Upstream**	Symmetric/Asymmetric	G.inp	Data Interleaving
2	3	4						
Up	Up	Up	17	<2.5 km (8k ft)	90/40	Asymmetric	No	Yes
Up	Up	Down	30	<1 km (35k ft)	150/150	Symmetric	No	Yes
Up	Down	Up	30	<1 km (35k ft)	180/100	Asymmetric	No	No
Up	Down	Down	30	<750 m (2.5k ft)	100/100	Symmetric	Yes	Yes
Down	Up	Up	8	<4 km (13k ft)	65/15	Asymmetric	No	Yes
Down	Up	Down	17	<2.5 km (8k ft)	75/75	Symmetric	No	Yes
Down	Down	Up	17	<2 km (6k ft)	90/40	Asymmetric	Yes	Yes
Down	Down	Down	30	<1 km (35k ft)	180/100	Asymmetric	No	Yes

\*Laboratory measurements provided for reference only. Actual data rate depends on network topology and is reduced by factors, such as interference and bridge taps.  
 \*\*Maximum data rates are attainable at very short loops. As a function of DSL technology, the maximum data rate rolls off as the length of wire increases.

Note: All settings have a 6dB noise margin.

**10/100/1000  
Mbps Twisted  
Pair Ethernet  
Port**

Each of the MMC6000 Series media converters have one twisted pair Ethernet port. The twisted pair port features RJ45 connectors with a maximum operating distance of 100 meters (328 feet). For the port pinout details, refer to “RJ45 Connector and Port Pinouts” on page 53.

**Type of Cabling**

Table 4 contains the cable specifications for the twisted-pair port.

Table 4. Twisted-Pair Port Cabling Specifications

Speed	Type of Cable
10 Mbps	Standard TIA/EIA 568-B-compliant Category 3 or better shielded or unshielded cabling with 100 ohm impedance and a frequency of 16 MHz.
100 Mbps	Standard TIA/EIA 568-A-compliant Category 5 or TIA/EIA 568-B-compliant Enhanced Category 5 (Cat 5e) shielded or unshielded cabling with 100 ohm impedance and a frequency of 100 MHz.
1000 Mbps	Standard TIA/EIA 568-A-compliant Category 5 or TIA/EIA 568-B-compliant Enhanced Category 5 (Cat 5e) shielded or unshielded cabling with 100 ohm impedance and a frequency of 100 MHz.

**Auto MDI/MDI-X**

An RJ45 twisted pair port on a 10/100/1000 Mbps Ethernet network device can have one of two possible wiring configurations: MDI or MDI-X. The RJ45 port on a PC, router, or bridge is typically wired as MDI, while the twisted pair port on a switch or hub is usually MDI-X.

The MMC6000 Series Media Converter feature automatic MDI/MDI-X. The Ethernet port automatically determines the configuration of the port on the device to which it is connected and then configures itself appropriately. For example, if a port on a media converter is connected to a port on a bridge, which is typically wired as MDI, the port on the media converter automatically configures itself as MDI-X. This feature allows you to use either a straight-through or crossover cable when connecting a device to the media converter.

**Auto-Negotiation**

The media converter Auto-Negotiates the speed and duplex mode of the Ethernet link, so that the link comes up in the highest performance configuration supported by both ends.

## Half- and Full-duplex Mode

Duplex mode refers to the way an end-node sends and receives data on the network. An end-node can operate in either half- or full-duplex mode, depending on its capabilities. An end-node that is operating in half-duplex mode can either send data or receive data, but it cannot do both at the same time. An end-node that is operating in full-duplex mode can send and receive data simultaneously. The best network performance is achieved when an end-node can operate at full-duplex, because the end-node is able to send and receive data simultaneously.

The MMC6000 Series Media Converter can operate in either half- or full-duplex mode. It can operate using Auto-Negotiation to select the duplex mode and does not support forced duplex mode. It is important to remember that the end-node connected to the ports on the media converters must be configured to operate with Auto-Negotiation too.

## Status LEDs

The MMC6000 Series media converters feature the status LEDs defined in Table 5.

Table 5. Status LEDs

LED	State	Description
SYS	Solid Green (with Heartbeat)	The media converter is receiving power.  Note: The SYS LED will flicker briefly at a regular interval. This “heartbeat” indicates that the internal system is running normally.
	Off	The media converter is not receiving power or an error is present within the media converter.

Table 5. Status LEDs (Continued)

LED	State	Description
DSL	Slow Blinking Green	VDSL is idle when blinking occurs approximately once per second.
	Fast Blinking Green	VDSL is in Training or Handshaking mode when blinking occurs approximately 3 times per second.
	Steady Green	VDSL has established connection with its link partner.
	Rapid Blinking Green	VDSL activity is occurring when blinking occurs approximately 6 times per second.
	Off	If SML is enabled, the media converter's copper port is disconnected.  Note: If SML is disabled, the DSL LED stays lit when the media converter's copper port is disconnected.
COPPER P1 L/A (L = Link; A = Activity)	Off	The port has not established a link.
	Steady Green	The port has an established link to a network device, but it is not transmitting or receiving network packets.
	Rapid Blinking Green	The port is transmitting or receiving network packets.
	Slow Blinking Green	SML is on and detects a failure on the DSL port. If slow blinking in unison with the COPPER P1 DUP/COL LED, the DSL port is training if there is a copper link present.

Table 5. Status LEDs (Continued)

LED	State	Description
COPPER P1 DUP/ COL	Off	The port has not established a link or the link is in Half-Duplex mode.
	Steady Green	The port has established a link in Full-Duplex mode.
	Rapid Blinking Green	Collisions are occurring on the port.
	Slow Blinking Green	SML is on and detects a failure on the DSL port. If slow blinking in unison with the COPPER P1 L/A LED, the DSL port is training if there is a copper link present.

**DIP Switches** Use the external DIP switches to configure the media converter as follows:

**Subscriber or Provider Configuration**

DIP switch 1 configures the media converter unit to either a Subscriber or Provider unit.

- ❑ Set the switch to Up (CPE) for a Subscriber unit
- ❑ Set the switch to Down (CO) for a Provider unit.

Refer to Figure 5 for the Subscriber/Provider switch positions.

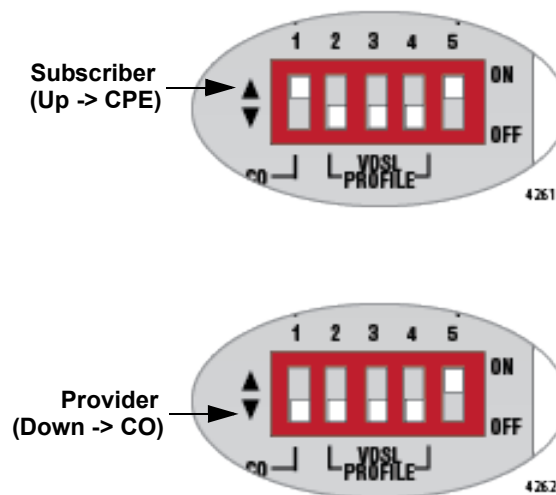

Figure 5. DIP Switch 1: Subscriber / Provider Unit Configuration

### VDSL2 Configuration

- DIP switches 2, 3, and 4 configure the media converter VDSL2 profile on the Provider unit. For the supported VDSL2 settings, refer to Table 2 on page 24 and Table 3 on page 25.

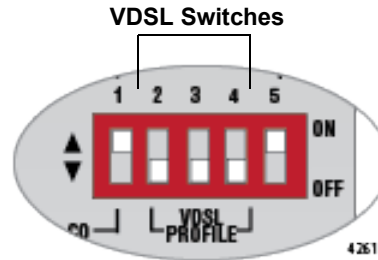

Figure 6. DIP Switches 2, 3, 4: VDSL2 Profile Configuration (Provider Only)

---

#### Note

The VDSL2 profile is only configured on the Provider unit. The Subscriber unit ignores its own VDSL DIP switch settings.

---

### Smart Missing Link (SML) Configuration

- DIP switch 5 turns Smart Missing Link (SML) on and off as follows:
  - To enable SML, set the switch to the ON (Up) position.
  - To disable SML, set the switch to the OFF (Down) position.
- See Figure 7 for the SML configuration settings

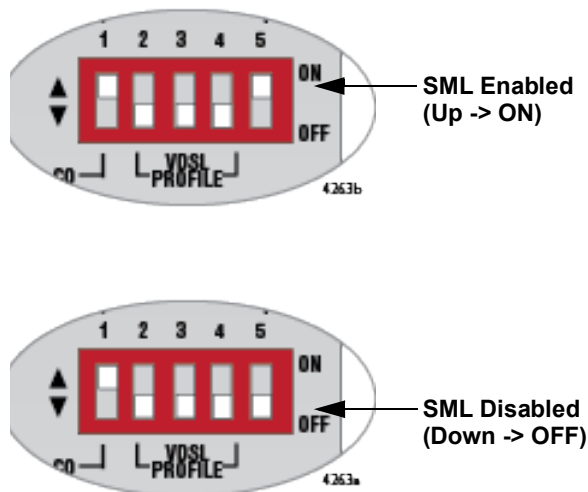

Figure 7. DIP Switch 5 - SML Configuration

## Smart MissingLink™ (SML)

### SML Overview

If an Ethernet connection to one of the media converters loses link, the Smart MissingLink™ (SML) feature allows you to determine which port still has a valid Ethernet connection and which port requires troubleshooting. The value to this type of network monitoring and fault notification is that you can quickly determine which media converter's port has failed and pinpoint the specific area where the problem is occurring.

When the first media converter in a pair detects a loss of connection on the second media converter's copper port, the second media converter's copper port's L/A LED is turned off. At the same time, the first media converter copper port's L/A LED blinks while simultaneously turning OFF its Ethernet connection to its end node. This occurs even though the first media converter's port had a valid connection before the failure occurred. The reason for this behavior is so that its end node connected to the first media converter is notified that the Ethernet connection on the second media converter is compromised, and immediate action is required to resolve the issue.

### SML Example

The following illustrations are examples of how SML behaves with two SML enabled media converters connected back-to-back (bookend mode).

Figure 8 and Figure 9 show two MMC6000 Series Media Converters and end node L/A LED behavior with SML enabled under normal conditions.

Figure 8 illustrates that all of the Ethernet links are operating properly and all of the copper L/A LEDs are on.

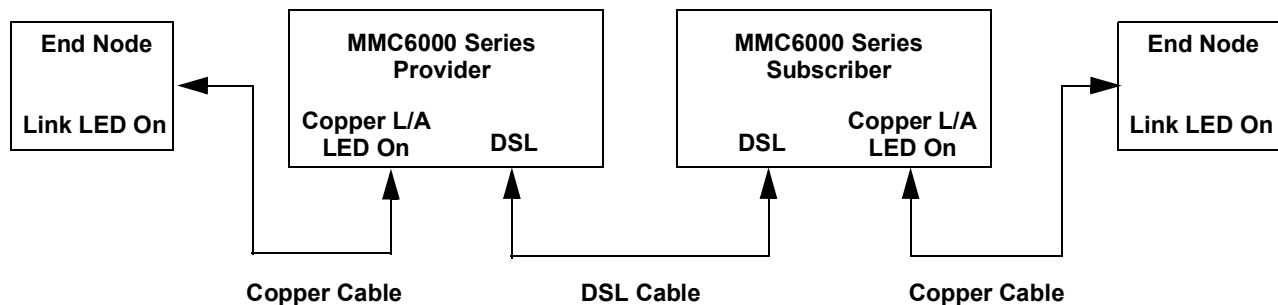

Figure 8. SML in Normal Condition with Two Media Converters

Figure 9 shows media converter and end node L/A LED behavior with SML enabled. When a copper connection is broken between the media converter on the left and its end node, the copper L/A and DSL LEDs are Off for the left media converter indicating that its Ethernet link is down. The Ethernet link on the right is disabled while its copper L/A and DSL LEDs are blinking indicating that its Ethernet link is good, but its partner 'MMC6000 Series Media Converter' link is not good.

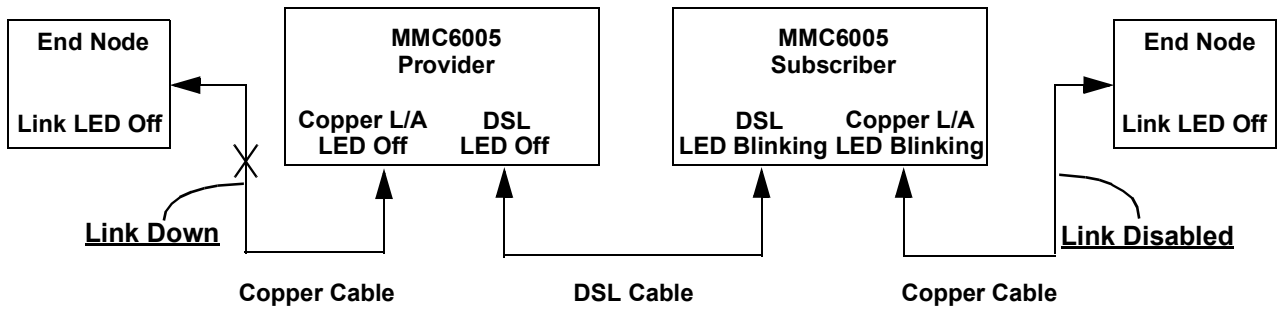

Figure 9. SML with Copper Connection to End Node Down

**DC Power Supply Input Port**

The media converter has a single DC power supply socket on the back panel. The unit does not have a power switch. To turn the media converter ON or OFF, connect or disconnect the power cord.

**External AC/DC Power Adapter**

An external AC/DC power adapter is included with the media converter for desktop or wall-mount operation. The power adapter supplies 12VDC to the media converter. Allied Telesis supplies an approved safety compliant AC power adapter specifically designed for each region in which the media converter is sold. Each type of power adapter has a regulated output of 12VDC.



## Chapter 2

# Installation

---

This chapter contains the installation procedures for the media converters. The installation process is described in the following sections:

- ❑ “Installation Safety Precautions” on page 34
- ❑ “Selecting a Site for the Media Converter” on page 36
- ❑ “Cables Not Included” on page 37
- ❑ “Unpacking the Media Converter” on page 38
- ❑ “Installing the Subscriber Unit” on page 39
- ❑ “Installing the Provider Unit” on page 43

## Installation Safety Precautions

---

Please review the following safety precautions before you begin to install the media converters.

---

### Note

The ⚡ indicates that a translation of the safety statement is available in a PDF document titled *Translated Safety Statements* on the Allied Telesis website at [www.alliedtelesis.com/support](http://www.alliedtelesis.com/support).

---



---

### Warning

Do not work on this equipment or cables during periods of lightning activity. ⚡ E2

---



---

### Caution

Power cord is used as a disconnection device. To de-energize equipment, disconnect the power cord. ⚡ E3

---



---

### Caution

Air vents must not be blocked and must have free access to the room ambient air for cooling. ⚡ E6

---



---

### Caution

All Countries: Install this product in accordance with local and national electric codes. ⚡ E8

---



---

### Caution

Operating Temperature. The MMC6005 and MMC6006 products are designed for a maximum ambient temperature of 50 degrees C. ⚡ E57

---



---

### Warning

At ambient temperatures between 55 degrees C and 65 degrees C maximum, the product may have an elevated surface temperature that may exceed the Touch Temperature Limit of 70 degrees C. Please use caution when operating the product at these ambient temperatures. ⚡ E83

---



---

**Caution**

Only use the power adapter supplied with the device. ⚡ E102

---

## Selecting a Site for the Media Converter

---

The MMC6000 Series Media Converter may be individually installed on a desk top, mounted on a wall or rack mounted.

When mounting the unit to a wall, you must use the AT-MMCWLMT Kit which is not included with the MMC6000 Series Media Converter.

It can also be installed in a rack-mounted environment by first installing the media converter in an AT-MMCR18 rack mount chassis. If you plan to install your MMC6000 Series Media Converter within a rack, refer to the AT-MMCR18 Rack Mount Chassis Installation Guide for instructions for mounting the unit within the chassis and applying power to the chassis and media converter.

Observe the following requirements when choosing a site to install your media converter on either a desktop or a wall.

- If you are installing the media converter on a table, be sure that the table is level and secure.
- The power outlet for the media converter should be located near the unit and should be easily accessible.
- The site should provide for easy access to the ports on the front of the media converter. This will make it easy for you to connect and disconnect cables, as well as view the LEDs.
- To allow proper cooling of the media converter, air flow around the unit and through its vents on the side should not be restricted.
- Do not place objects on top of the media converter.
- Do not expose the media converter to moisture or water.
- Make sure that the site is a dust-free environment.

## Cables Not Included

---

The MMC6000 Series Media Converter requires the cables described in Table 6. These cables are not included with the media converter.

Table 6. Cables

<b>Port</b>	<b>Cable</b>	<b>Connector</b>
Ethernet All MMC6000 Series models	Category 5 or better 100-ohm unshielded straight-through or crossover twisted pair cable	RJ45
VDSL Line MMC6005 models	Standard telephone cable	RJ11
VDSL Line MMC6006 models	Standard coax cable.	BNC

## Unpacking the Media Converter

---

To unpack the media converter:

1. Remove all components from the shipping package and store the packaging material in a safe location.

---



**Note**

Allied Telesis recommends that you store the packaging in case you need to return the unit for service.

---

2. Place the media converter on a level, secure surface.
3. In addition to the media converter, verify that the shipping container includes the following accessories as shown in Table 7.

Table 7. MMC6000 Series Accessory Kit

Description	Illustration
One power adapter	
Rubber Feet	

1437

## Installing the Subscriber Unit

The Subscriber unit will be used as a stand-alone device, and can be installed on a desktop, or mounted onto a wall, using wall-mounting brackets that are provided separately.

The Subscriber unit and the Provider unit must be the same model of the MMC6000 Series.

---

### Note

If you plan to install the MMC6000 Series Media Converter on a wall, you must use the AT-MMCWLMT Kit which is provided separately from the MMC6000 Series Media Converter. Refer to “AT-MMCWLMT Kit Installation” on page 55 for the wall mounting installation instructions.

---

### Using the Subscriber Unit on a Desktop

To use the Subscriber unit on a desktop, perform the following procedure:

1. Position the Subscriber unit upside down and attach the rubber feet provided to the bottom of the unit as shown in Figure 10.

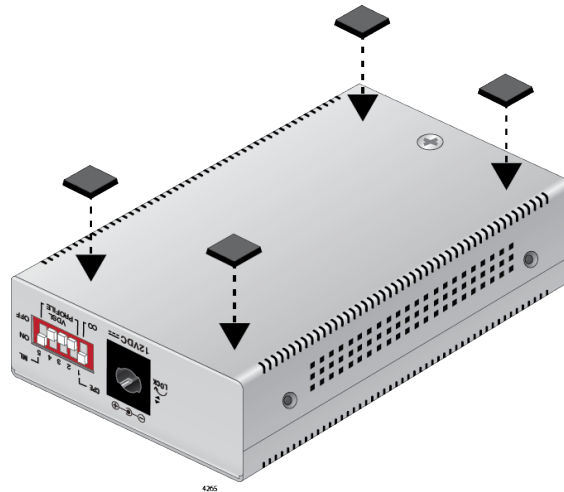

Figure 10. Subscriber Unit - Installing Feet

2. Place the Subscriber unit right side up on a flat, secure surface leaving 1 to 2 inches of space around the unit for ventilation.
3. Go to “Setting the Subscriber Unit DIP Switches” on page 40.

### Wall-Mounting the Subscriber Unit

Refer to Appendix B, “AT-MMCWLMT Kit Installation” on page 55 for instructions to wall mount the MMC6000 Series Media Converter.

## Setting the Subscriber Unit DIP Switches

1. Set DIP switch 1 to the Up (CPE) position as shown in Figure 11. This configures the media converter as a Subscriber unit.

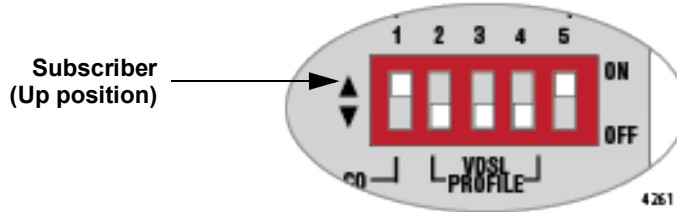

Figure 11. Subscriber Unit DIP Switch Position

2. Set DIP switch 5 to the desired SML setting:
  - The Up (ON) position enables SML.
  - The Down (OFF) position disables SML.

---

### Note

Go to “Smart Missing Link (SML) Configuration” on page 30 and “Smart MissingLink™ (SML)” on page 31 for an overview more information concerning this feature.

---

---

### Note

DIP switches 2 - 4 configure the VDSL profile and are only active on the Provider unit. The VDSL DIP switch settings on the Subscriber unit are inactive.

---

3. Go to “Cabling the Subscriber Unit”.

## Cabling the Subscriber Unit

To install the cables for the Subscriber unit, perform the following steps:

1. Connect an Ethernet cable from the RJ-45 Ethernet port to the Ethernet port on your computer, as shown in Figure 12.



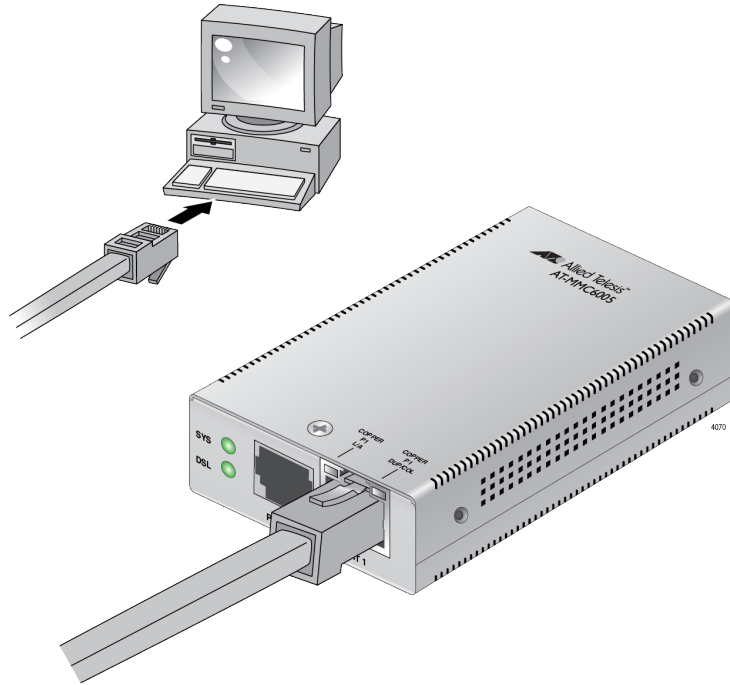

Figure 12. Subscriber Unit Ethernet Port to Computer

2. Connect the DSL port on the Subscriber unit to the VDSL wall jack or the interior VDSL line in the building with either a phone line for the MMC6005 or a coax cable for the MMC6006 as shown in Figure 13. This connection allows the Subscriber unit to communicate directly with the Provider unit.

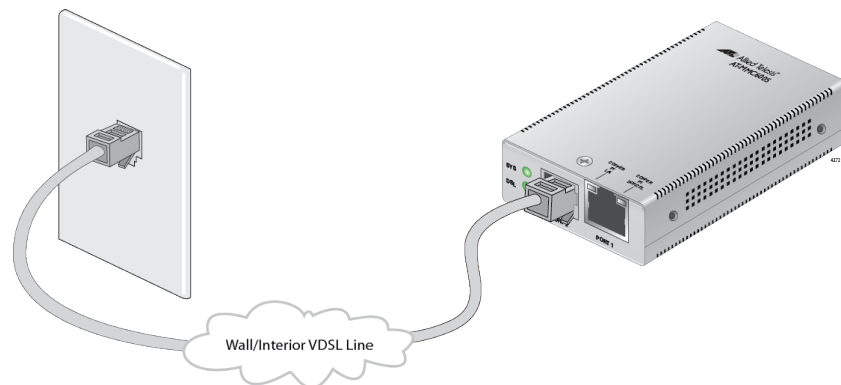

Figure 13. Subscriber Unit DSL Port to DSL Line in Building

3. Go to "Powering On the Subscriber Unit".

## Powering On the Subscriber Unit

To apply power to the Subscriber unit, perform the following:

1. Plug the DC connector of the external power adapter to the power receptacle connector labeled 12VDC on the back panel of the unit and turn the cord clockwise one-quarter turn to lock, as shown in Figure 14 on page 42.

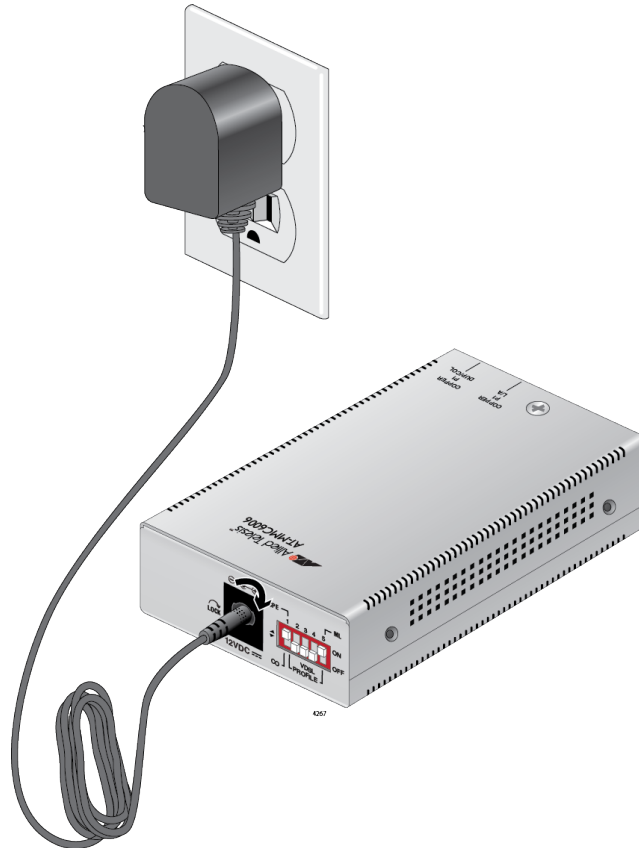

Figure 14. Subscriber Unit - Connecting 12VDC Power Adapter

2. Plug the power adapter to a power outlet. Refer to “Power Specifications” on page 52 for power requirements.
3. Verify that the SYS LED is solid green with a brief heartbeat blink. If the SYS LED is off, refer to “Troubleshooting” on page 49.

---

### Note

To power the unit OFF, disconnect the power adapter from the power outlet.

---

## Installing the Provider Unit

---

The MMC6000 Series Provider unit can be installed as a desktop device, mounted onto a wall and screws or installed into a equipment rack environment.

---

**Note**

If you plan to install the MMC6000 Series Media Converter on a wall, you must use the AT-MMCWLMT Kit which is provided separately from the MMC6000 Series Media Converter. Refer to “AT-MMCWLMT Kit Installation” on page 55 for the wall mounting installation instructions.

---

---

**Note**

If you plan to install the MMC6000 Series Media Converter in an equipment rack, the media converter must first be installed into an AT-MMCR18 chassis, which is then installed in an equipment rack. Refer to the AT-MMCR18 Chassis Installation Guide for installation instructions.

---

---

**Note**

The Subscriber unit and the Provider unit must be the same model of the MMC6000 Series.

---

### Using the Provider Unit on a Desktop

To use the Provider unit on a desktop, perform the following procedure:

1. Position the Provider unit upside down and attach the rubber feet provided to the bottom of the unit as shown in Figure 10.

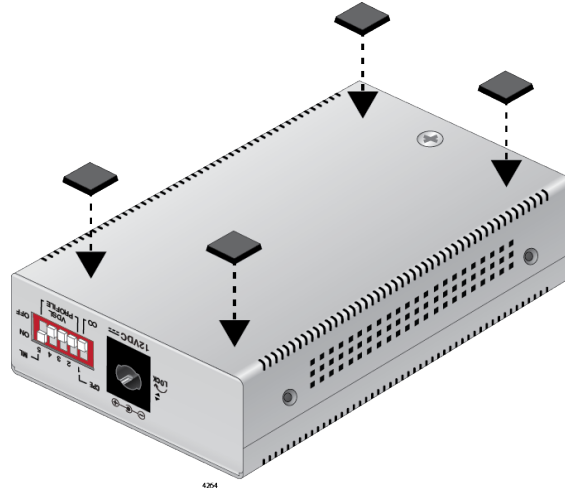

Figure 15. Provider Unit - Installing Feet

2. Place the Provider unit right side up on a flat, secure surface leaving 1 to 2 inches of space around the unit for ventilation.
3. Go to “Setting the Provider Unit DIP Switches” on page 45.

### Wall-Mounting the Provider Unit

Refer to Appendix B, “AT-MMCWLMT Kit Installation” on page 55 for instructions to wall mount the MMC6000 Series Media Converter.

### Rack Mounting the Provider Unit

To wall mount the MMC6000 Series Media Converter, it must be installed into an AT-MMCR18 chassis, which is then installed in an equipment rack.

---

**Note**

The AT-MMCR18 chassis is provided separately from the MMC6000 Series Media Converter.

---

Perform the following procedure to rack mount the MMC6000 Series Media Converter:

1. Before installing the media converter in the AT-MMCR18 chassis, go to “Setting the Provider Unit DIP Switches” on page 45 and then return to Step 2.

---

**Note**

Set the DIP switches before the media converter is installed in the AT-MMCR18 chassis because the switches are hidden afterward.

---

## Setting the Provider Unit DIP Switches

2. Refer to the AT-MMCR18 Chassis Installation Guide for installation instructions.
3. Go to “Cabling the Provider Unit” on page 46.
1. Set DIP switch 1 to the Down (CO) position as shown in Figure 16. This configures the media converter as a Provider unit.

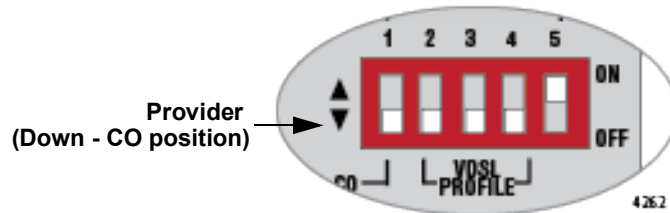

Figure 16. Provider Unit DIP Switch Position

---

### Note

DIP switches 2 - 4 configure the VDSL profile and are active only on the Provider unit. It is important to configure the Provider unit VDSL profile in the next step - Step 2. The Subscriber unit ignores its own VDSL DIP switch settings.

---

2. Set DIP switches 2, 3, and 4 to the desired VDSL2 profile. Refer to Table 2 on page 24 and Table 3 on page 25 for the profile definitions.

---

### Note

Go to “VDSL2 Configuration” on page 30 for more information.

---

3. Set DIP switch 5 to the desired SML setting: the Up (ON) position enables SML; the Down (OFF) position disables SML.

---

### Note

Go to “Smart Missing Link (SML) Configuration” on page 30 and “Smart MissingLink™ (SML)” on page 31 for an overview more information concerning this feature.

---

4. If you are mounting your media converter on a desktop or a wall, go to “Cabling the Provider Unit” on page 46.

If you are installing your media converter in an AT-MMCR18 chassis to be rack mounted, go to step 2 of “Rack Mounting the Provider Unit” on page 44.

## Cabling the Provider Unit

To cable the Provider unit, perform the following steps:

1. Connect an Ethernet cable from the Provider Ethernet port to the Service Provider box in your wiring closet, as shown in Figure 17.

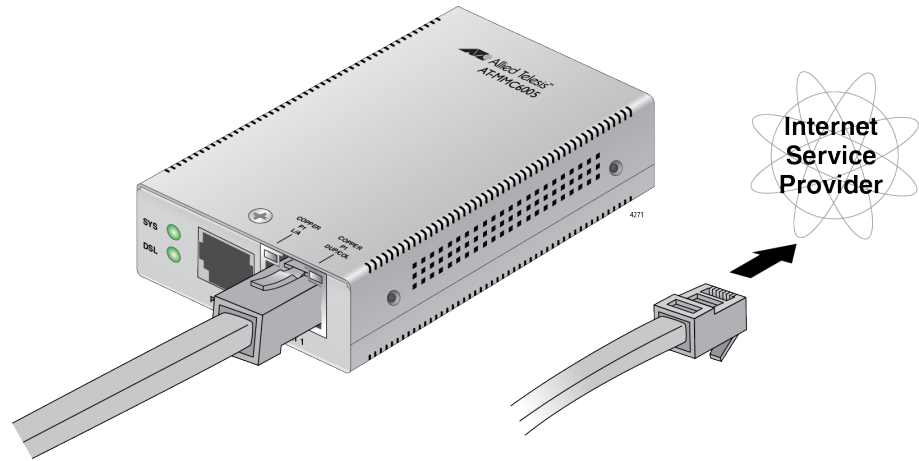

Figure 17. Provider Unit Ethernet Port to Internet Service Provider

2. Connect the VDSL Line port on the Provider unit to the VDSL wall jack or the building VDSL line in the building with either a phone line for the MMC6005 or a coax cable for the MMC6006 as shown in Figure 18. This connection allows the Provider unit to communicate directly with the Subscriber unit.

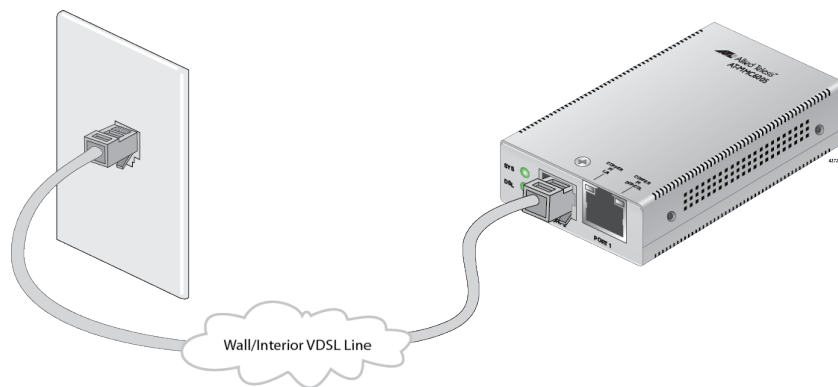

Figure 18. Provider Unit to Wall Plug or Interior VDSL Line in Building

3. Go to "Powering On the Provider Unit" on page 47.

## Powering On the Provider Unit

To apply power to the Provider unit, perform the following:

1. Plug the DC of the external power adapter to the power receptacle connector labeled 12VDC on the back panel of the unit and turn the cord clockwise one-quarter turn to lock, as shown in Figure 14 on page 42.

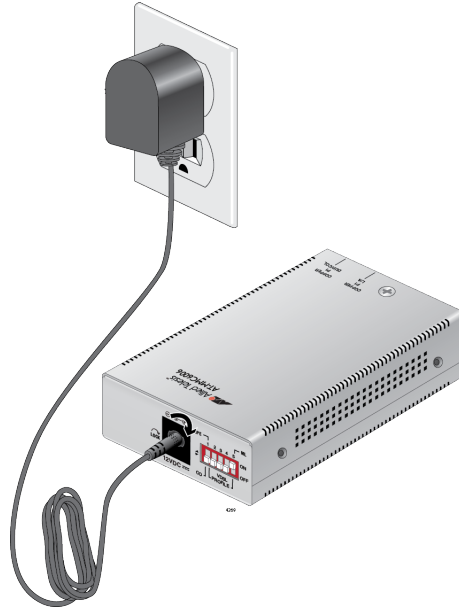

Figure 19. Provider Unit - Connecting 12VDC Power Adapter

2. Plug the power adapter to a power outlet. Refer to “Power Specifications” on page 52 for power requirements.
3. Verify that the SYS LED is solid green with a brief heartbeat blink. If the SYS LED is off, refer to “Troubleshooting” on page 49.

---

### Note

To power the unit OFF, disconnect the power adapter from the power outlet

---





## Chapter 3

# Troubleshooting

---

This chapter contains information on how to troubleshoot the MMC6000 Series media converters in the event a problem occurs.

---

### Note

For further assistance, please contact Allied Telesis Technical MMC6000 Series Installation GuideSupport at [www.alliedtelesis.com/support](http://www.alliedtelesis.com/support).

---

**Problem 1:** The SYS LED on the media converter is off.

**Solutions:** The unit is not receiving power. Try the following:

- ❑ Verify that the power cord is securely connected to the power source and to the DC connector on the back panel of the media converter.
- ❑ Verify that the power outlet has power by connecting another device to it.
- ❑ Try using another power adapter of the same type that came with your media converter.
- ❑ Verify that the voltage from the power source is within the required levels for your region.

**Solution:** An internal component on the unit is damaged or not working properly. Try power cycling the unit. If power cycling does not clear the fault, return the unit to Allied Telesis.

**Problem 2:** The twisted-pair port on the media converter is connected to an end node, but the port's COPPER P1 L/A LED is off.

**Solutions:** The port is unable to establish a link to an end node. Try the following:

- ❑ Verify that the end node connected to the twisted-pair port is

powered on and is operating properly.

- ❑ Verify that the twisted-pair cable is securely connected to the port on the media converter channel and to the port on the remote end-node.
- ❑ Verify that the port is connected to the correct twisted-pair cable. This is to eliminate the possibility that the port is connected to the wrong end-node, such as a powered-off device.
- ❑ Try connecting another end node to the twisted-pair port with a different cable. If the twisted-pair port is able to establish a link, then the problem is with the cable or the other end-node.
- ❑ Verify that the twisted-pair cable does not exceed 100 meters (328 feet).
- ❑ Verify that the end node connected to the media converter is set to Auto-Negotiate.
- ❑ Verify that you are using the appropriate category of twisted-pair cable: Category 3 or better for 10 Mbps operation and Category 5 and Category 5E for 100 and 1000 Mbps operation.

---

**Note**

A 1000Base connection may require 5 to 10 seconds to establish a link.

---

**Problem 3:** Network performance between the twisted-pair port on the media converter and an end node is slow.

**Solution:** There might be a duplex mode mismatch between the port and the end node. Check the duplex LED on the right side of the RJ45 connector for the duplex status. This occurs when the MMC6000 Series Media Converter which is configured for Auto Negotiation is connected to a device with a fixed duplex mode. If this is the cause of the problem, set the end node to Auto-Negotiate.

**Problem 4:** The DSL LED on the media converter is off.

**Solutions:** The DSL subsystem has stopped responding.

- ❑ Power cycle the media converter.
- ❑ Check the copper connection. The DSL LED will turn off if the local unit has SML enabled, and the copper connection is lost.

## Appendix A

# Technical Specifications

---

Below are the technical specifications for the media converters. The specification categories are as follows:

- “Physical Specifications”
- “Environmental Specifications”
- “Power Specifications” on page 52
- “Safety and Electromagnetic Emissions Certifications” on page 52
- “RJ45 Connector and Port Pinouts” on page 53

## Physical Specifications

---

Table 8. Physical Specifications

Dimensions W x D x H	50.8 mm x 99.1 mm x 20.3 mm (2.0 in x 3.9 in x 0.8 in)
Weight	0.2 kg (0.4 lb)

## Environmental Specifications

---

Table 9 lists environmental specifications for the MMC6000 Series Media Converter.

Table 9. Environmental Specifications

Operating Temperature	0° C to 50° C (32° F to 122° F)
Storage Temperature	-30° C to 70° C (-22° F to 158° F)
Operating Humidity	5% to 90% non-condensing
Storage Humidity	5% to 95% non-condensing
Operating Altitude Range	Up to 3,000 m (9,843 ft)

## Power Specifications

---

The following specifications apply to the DC power connector on the media converter.

Table 10. Power Specifications

Input supply voltage	12 VDC
Input current (typical)	200 mA
Input current (maximum)	500 mA

## Safety and Electromagnetic Emissions Certifications

---

Table 11. Safety and Electromagnetic Emissions Certifications

Safety	UL60950-1, EN60950-1
Emissions (EMI)	FCC Class B, CISPR 22 Class B, EN55032 Class B, C-TICK, VCCI Class B
Immunity	EN55024, EN61000-3-2, EN61000-3-3
Environmental Compliance	EU-RoHS compliant, WEEE China RoHS compliant

## RJ45 Connector and Port Pinouts

Figure 20 illustrates the pin layout for the RJ45 connector and port.

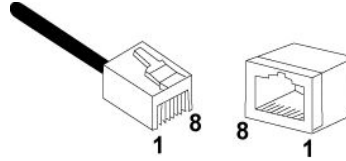

Figure 20. RJ45 Connector and Port Pin Layout

Table 12 lists the pin signals when a port is operating in the MDI configuration at 10 or 100 Mbps.

Table 12. MDI Pin Signals (10 or 100 Mbps)

Pin	Signal
1	TX+
2	TX-
3	RX+
6	RX-

Table 13 lists the pin signals when a port is operating in the MDI-X configuration at 10 or 100 Mbps.

Table 13. MDI-X Pin Signals (10 or 100 Mbps)

Pin	Signal
1	RX+
2	RX-
3	TX+
6	TX-

Table 14 lists the pin signals when a port is operating at 1000 Mbps.

Table 14. Pin Signals (1000 Mbps)

<b>Pin</b>	<b>Pair</b>	<b>Signal Name</b>
1	1	TX+_D1
2	1	TX-_D1
3	2	RX+_D2
4	3	BI+_D3
5	3	BI-_D5
6	2	RX-_D2
7	4	BI+_D4
8	4	BI-_D4



## Appendix B

# AT-MMCWLMT Kit Installation

Before installing an MMC media converter on a wall, you must have an AT-MMCWLMT Kit that is provided separately.

1. Verify that the AT-MMCWLMT Kit contains the items shown in Table 15.

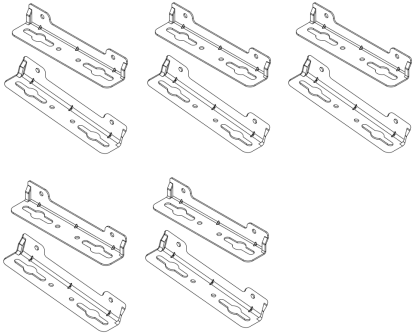
Table 15 AT-MMCR WLMT Kit Contents

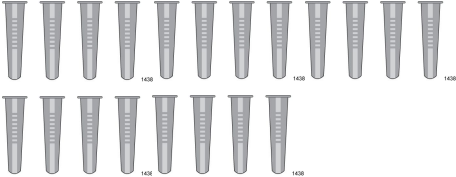
Description	Illustration
5 Sets of Wall Mounting Brackets	
20 Bracket Screws	
20 Self-Tapping Screws	
20 Plastic Anchors	

2. Select a wall location for the unit.
3. Place the unit on a table.

4. Orient the brackets against the sides of the unit, as shown in Figure 21, and secure them to the unit with the four of the brackets screws included.

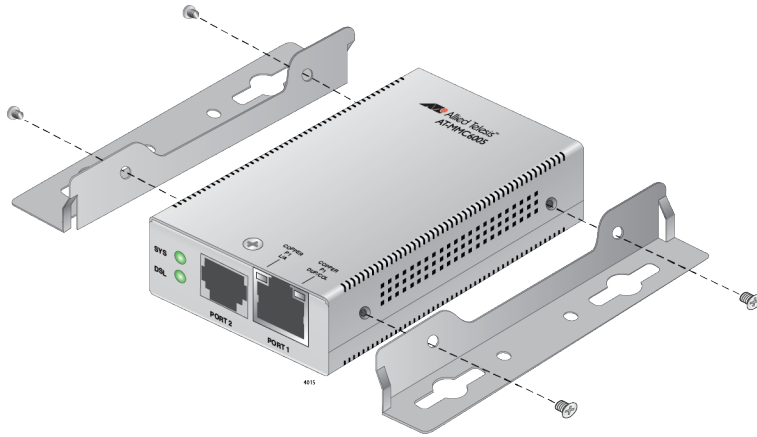

Figure 21. Attaching the Brackets to the Media Converter

5. Print out the template in Figure 22.

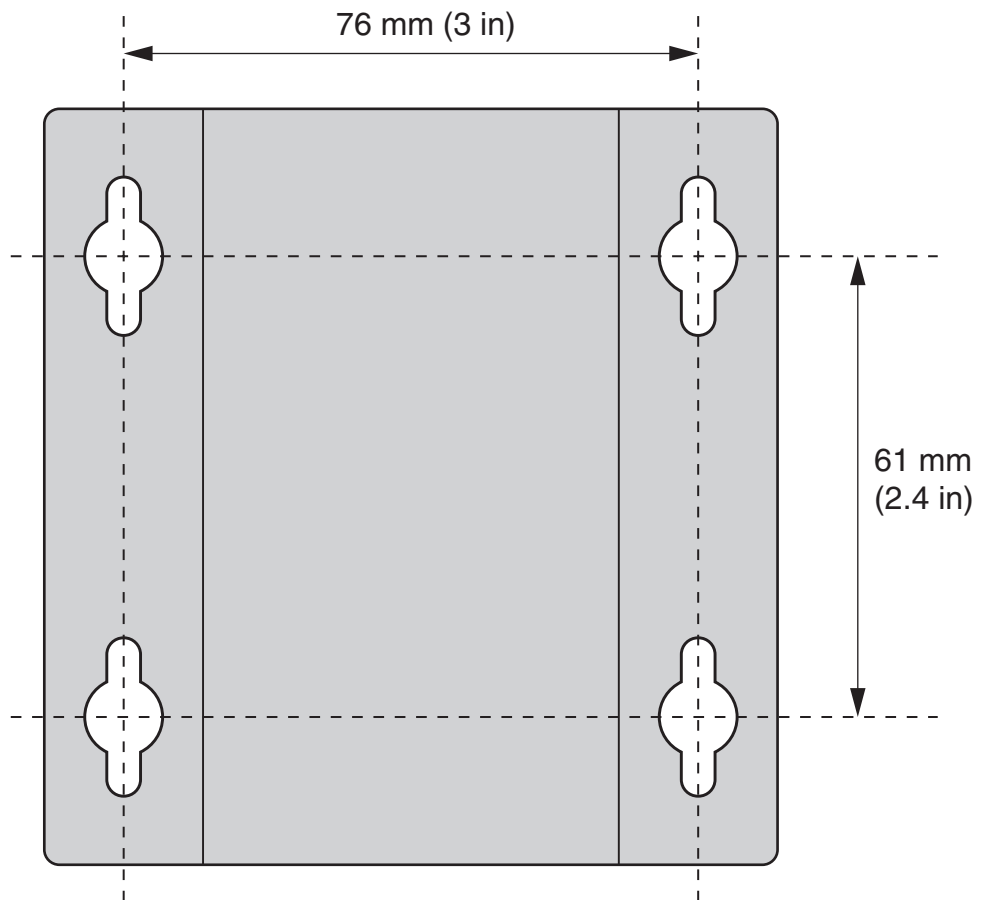

Figure 22. Wall-mount Template



6. Attach the template to the wall with tape where you want to install your media converter.
7. Pre-drill four 3/16" (5mm) holes at the locations on the templates as shown in Figure 23.

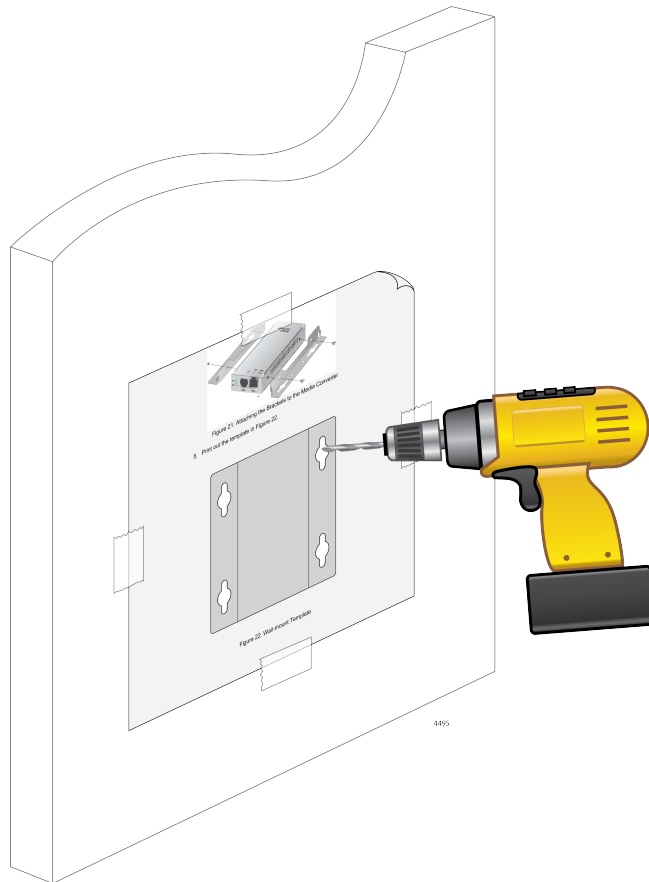

Figure 23. Placing the Template on the Wall

8. Remove the template from the wall.
9. Install four plastic anchors included with AT-MMCWLMT Kit into the wall, at the holes you drilled in the previous step.
10. Secure the media converter unit to the wall using four wall-mounting screws. See Figure 24 on page 58.

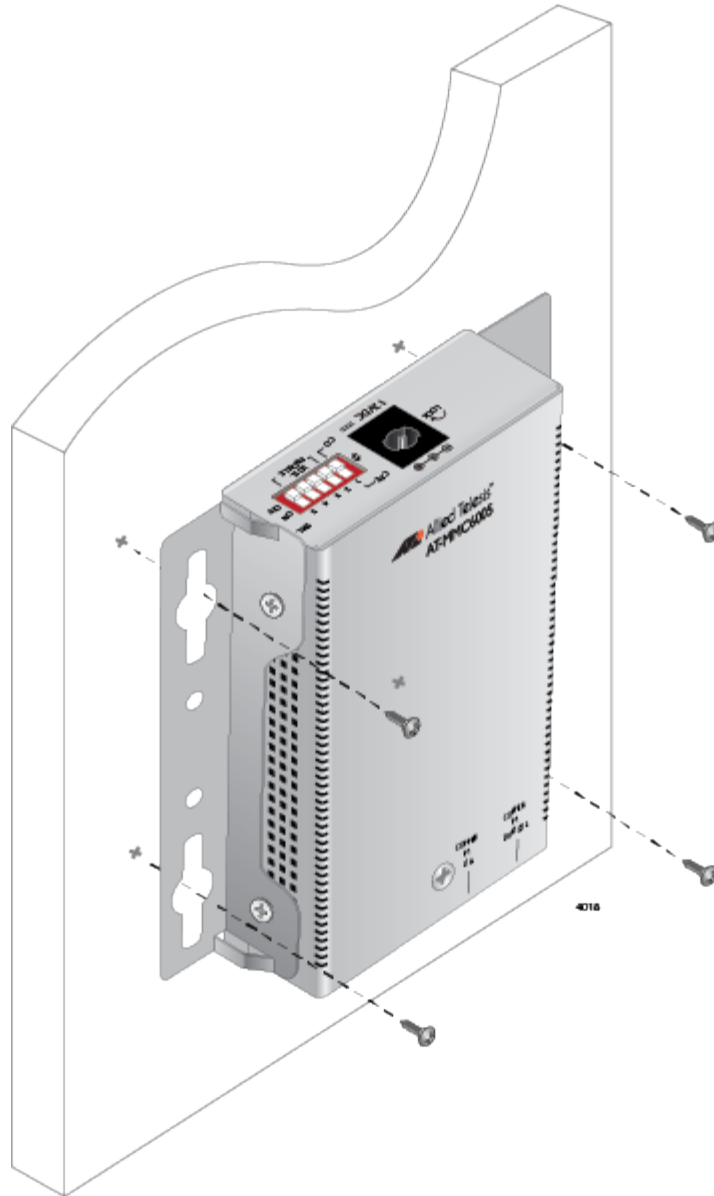

Figure 24. Securing the Media Converter to the Wall