

AT-MMC1000/SP

Mini Switching Media Converters

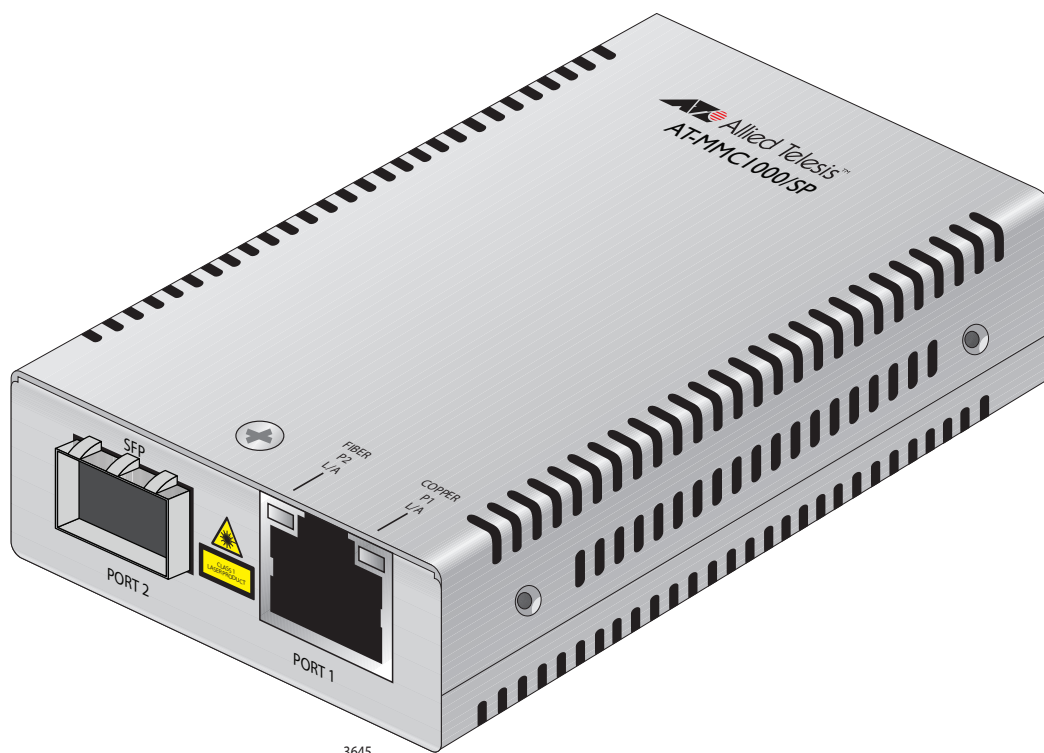

Installation Guide

Copyright © 2021 Allied Telesis, Inc.

All rights reserved. No part of this publication may be reproduced without prior written permission from Allied Telesis, Inc.

Allied Telesis and the Allied Telesis logo are trademarks of Allied Telesis, Incorporated. All other product names, company names, logos or other designations mentioned herein are trademarks or registered trademarks of their respective owners.

Allied Telesis, Inc. reserves the right to make changes in specifications and other information contained in this document without prior written notice. The information provided herein is subject to change without notice. In no event shall Allied Telesis, Inc. be liable for any incidental, special, indirect, or consequential damages whatsoever, including but not limited to lost profits, arising out of or related to this manual or the information contained herein, even if Allied Telesis, Inc. has been advised of, known, or should have known, the possibility of such damages.

Electrical Safety and Emissions Standards

This section contains the following:

- “US Federal Communications Commission”
- “Industry Canada”
- “Electrical Safety Standards” on page 4
- “Translated Safety Statements” on page 4

US Federal Communications Commission

Radiated Energy

Note

This equipment has been tested and found to comply with the limits for a Class A digital device pursuant to Part 15 of FCC Rules. These limits are designed to provide reasonable protection against harmful interference when the equipment is operated in a commercial environment. This equipment generates, uses, and can radiate radio frequency energy and, if not installed and used in accordance with this instruction manual, may cause harmful interference to radio communications. Operation of this equipment in a residential area is likely to cause harmful interference in which case the user will be required to correct the interference at his own expense.

Note

Modifications or changes not expressly approved of by the manufacturer or the FCC, can void your right to operate this equipment.

Industry Canada

Radiated Energy

This Class A digital apparatus complies with Canadian ICES-003.

Cet appareil numérique de la classe A est conforme à la norme NMB-003 du Canada.

Electrical Safety Standards

Safety UL62368-1 (CUL_{US}), CE, IEC60950-1, IEC/EN62368-1, EN62368-1, AS/NZS62368-1

Electro Magnetic Interference (EMI) FCC part15 Subpart B/Class A
ICES-003:2016, Issue6 Class A
EN55032:2012/AC:2013 Class A
CISPR 32:2012
VCCI Class A
RCM AS/NZS CISPR 32:2013



Warning

In a domestic environment this product may cause radio interference in which case the user may be required to take adequate measures. ⚡ E84

Electro Magnetic Susceptibility (EMS) EN61000-4-2:2009
EN61000-4-3:2006 + A1:2008 + A2:2010
EN61000-4-4:2012
EN61000-4-5:2014
EN61000-4-6:2014
EN61000-4-8:2010
EN61000-4-11:2004
EN61000-3-2:2014
EN61000-3-3:2013

Translated Safety Statements

Important: The ⚡ indicates that a translation of the safety statement is available in a PDF document titled *Translated Safety Statements* on the Allied Telesis website at www.alliedtelesis.com/support.

Contents

Preface	11
Symbol Conventions	12
Contacting Allied Telesis	13
Chapter 1: Overview	15
Introduction	16
Features	17
Twisted-Pair Port	18
Auto MDI/MDI-X	18
Auto-Negotiation or 100 Mbps Full-Duplex Mode.....	18
External AC/DC Power Adapter	19
Supported SFP Modules	19
LEDs	21
Smart MissingLink™ (SML)	23
Guidelines.....	23
SML Example Scenarios	23
Enabling SML.....	25
Reset the Media Converter	26
Chapter 2: Installation	27
Reviewing Safety Precautions	28
Selecting a Site for the Media Converter	30
Planning the Installation	31
Unpacking the Media Converter.....	33
Installing the Media Converter	34
Installing the Media Converter on a Desktop.....	34
Installing the SFP Transceiver	35
Powering On and Cabling the Media Converter.....	37
Cabling Guidelines	37
Applying Power and Connecting the Network Cables	37
Chapter 3: Troubleshooting	39
Appendix A: Technical Specifications	43
Physical Specifications.....	43
Environmental Specifications	43
Power Specifications.....	44
RJ45 Connector and Port Pinouts.....	44
Appendix B: AT-MMCWLMT Kit Installation	47

Figures

Figure 1: AT-MMC1000/SP Media Converter.....	16
Figure 2: AT-MMC1000/SP Front Panel.....	16
Figure 3: Media Converter Back Panel.....	17
Figure 4: PWR and SYS LEDs.....	21
Figure 5: Port LEDs.....	21
Figure 6: SML in Normal Condition with Two Media Converters.....	24
Figure 7: SML with Copper Connection to End Node Down.....	24
Figure 8: SML with Fiber Connection Between Media Converters Down.....	24
Figure 9: AT-MMC1000/SP Media Converter Rear Panel DIP Switches.....	25
Figure 10: Power Adapter in the Shipping Package.....	33
Figure 11: Inserting the SFP.....	36
Figure 12: Positioning the SFP Handle in the Upright Position.....	36
Figure 13: Connecting 12VDC Powered Unit.....	37
Figure 14: RJ45 Connector and Port Pin Layout.....	44
Figure 15: Attaching the Brackets to the Media Converter.....	48
Figure 16: Wall-mount Template.....	48
Figure 17: Placing the Template on the Wall.....	49
Figure 18: Securing the Media Converter to the Wall.....	50

Tables

Table 1. Media Converter LED Functional Descriptions	22
Table 2. Twisted-Pair Port Cabling Specifications	31
Table 3. Copper Connection Speed/Duplex Settings and Resulting Speed	32
Table 4. Physical Specifications	43
Table 5. Environmental Specifications	43
Table 6. Power Specifications	44
Table 7. MDI Pin Signals (10 or 100 Mbps)	44
Table 8. MDI-X Pin Signals (10 or 100 Mbps)	45
Table 9. Pin Signals (1000 Mbps)	45
Table 10. AT-MMCR WLMT Kit Contents	47

Preface

This preface contains the following sections:

- “Symbol Conventions” on page 12
- “Contacting Allied Telesis” on page 13

This guide is the installation instructions for the AT-MMC1000/SP Mini Switching Media Converter.

Symbol Conventions

This document uses the following conventions:

Note

Notes provide additional information.



Caution

Cautions inform you that performing or omitting a specific action may result in equipment damage or loss of data.



Warning

Warnings inform you that performing or omitting a specific action may result in bodily injury.



Warning

Laser warnings inform you that an eye and skin hazard exists due to the presence of a Class 1 laser device.

Contacting Allied Telesis

If you need assistance with this product, you may contact Allied Telesis technical support by going to the Services & Support section of the Allied Telesis web site at **www.alliedtelesis.com/support**. You can find links for the following services on this page:

- ❑ Helpdesk (Support Portal) - Log onto Allied Telesis interactive support center to search for answers to your questions in our knowledge database, check support tickets, learn about Return Merchandise Authorizations (RMAs), and contact Allied Telesis technical experts.
- ❑ Software Downloads - Download the latest software releases for your product.
- ❑ Licensing - Register and obtain your License key to activate your product.
- ❑ Product Documents - View the most recent installation guides, user guides, software release notes, white papers and data sheets for your product.
- ❑ Warranty - View a list of products to see if Allied Telesis warranty applies to the product you purchased and register your warranty.
- ❑ Allied Telesis Helpdesk - Contact a support representative.

To contact a sales representative or find Allied Telesis office locations, go to **www.alliedtelesis.com/contact**.

Chapter 1

Overview

This chapter contains the following sections:

- “Introduction” on page 16
- “LEDs” on page 21
- “Smart MissingLink™ (SML)” on page 23
- “Reset the Media Converter” on page 26

Introduction

The AT-MMC1000/SP Mini Switching Media Converter as shown in Figure 1 is equipped with to a twisted pair port and SFP slot to allow enterprises to connect copper networks to fiber networks and extend the distance of these networks by interconnecting LAN devices physically separated by large distances.



Figure 1. AT-MMC1000/SP Media Converter

Figure 2 illustrates the front panel of the media converter.

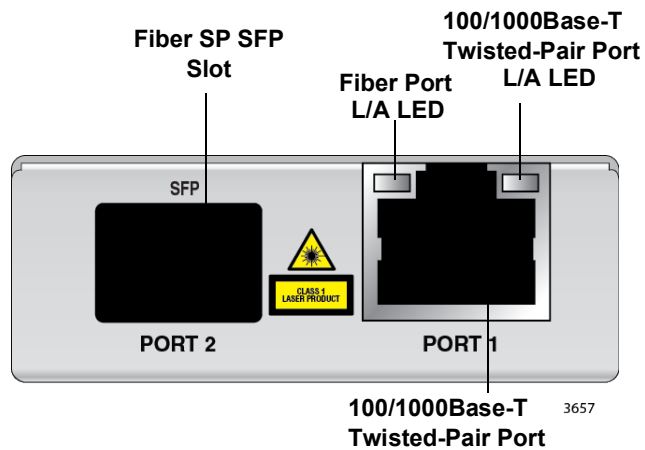

Figure 2. AT-MMC1000/SP Front Panel

Figure 3 illustrates the media converter back panel.

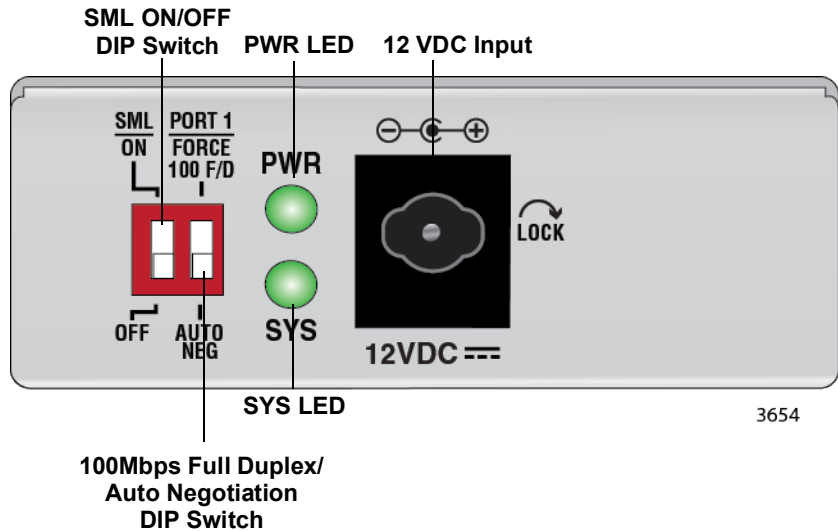

Figure 3. Media Converter Back Panel

Features Here are the key features of the AT-MMC1000/SP media converter:

- Space-saving small device
- Cost-effective method for integrating from 100M/1GBase-T to 100M/1GBase-TX environment
- Smart MissingLink™ (SML)
- DIP switch for activating the SML feature
- DIP switch for 100 Mbps full-duplex mode or Auto-Negotiation
- Auto Negotiation and Auto MDI/MDI-X on the twisted-pair port
- Wall mount
- Equipment rack mount
- Support for Jumbo frames up to 10kB
- LEDs for unit and port status
- 12 VDC external wall-mount AC power adapter
- 100Mbps and 1Gbps SFP modules are supported. For a list of supported transceivers, see “Supported SFP Modules” on page 19.

Note

You must purchase the SFP transceiver separately.

Twisted-Pair Port

Here are the basic features of the twisted-pair (copper) port:

- IEEE 802.3u Auto-Negotiation compliant
- Auto MDI/MDI-X
- 100 meters (328 feet) maximum operating distance
- RJ45 connector

The twisted-pair port features an eight-pin RJ45 connector that uses four pins at 10 or 100 Mbps and all eight pins at 1000 Mbps. For the port pinouts, see “RJ45 Connector and Port Pinouts” on page 44.

Note

For twisted-pair port cabling specifications, refer to Table 2 on page 31.

Auto MDI/MDI-X

An RJ45 twisted-pair port on a 100 Mbps Ethernet network device can have one of two possible wiring configurations: MDI or MDI-X. The RJ45 port on a PC, router, or bridge is typically wired as MDI, while the twisted-pair port on a switch or hub is usually MDI-X.

The media converter features Auto MDI/MDI-X. The twisted-pair port automatically determines the configuration of the port on the device to which it is connected and then configures itself appropriately.

For example, if a port on a media converter is connected to a port on a bridge, which is typically wired as MDI, the port on the media converter automatically configures itself as MDI-X.

This feature allows you to use a straight-through cable when connecting any type of device to the media converter, regardless of the wiring configuration of the port on the device.

Auto-Negotiation or 100 Mbps Full-Duplex Mode

You can set the twisted-pair port to 100 Mbps full-duplex mode or Auto-Negotiation mode using the PORT 1 (right) DIP switch on the rear panel. See Figure 9 on page 25.

- When this DIP switch is in the FORCE 100 F/D (up) position, the twisted-pair port is forced to 100 Mbps full-duplex mode, and Auto Negotiation is disabled.
- When in the AUTO NEG (down) position, the twisted-pair port operates in Auto-Negotiation mode.

Note

100 Mbps full-duplex mode should not be used unless absolutely necessary because forcing 100 Mbps full-duplex in most applications is likely to cause a duplex mismatch, in turn, causing poor network performance. 100 Mbps full-duplex mode should only be used when the link partner is already forced to 100 Mbps full-duplex operation, and Auto Negotiation is disabled on the link partner. In this specific case, using Auto Negotiation on the media converter would result in a duplex mismatch.

**External AC/DC
Power Adapter**

An external AC/DC power adapter is included with the media converter for standalone operation. The power adapter supplies 12 VDC to the media converter. Allied Telesis supplies a UL approved safety compliant AC power adapter for the 120 and 240 VAC versions with a regulated output of 12 VDC. The power required for the media converter is 12 VDC, 200 mA and the power adapter complies with LPS/PS2 requirements.

Note

The media converter power receptacle has a twist-and-lock barrel which is locked by turning the power cord clockwise one-quarter turn.

**Supported SFP
Modules**

Here is a list of supported SFP modules for the media converter:

- AT-SPSX
- AT-SPSX2
- AT-SPLX10a
- AT-SPLX40
- AT-SPLX80
- AT-SPZX120/I
- AT-SPBDM-A
- AT-SPBDM-B
- AT-SPBD10-13
- AT-SPBD10-14
- AT-SPBD40-13/I
- AT-SPBD40-14/I
- AT-SPBD80-A
- AT-SPBD80-B
- AT-SPFX/2
- AT-SPFX/15

- AT-SPFXBD-LC-13
- AT-SPFXBD-LC-15
- AT-SPFX/2(V2)
- AT-SPFX30/I
- AT-SPBD20LC/I-13
- AT-SPBD20LC/I-14

LEDs

Figure 4 shows the PWR and SYS LEDs on the back panel.

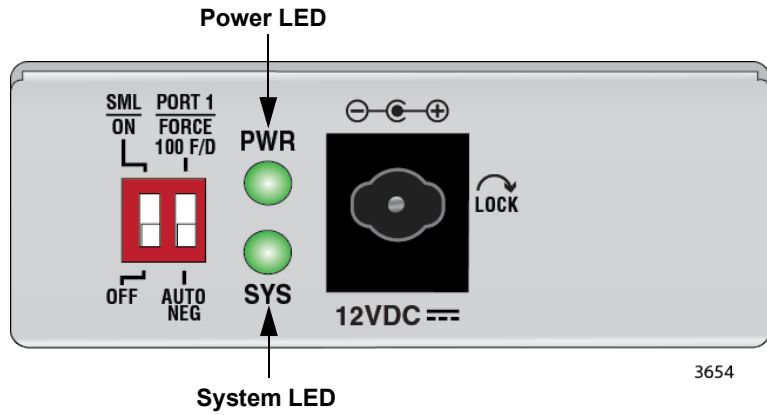

Figure 4. PWR and SYS LEDs

Figure 5 shows the port LEDs on the front panel.

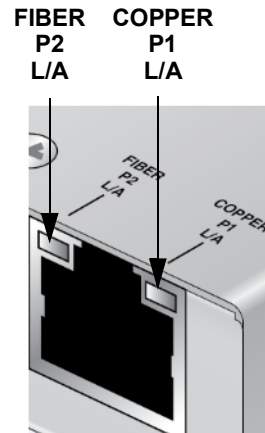

Figure 5. Port LEDs

Table 1 on page 22 describes the media converter's LEDs.

Table 1. Media Converter LED Functional Descriptions

LED	State	Description
PWR	Off	The media converter is not receiving power.
	Steady Green	The media converter is receiving power.
SYS	Off	The media converter is not operational and will not pass traffic.
	Solid Green (with Heartbeat)	The media converter is operational. Note The SYS LED flickers briefly at a regular interval. This “heartbeat” indicates that the internal system is running normally.
	Slow Blinking Green	An error is present on the media converter. The error can occur when: <ul style="list-style-type: none"> ■ An SFP module is <i>not</i> installed. ■ An installed SFP module is <i>not</i> supported. See “Supported SFP Modules” on page 19.
COPPER P1 L/A (L = Link; A = Activity)	Off	The port has not established a link.
	Steady Green	The port has an established link to a network device, but it is not transmitting or receiving network packets.
	Rapid Blinking Green	The port is transmitting or receiving network packets.
	Slow Blinking Green	SML is on and detects a failure on the fiber port.
FIBER P2 L/A (L = Link; A = Activity)	Off	The port has not established a link.
	Steady Green	The port has an established link to a network device, but it is not transmitting or receiving network packets.
	Rapid Blinking Green	The port is transmitting or receiving network packets.
	Slow Blinking Green	SML is on and detects a failure on the copper port or the remote fiber port when operating in a back-to-back configuration with another AT-MMC1000/SP or an AT-MMC2000/SP media converter. See Figure 7 on page 24.

Smart MissingLink™ (SML)

If one of the Ethernet connections to the media converter loses link, the Smart MissingLink™ (SML) feature allows you to determine which port still has a valid connection and which port requires troubleshooting. The value to this type of network monitoring and fault notification is that you can quickly determine which media converter port has failed and troubleshoot the specific area where the problem is occurring.

When the media converter detects a loss of connection on one of the ports, the port's L/A LED is turned off. At the same time, the media converter causes the opposite port's L/A LED to blink while simultaneously turning OFF that port's Ethernet connection to its end node. This occurs even though the properly operating port had a valid connection before the failure occurred: The reason for this is so that its end node is notified that the data path has been compromised, and immediate action is required.

For example, if the network connection to the media converter's twisted-pair port fails (as shown in Figure 7 on page 24), the FIBER P2 L/A LED blinks slowly while the fiber port's link is turned OFF. The COPPER P2 L/A LED is turned OFF, indicating a failed connection on the twisted-pair port.

If the failure had started with the fiber-optic cabling (as shown in Figure 8 on page 24), then the COPPER P2 L/A LED would blink slowly, and the FIBER P2 L/A LED would turn OFF.

Guidelines Here are a list of guidelines for enabling SML on media converters:

- SML is supported when two media converters are connected back-to-back.
- The AT-MMC1000/SP media converter must be connected with another AT-MMC1000/SP media converter or an AT-MMC2000/SP media converter.
- The SFP modules installed on the two media converters must be the same model.
- You must disable SML on the AT-MMC1000/SP media converter if the other media converter is not an AT-MMC1000/SP or AT-MMC2000/SP media converter.

SML Example Scenarios Following are example scenarios with two SML enabled media converters connected back-to-back (bookend mode).

Figure 6 on page 24 shows media converter and end node L/A LED behavior with SML enabled under normal conditions.

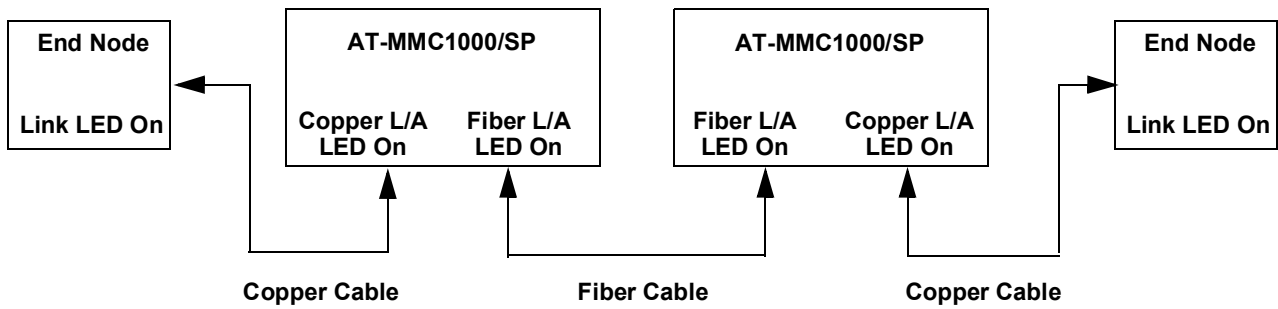

Figure 6. SML in Normal Condition with Two Media Converters

Figure 7 shows media converter and end node L/A LED behavior with SML enabled with a copper connection down between a media converter and an end node.

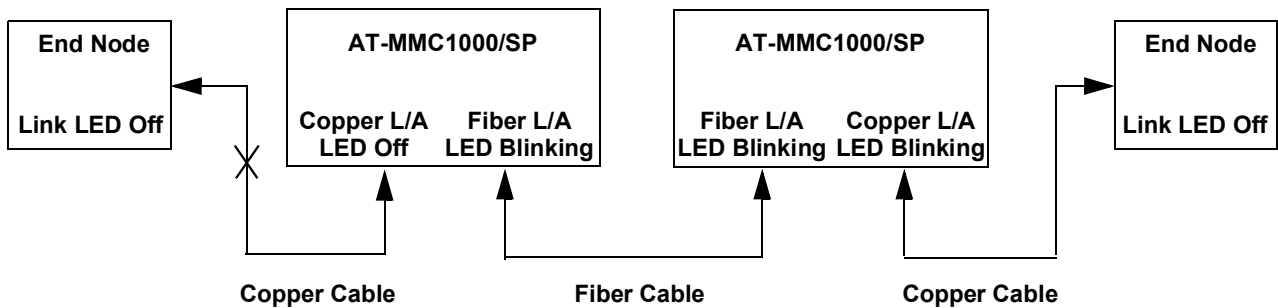

Figure 7. SML with Copper Connection to End Node Down

Figure 8 shows media converter and end node L/A LED behavior with SML enabled with a fiber connection down between two media converters.

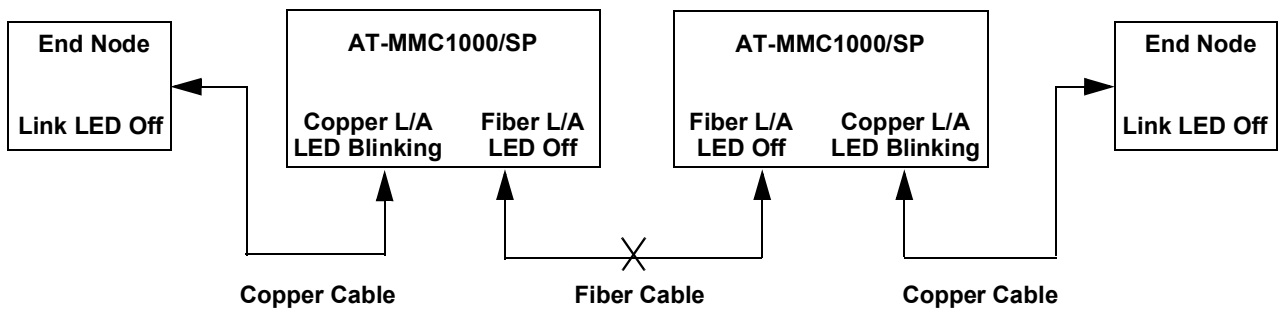

Figure 8. SML with Fiber Connection Between Media Converters Down

Enabling SML

To enable SML on the unit, set the SML ON/OFF DIP switch on the rear panel of the unit to the ON (up) position. See Figure 9.

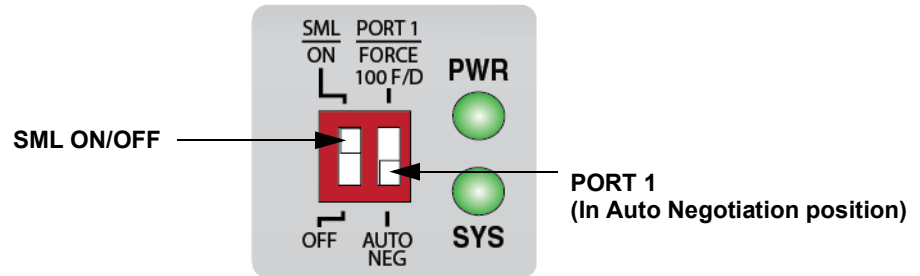

Figure 9. AT-MMC1000/SP Media Converter Rear Panel DIP Switches

Note

For information on the FORCE 100 F/D and AUTO NEG switch, see “Auto-Negotiation or 100 Mbps Full-Duplex Mode” on page 18.

Reset the Media Converter

Reset the media converter by powering OFF then powering ON the unit.

Chapter 2

Installation

This chapter contains the following sections:

- “Reviewing Safety Precautions” on page 28
- “Selecting a Site for the Media Converter” on page 30
- “Planning the Installation” on page 31
- “Unpacking the Media Converter” on page 33
- “Installing the Media Converter” on page 34
- “Installing the SFP Transceiver” on page 35
- “Powering On and Cabling the Media Converter” on page 37

Reviewing Safety Precautions

Review the following safety precautions before you begin to install the chassis or any of its components.

Note

The  indicates that a translation of the safety statement is available in a PDF document titled *Translated Safety Statements* on the Allied Telesis website at www.alliedtelesis.com/support.



Caution

Air vents must not be blocked and must have free access to the room ambient air for cooling.  E6

Note

All Countries: Install product in accordance with local and National Electrical Codes.  E8

Note

The power input must be provided from SELV source only, per IEC60950. Do not connect to a centralized DC battery bank.  E31



Warning

Operating Temperature. This product is designed for a maximum ambient temperature of 50° degrees C.  E57



Caution

Failing to pick up the ferrule tip when you reach the bottom of the cleaning surface can result in static electricity that can damage the fiber-optic cable.  E82



Warning

In a domestic environment this product may cause radio interference in which case the user may be required to take adequate measures.

⌘ E84



Warning

An SFP transceiver can be damaged by static electricity. Be sure to observe all standard electrostatic discharge (ESD) precautions, such as wearing an antistatic wrist strap, to avoid damaging the transceiver. ⌘ E86



Caution

Only use the power adapter supplied with the device. ⌘ E102



Warning

Do not stare into the laser beam. ⌘ L2



Warning

Do not look directly at the fiber-optic cable ends or inspect the cable ends with an optical lens. ⌘ L6



Warning

Laser Safety: EN60825-1. ⌘ L7



Caution

Always install a UL approved Laser Class 1 transceiver module that meets the following specifications. ⌘ E

Power specs for the transceiver module: rated 3.3VDC, maximum 1 watt

Selecting a Site for the Media Converter

Observe the following requirements when choosing a site for your media converter:

- If you are installing the media converter on a table, verify that the table is level and secure.
- The power outlet for the media converter should be located near the unit and should be easily accessible.
- The site should provide for easy access to the ports on the front of the media converter. This will make it easier for you to connect and disconnect cables, as well as view the media converter's LEDs.
- Air flow around the unit and through its vents on the side should not be restricted so that the media converter can maintain adequate cooling.
- Do not place objects on top of the media converter.
- Do not expose the media converter to moisture or water.
- You should use dedicated power circuits or power conditioners to supply reliable electrical power to the network devices.

Planning the Installation

Be sure to observe the following guidelines when planning the installation of your media converter.

- The end node connected to the fiber connector on the SFP module must operate at 100Mbps or 1Gbps.
- The two end-nodes connected to the ports of the media converter must operate with the same duplex mode, either half- or full-duplex. The twisted-pair port on the media converter can operate in either mode with Auto Negotiation enabled.
- The devices connected to the two ports on the media converter can be a network adapter card, repeater, switch, media converter, or router.
- The twisted-pair port has a maximum operating distance of 100 meters (328 feet).
- The maximum operating distance of the AT-MMC1000/SP media converter is dependent on the specific SFP module.
- 100Mbps and 1Gbps SFP modules are supported.
- For a list of supported transceivers, see “Unpacking the Media Converter” on page 33.

Note

You must purchase the SFP transceiver separately.

Table 2 contains the cable specifications for the twisted-pair port.

Table 2. Twisted-Pair Port Cabling Specifications

Speed	Type of Cable
100 Mbps	Standard TIA/EIA 568-A-compliant Category 5 or TIA/EIA 568-B-compliant Enhanced Category 5 (Cat 5e) shielded or unshielded cabling with 100 ohm impedance and a frequency of 100 MHz.
1000 Mbps	Standard TIA/EIA 568-A-compliant Category 5 or TIA/EIA 568-B-compliant Enhanced Category 5 (Cat 5e) shielded or unshielded cabling with 100 ohm impedance and a frequency of 100 MHz.

For speed/duplex interactions between the copper port on the AT-MMC1000/SP media converter and the copper link partner, see Table 3 for allowable speed/duplex combinations.

Table 3. Copper Connection Speed/Duplex Settings and Resulting Speed

Copper Port Speed/Duplex Setting	Copper Link Partner Port Setting			
	Auto Negotiation	100Mbps Force Full Duplex	100Mbps Force Half Duplex	1000Mbps Force Full Duplex*
Auto Negotiation	1000Mbps full duplex connection for Gigabit Link Partners 100Mbps full duplex connection for 100Mbps Link Partners	Duplex mismatch – not supported	100Mbps half duplex connection	1000Mbps full duplex connection
100Mbps Full Duplex	Duplex mismatch – not supported	100Mbps full duplex connection	Duplex mismatch – not supported	No connection
<p>*Although 1000Mbps connections require Auto Negotiation, some switches allow the option of only advertising 1000Mbps speed.</p> <p>Note: The fiber port always runs at 1000Mbps full duplex.</p>				

Unpacking the Media Converter

To unpack the media converter, perform the following procedure:

1. Remove all of the components from the shipping package.

Note

Store the packaging material in a safe location. You must use the original shipping material if you need to return the unit to Allied Telesis.

2. Place the media converter on a level, secure surface.
3. In addition to the media converter, verify that the shipping container includes the power adapter as shown in Figure 10.



Figure 10. Power Adapter in the Shipping Package

Installing the Media Converter

You may install the media converter on a desktop, a wall, or an equipment rack:

- To install the media converter on a desktop, see “Installing the Media Converter on a Desktop,” next.
- To install the media converter on a wall, see “AT-MMCWLMT Kit Installation” on page 47.

Note

To install the media converter on a wall, you must purchase the AT-MMCWLMT kit separately.

- To install the media converter on an equipment rack using the AT-MMCTray6 rack mount kit, see “*Installation Guide: MMCTRAY6*” on Allied Telesis website.

Note

To install the media converter on an equipment rack using the AT-MMCTray6 rack mount kit, you must purchase the kit separately.

- To install the media converter on an equipment rack using the AT-MMCR18 rack mount kit, see “*Installation Guide: AT-MMCR18 Media Converter Rack-Mount Chassis*” on Allied Telesis website.

Note

To install the media converter on an equipment rack using the AT-MMCR18 rack mount kit, you must purchase the kit separately.

Installing the Media Converter on a Desktop

To install the media converter on a desktop, perform the following procedure:

1. Place the media converter on a flat, secure surface (such as a desk or table), leaving ample space around the unit for ventilation.
2. Go to “Installing the SFP Transceiver” on page 35.
3. After installing the SFP transceiver, go to “Powering On and Cabling the Media Converter” on page 37.

Installing the SFP Transceiver

To install an SFP transceiver, perform the following procedure:

Note

The transceiver can be hot-swapped; you do not need to power off the media converter to install a transceiver. However, always remove the cable before removing the transceiver.

Note

You should always install the transceiver before connecting the fiber-optic cable to it.

1. Remove the transceiver from its shipping container and store the packaging material in a safe location.

**Warning**

An SFP transceiver can be damaged by static electricity. Be sure to observe all standard electrostatic discharge (ESD) precautions, such as wearing an antistatic wrist strap, to avoid damaging the transceiver. ⚡ E86

**Caution**

Always install a UL approved Laser Class 1 transceiver module that meets the following specifications. ⚡ E

Power specs for the transceiver module: rated 3.3VDC, maximum 1 watt

2. Position the SFP transceiver with the label facing up.
3. Slide the transceiver into the SFP slot until it clicks into place. See Figure 11 on page 36.

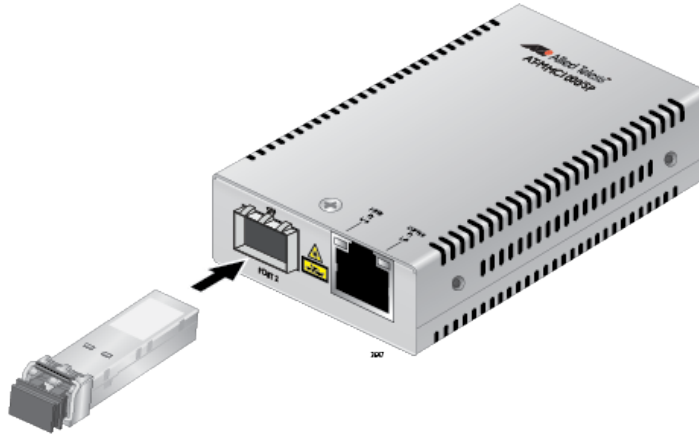

Figure 11. Inserting the SFP

4. Verify that the handle on the transceiver is in the upright position, as shown in Figure 12. This secures the transceiver and prevents it from being dislodged from the slot.

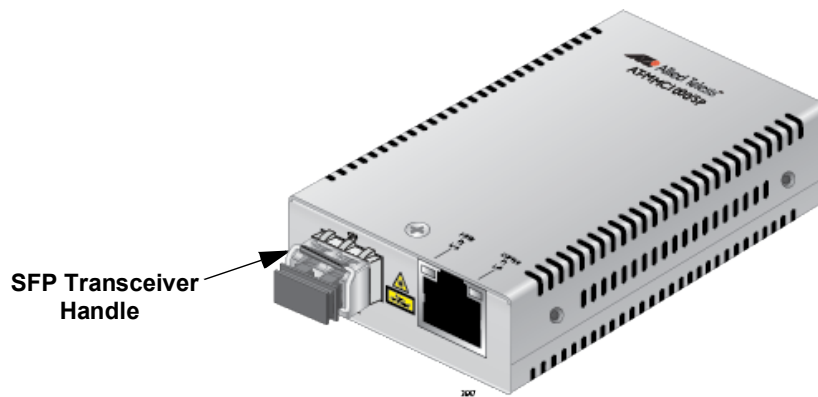

Figure 12. Positioning the SFP Handle in the Upright Position

Note

SFP transceivers are dust-sensitive. Always keep the plug in the optical bores when a fiber-optic cable is not installed, or when storing the SFP. When you do remove the plug, keep it for future use.

Note

Unnecessary removal and insertion of an SFP can lead to premature failure.

For information on the cable specifications of the SFP, consult the documentation shipped with the SFP.

5. Go to “Powering On and Cabling the Media Converter” on page 37.

Powering On and Cabling the Media Converter

Cabling Guidelines

Observe the following guidelines when connecting twisted-pair and fiber-optic cables to the ports on the media converter:

- The connector on the cable should fit snugly into the port on the media converter. The tab on the connector should lock the connector into place.
- Because the twisted-pair port has Auto MDI/MDI-X, you may use straight-through twisted-pair cable to connect any type of network device to that port.
- For the fiber optic cables, refer to the cable manufacturer specification for the minimum bend radius.

Applying Power and Connecting the Network Cables

To apply power to the media converter and connect the network cables, perform the following steps:

1. Plug the DC of the external power adapter to the power receptacle connector labeled 12VDC on the back panel of the media converter and turn the cord clockwise one-quarter turn to lock, as shown in Figure 13.

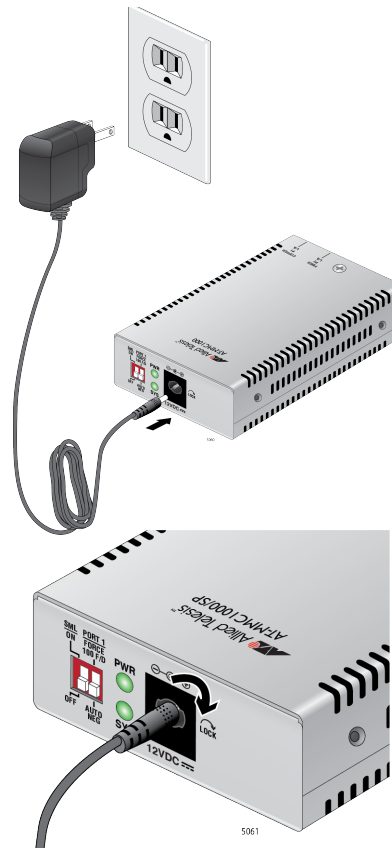

Figure 13. Connecting 12VDC Powered Unit

2. Plug the power adapter to a power outlet. Refer to “Power Specifications” on page 44 for power requirements.
3. Verify that the PWR LED is lit green. If the PWR LED is off, refer to “Troubleshooting” on page 39.
4. Verify that the SYS LED is lit green. If the SYS LED is off, refer to “Troubleshooting” on page 39.
5. Remove the dust cover from the fiber-optic connector and connect the cable to the fiber-optic port.

Connect the red TX connector on the fiber-optic cable to the transmitter port on the SFP module and connect the other connector to the receiver port on the end node. Then connect the black RX connector on the fiber-optic cable to the receiver port on the SFP module and connect the other connector to the transmitter port on the end node.

6. Connect the twisted-pair cable to the twisted-pair port.
For speed/duplex interactions between the copper port and the copper link partner, refer to Table 3 on page 32 for allowable speed/duplex combinations.
7. Power on the end nodes.

The media converter is now ready for use.

Chapter 3

Troubleshooting

This chapter contains information on how to troubleshoot the media converter if a problem occurs.

Note

For further assistance, please contact Allied Telesis Technical Support at www.alliedtelesis.com/support.

Problem 1: The POWER LED on the media converter is off.

Solutions: The unit is not receiving power. Try the following:

- Verify that the power cord is securely connected to the power source and to the DC connector on the back panel of the media converter.
- Verify that the power outlet has power by connecting another device to it.
- Try using another power adapter of the same type that came with your media converter.
- Verify that the voltage from the power source is within the required levels for your region.

Problem 2: The SYS LED on the media converter is off.

Solution: An internal component on the unit is damaged or not working properly. Try power cycling the unit. If power cycling does not clear the fault, return the unit to Allied Telesis.

Problem 3: The SYS LED on the media converter is blinking slowly.

Solutions: An error is present on the unit. Try power cycling the unit.

A transmit fault may be occurring on the SFP module. The media converter will try to clear this error, but if the error persists, try the following:

- Remove and re-seat the SFP module.
- Try a different SFP module.
- Verify the SFP module is the correct type for your application.

Problem 4: The twisted-pair port on the media converter is connected to an end node, but the port's COPPER P1 L/A LED is off.

Solutions: The port is unable to establish a link to an end node. Try the following:

- Verify that the end node connected to the twisted-pair port is powered on and is operating properly.
- Verify that the twisted-pair cable is securely connected to the port on the media converter channel and to the port on the remote end-node.
- Verify that the port is connected to the correct twisted-pair cable. This is to eliminate the possibility that the port is connected to the wrong end-node, such as a powered-off device.
- Try connecting another end node to the twisted-pair port with a different cable. If the twisted-pair port is able to establish a link, then the problem is with the cable or the other end-node.
- Verify that the twisted-pair cable does not exceed 100 meters (328 feet).
- Verify that the end node connected to the media converter is operating at the same speed.
- Verify that you are using the appropriate category of twisted-pair cable: Category 5 or Category 5E.

Note

A 1000Base connection may require 5 to 10 seconds to establish a link.

Problem 5: The FIBER P2 L/A LED for the fiber-optic port is off.

Solutions: The fiber-optic port on the transceiver is unable to establish a link to an end node. Try the following:

- Verify that the end node connected to the fiber-optic port is operating properly.
- Verify that the fiber-optic cable is securely connected to the port on the media converter channel and to the port on the remote end-node.
- Verify that the end node connected to the media converter is operating at the same speed.
- Check that the SFP module is fully inserted in the slot.

- Verify that the operating specifications and wave lengths of the fiber-optic port on the SFP transceiver and the remote end-node are compatible.
- Verify that the correct type of fiber-optic cabling is being used.
- Verify that the wavelength between the media converter and end node matches, and the media converter fiber port is connected to a multi-mode (not single-mode) port on the end node.
- Verify that the port is connected to the correct fiber-optic cable. This is to eliminate the possibility that the port is connected to the wrong remote end-node, such as a powered-off device.
- Try connecting another end node to the fiber-optic port using a different cable. If the port is able to establish a link, then the problem is with the cable or with the other end node.
- If the remote end-node is a management device, use its management firmware to determine whether its port is enabled.
- Test the attenuation on the fiber-optic cable with a fiber-optic tester to determine whether the optical signal is too weak (sensitivity) or too strong (maximum input power).

Problem 6: Network performance between the twisted-pair port on the media converter and an end node is slow.

Solution: There might be a duplex mode mismatch between the port and the end node. This occurs when a twisted-pair port using Auto Negotiation is connected to a device with a fixed duplex mode of full duplex. If this is the cause of the problem, adjust the duplex mode of the port on the end node or on the media converter so that both ports are using the same duplex mode.

Appendix A

Technical Specifications

Below are the technical specifications for the media converters. The specification categories are as follows:

- “Physical Specifications”
- “Environmental Specifications”
- “Power Specifications” on page 44
- “RJ45 Connector and Port Pinouts” on page 44

Physical Specifications

Table 4. Physical Specifications

Dimensions W x D x H	5.5 cm x 10.2 cm x 2.1 cm (2.2 in x 4 in x 0.8 in)
Weight	168.4 g (5.9 oz)

Environmental Specifications

Table 5. Environmental Specifications

Operating Temperature	0° C to 50° C (32° F to 122° F)
Storage Temperature	-30° C to 70° C (-22° F to 158° F)
Operating Humidity	5% to 95% non-condensing
Storage Humidity	5% to 95% non-condensing
Operating Altitude Range	Up to 3,000 m (9,843 ft)

Power Specifications

The following specifications apply to the DC power connector on the media converter.

Table 6. Power Specifications

Input supply voltage	12 VDC
Input current	0.7 A

RJ45 Connector and Port Pinouts

Figure 14 illustrates the pin layout for the RJ45 connector and port.

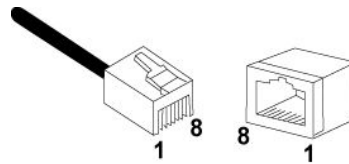

Figure 14. RJ45 Connector and Port Pin Layout

Table 7 lists the pin signals when a port is operating in the MDI configuration at 10 or 100 Mbps.

Table 7. MDI Pin Signals (10 or 100 Mbps)

Pin	Signal
1	TX+
2	TX-
3	RX+
6	RX-

Table 8 lists the pin signals when a port is operating in the MDI-X configuration at 10 or 100 Mbps.

Table 8. MDI-X Pin Signals (10 or 100 Mbps)

Pin	Signal
1	RX+
2	RX-
3	TX+
6	TX-

Table 9 lists the pin signals when a port is operating at 1000 Mbps.

Table 9. Pin Signals (1000 Mbps)

Pin	Pair	Signal
1	1	TX and RX+
2	1	TX and RX-
3	2	TX and RX+
4	3	TX and RX+
5	3	TX and RX-
6	2	TX and RX-
7	4	TX and RX+
8	4	TX and RX-

Appendix B



AT-MMCWLMT Kit Installation

Before installing an MMC media converter on a wall, you must have an AT-MMCWLMT Kit that is provided separately.

When installing a media converter on a wood wall, you must provide four 4x32mm wood screws per media converter in addition to the AT-MMCWLMT Kit.

1. Verify that the AT-MMCWLMT Kit contains the items shown in Table 10.

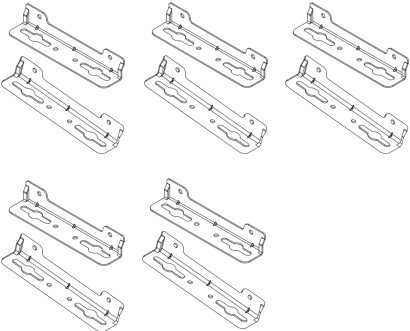
Table 10 AT-MMCR WLMT Kit Contents

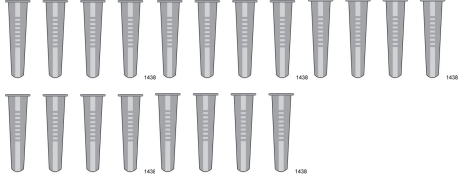
Description	Illustration
5 Sets of Wall Mounting Brackets	
20 Bracket Screws	
20 Self-tapping Screws (3.5x20mm)	
20 Plastic Anchors	

2. Select a wall location for the unit.
3. Place the unit on a table.

4. Orient the brackets against the sides of the unit, as shown in step 15, and secure them to the unit with the four of the brackets screws included.

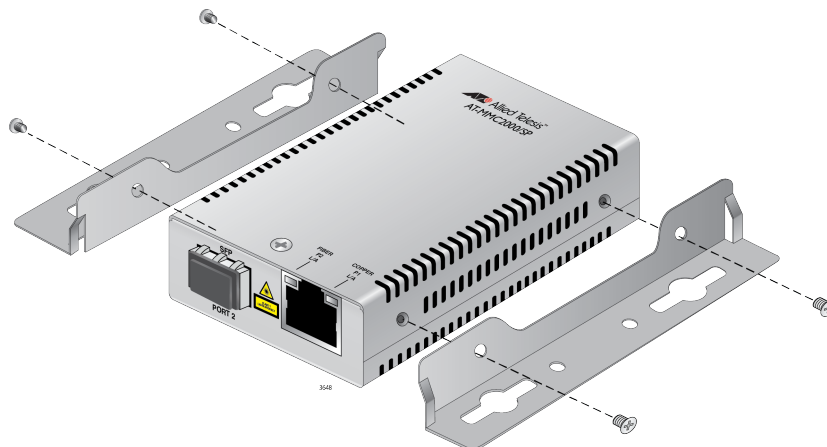

Figure 15. Attaching the Brackets to the Media Converter

5. Print out the template in Figure 16.

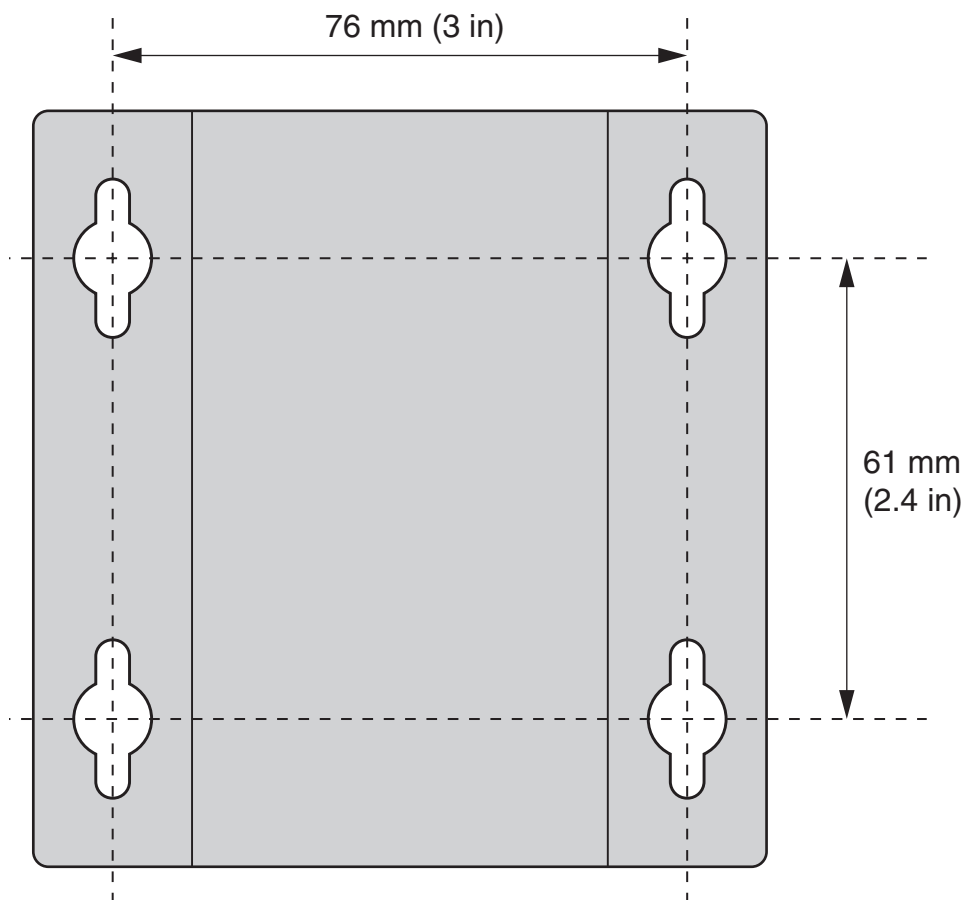

Figure 16. Wall-mount Template

6. Use scotch tape to attach the template on the wall.
7. Pre-drill four 3/16" (5mm) holes at the locations on the templates as shown in Figure 17.

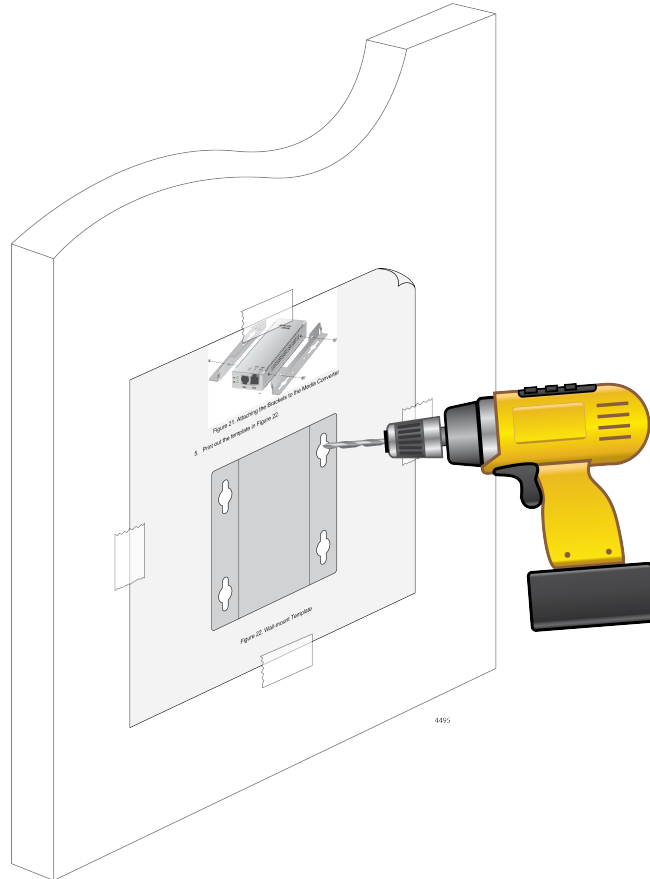

Figure 17. Placing the Template on the Wall

8. Remove the template from the wall.
9. If you are installing the media converter on a concrete wall, install four plastic anchors included with AT-MMCWLMT Kit into the concrete wall, at the holes you drilled in the previous step.

If you are installing the media converter on a wood wall, skip this step and go to step 10.

10. Secure the media converter unit to the wall using four screws as shown in Figure 18 on page 50.
 - On a concrete wall: use the 3.5x20mm self-tapping screws included in the kit.
 - On a wood wall: use the 4x32mm wood screws (*not* included).

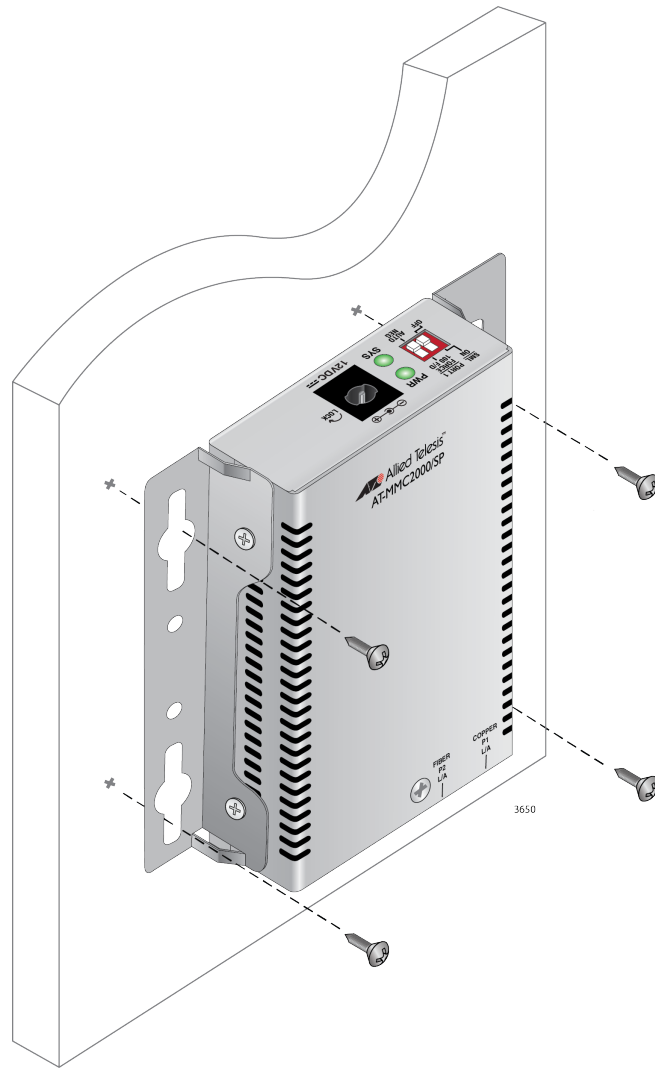

Figure 18. Securing the Media Converter to the Wall